

# INFRARED DETECTORS AND MODULES – CONFIGURABLE LINE

VIGO offers various types of infrared detectors based on Mercury Cadmium Telluride, Indium Arsenide and Indium Arsenide Antimonide featuring different parameters.

## Main features

- › Optimized at any wavelength from 2 – 14  $\mu\text{m}$  spectral range
- › With or without immersion technology
- › Uncooled or thermoelectrically cooled
- › Different sizes of active/optical area
- › Different packages
- › Different infrared windows
- › Different acceptance angle
- › Wide range of dedicated preamplifiers and accessories

Distributor



**amSTECHNOLOGIES**

where technologies meet solutions

info@amstechnologies.com  
www.amstechnologies-webshop.com

**Contact us** 

## How to choose a preamplifier?

Infrared detection module integrates infrared photodetector and preamplifier in a common package. The integration makes detectors less vulnerable to:

- over-bias,
- electrostatic discharges,
- electromagnetic interferences,
- other environmental exposures.

Additional advantages of integration are: improved high-frequency performance, output signal standardization, miniaturization and cost reduction. The broad line of transimpedance preamplifiers is especially designed for integration with VIGO IR detectors.

Main feature	Phoyo	Preamplifier type	Detector type	Low cut-off frequency $f_{lc}$ , Hz	High cut-off frequency $f_{hc}$ , Hz	Transimpedance $K_t$ , V/A	Radiator / fan	TEC controller	Mounting hole
All-in-one		AIP	TE cooled PC/ PCI TE cooled PV/PVI TE cooled PVA/PVIA TE cooled PVM/PVMI	DC, 10, 100, 1k, 10k	100k, 1M, 10M, 100M, 250M	up to 200k (fixed)	on board	on board	M4
Programmable		PIP	TE cooled PC/ PCI TE cooled PV/PVI TE cooled PVA/PVIA TE cooled PVM/PVMI	DC/10 (digitally adjustable)	150k/1.5M/20M 1.5M/15M/200M (digitally adjustable)	2.5k – 150k 0.5k – 30k (digitally adjustable)	on board	PTCC-01 obligatory	M4
Standard		MIP	TE cooled PC/ PCI TE cooled PV/PVI TE cooled PVA/PVIA TE cooled PVM/PVMI	DC, 10, 100, 1k, 10k	100k, 1M, 10M, 100M, 250M	up to 200k (fixed)	on board	PTCC-01 necessary	M4
Fast		FIP	TE cooled PV/PVI	1k, 10k	1G	up to 8.5k (fixed)	on board	PTCC-01 necessary	M4
Small		SIP-TO8	TE cooled PC/ PCI TE cooled PV/PVI TE cooled PVA/PVIA TE cooled PVM/PVMI	DC, 10, 100, 1k, 10k	100k, 1M, 10M, 100M, 250M	up to 100k (tunable)	external heatsink necessary	PTCC-01 necessary	none
Small		SIP-TO39	TE cooled PC/ PCI TE cooled PV/PVI TE cooled PVA/PVIA TE cooled PVM/PVMI	DC, 10, 100, 1k, 10k	100k, 1M, 10M, 100M, 250M	up to 100k (tunable)	not necessary	not necessary	none

To obtain the most optimal parameters of integrated module each preamplifier is individually matched to the selected detector. The parameters of integrated set will be known after final evaluation (matching, adjustment and final tests).

If you need any assistance in selecting VIGO product appropriate for your application, please contact VIGO Technical Support Team: techsupport@vigo.com.pl

# AIP series

**AIP** is a new generation of transimpedance, AC or DC coupled preamplifiers. It is designed to operate with either biased or non-biased VIGO detectors. AIP is „all-in-one” device – a preamplifier is integrated with a fan and a thermoelectric cooler controller in a compact housing. It is very convenient and user-friendly device, thus can be easily used in a variety of applications.

## Specification ( $T_a = 20^\circ\text{C}$ )

Parameter	Typical value	Conditions, remarks
Low cut-off frequency $f_{lo}$ , Hz	DC, 10, 100, 1k, 10k	
High cut-off frequency $f_{hi}$ , Hz	100k, 1M, 10M, 100M, 250M	
Transimpedance $K_p$ , V/A	up to 200k	fixed
Output impedance $R_{out}$ , $\Omega$	50	
Output voltage swing $V_{out}$ , V	$\pm 2 \pm 1$	$f_{hi} \leq 1 \text{ MHz}, R_L = 1 \text{ M}\Omega$ $f_{hi} > 1 \text{ MHz}, R_L = 50 \Omega$ )
Output voltage offset $V_{off}$ , mV	max $\pm 20^{**}$	
Power supply voltage $V_{sup}$ , V	+5 +12	with 2TE and 3TE cooled detectors with 4TE cooled detectors
Power supply current $I_{sup}$ , mA	max $\pm 50$	
Ambient operating temperature $T_a$ , $^\circ\text{C}$	10 to 30	
Signal output socket	SMA	RF output
DC output socket	SMA	DC monitor
Supply socket	DC 2.1/5.5 DC 2.5/5.5	$V_{sup} = +12 \text{ V}$ $V_{sup} = +5 \text{ V}$
Mounting hole	M4	
Fan	yes	

<sup>\*)</sup>  $R_L$  – load resistance

<sup>\*\*)</sup> Measured with equivalent resistor at the input instead of the detector, it is to avoid the environmental thermal radiation impact.



## Features

- › Integrated TEC controller and fan
- › Frequency bandwidth up to 250 MHz
- › Single power supply
- › DC monitor
- › Optimised for effective heat dissipation
- › Compatible with optical accessories
- › Cost effective OEM version available
- › Universal and flexible

## Types of VIGO detectors that can be integrated with AIP preamplifier

- › **Photoconductive**  
PC-2TE, PC-3TE, PC-4TE
- › **Photoconductive optically immersed**  
PCI-2TE, PCI-3TE, PCI-4TE
- › **Photovoltaic**  
PV-2TE, PVA-2TE, PV-3TE, PV-4TE
- › **Photovoltaic optically immersed**  
PVI-2TE, PVIA-2TE, PVI-3TE, PVI-4TE
- › **Photovoltaic multiple junction**  
PVM-2TE
- › **Photovoltaic multiple junction optically immersed**  
PVMI-2TE, PVMI-3TE, PVMI-4TE

## Code description

Type	$f_{lo}$ , Hz	$f_{hi}$ , Hz	Version
<b>AIP</b>	DC	100	S <sup>*)</sup> (with package)
	10	1M	
	100	10M	
	1k	100M	
	10k	250M	

<sup>\*)</sup> OEM version available upon request.

## Included accessories

- › 2x **SMA-BNC** cables + **AC adaptor**

## Dedicated accessories

- › **OTA** optical threaded adapter
- › **DRB-2** base mounting system

## Mechanical layout, mm

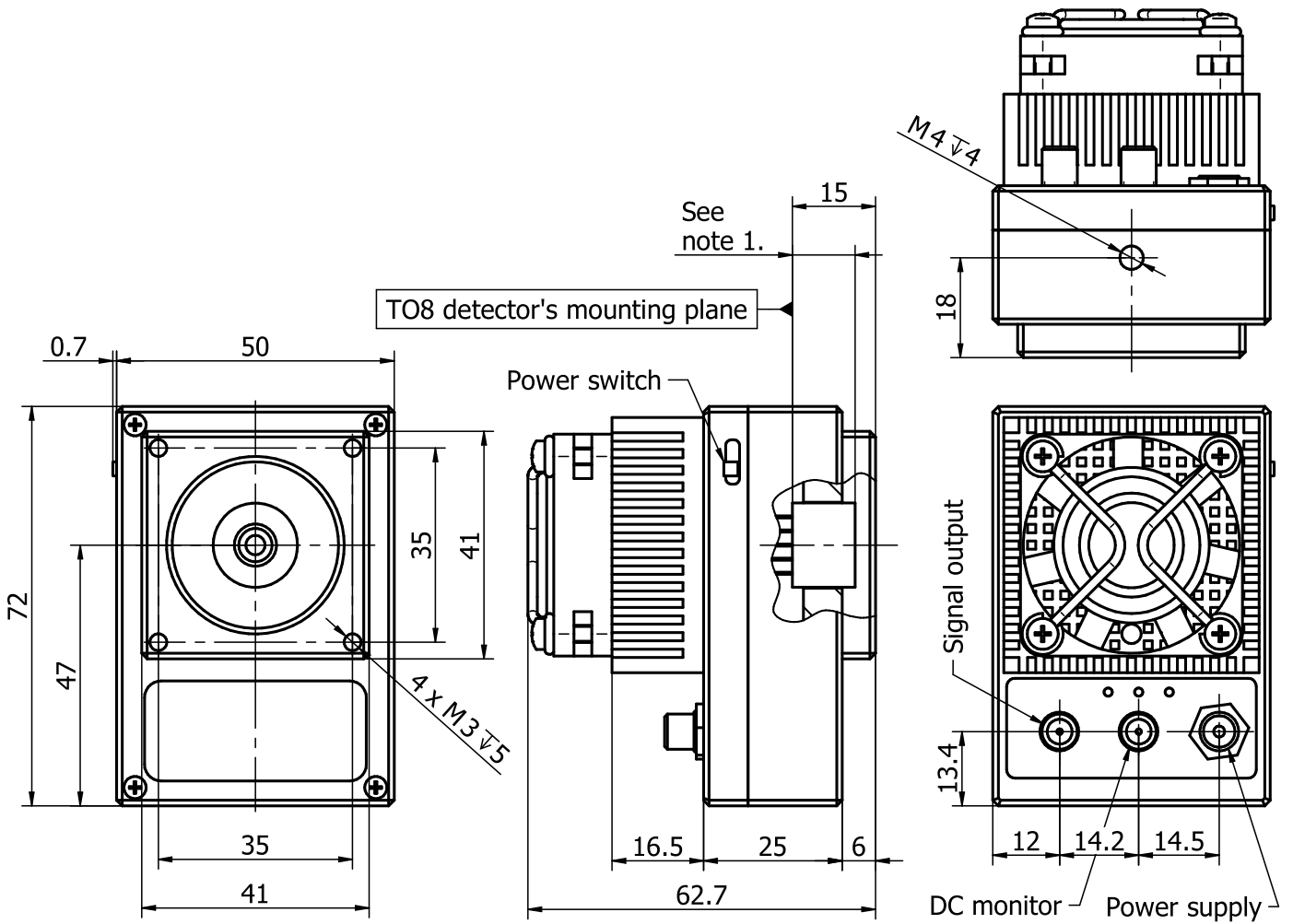

Notes:

1. TO8 detector dimensions in the "TO8 technical drawing".

# PIP series

**PIP** is a series of programmable “smart” preamplifiers. Due to the modern internal configuration, it offers extreme flexibility combined with superior signal parameters and high reliability. Built-in voltage monitor allows to check and optimize the working conditions (supply voltages, detector bias voltage, first and last stage output voltage offset etc.).

There is also possible to change the gain, coupling (AC/DC), optimize the first stage transimpedance and manually or automatically suppress the voltage offset. Optimized parameters are stored into the internal EEPROM memory and automatically loaded after the power is on. Reset to default settings is available at any time. For detection module safety detector bias adjusting is blocked by default. User can request to enable this option while ordering.

For proper operation PTCC-01 TEC controller is required.

## Specification ( $T_a = 20^\circ\text{C}$ )

Parameter	Typical value	Conditions, remarks
Low cut-off frequency $f_{lo}$ , Hz	DC/10	user configurable by software
High cut-off frequency $f_{hi}$ , Hz	150k/1.5M/20M 1.5M/15M/200M	user configurable by software
Transimpedance $K_v$ , V/A	"2.5k – 150k 0.5k – 30k"	"digitally adjustable first stage transimpedance = 1 kΩ first stage transimpedance = 5 kΩ"
Output impedance $R_{out}$ , Ω	50	
Output voltage swing $V_{out}$ , V	±1	$R_L = 50 \Omega$ <sup>1)</sup>
Output voltage offset $V_{off}$ , mV	max ±20 <sup>2)</sup>	
Ambient operating temperature $T_a$ , °C	10 to 30	
Signal output socket	SMA	
Power supply and TEC control socket	LEMO (female)	ECG.0B.309.CLN
Mounting hole	M4	
Fan	yes	

<sup>1)</sup>  $R_L$  – load resistance

<sup>2)</sup> Measured with equivalent resistor at the input instead of the detector, it is to avoid the environmental thermal radiation impact.



## Parameters configurable by the user

- Output voltage offset
- Gain (in 40 dB range)
- Bandwidth
  - 150 kHz/1.5 MHz/20 MHz
  - 1.5 MHz/15 MHz/100 MHz
- Coupling AC/DC
- Detector’s parameters (temperature, reverse bias etc.)

## Types of VIGO detectors that can be integrated with PIP preamplifier

- **Photoconductive**  
PC-2TE, PC-3TE, PC-4TE
- **Photoconductive optically immersed**  
PCI-2TE, PCI-3TE, PCI-4TE
- **Photovoltaic**  
PV-2TE, PVA-2TE, PV-3TE, PV-4TE
- **Photovoltaic optically immersed**  
PVI-2TE, PVIA-2TE, PVI-3TE, PVI-4TE
- **Photovoltaic multiple junction**  
PVM-2TE
- **Photovoltaic multiple junction optically immersed**  
PVMI-2TE, PVMI-3TE, PVMI-4TE

## Included accessories

- **SMA-BNC, LEMO-DB9** cables

## Dedicated accessories

- **PTCC-01-BAS** TEC controller + **USB: TypeA-MicroB** cable + **AC adaptor**
- **PTCC-01-ADV** TEC controller + **USB: TypeA-MicroB** cable + **AC adaptor**
- **PTCC-01-OEM** TEC controller + **USB: TypeA-MicroB, KK2-POWER** cables
- **OTA** optical threaded adapter
- **DRB-2** base mounting system

## Code description

Type	$f_{lo}$	$f_{hi}$
<b>PIP</b>	<b>UC</b> <sup>1)</sup> (DC/10 Hz)	<b>LS</b> <sup>1)</sup> (150 kHz/1.5 MHz/20 MHz) <b>HS</b> <sup>1)</sup> (1.5 MHz/15 MHz/200 MHz)

<sup>1)</sup> User configurable by software.

## Power supply and TEC control socket LEMO (female) ECG.0B.309.CLN

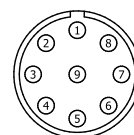

Function	Symbol	Pin number
Fan and programmable preamp internal logic auxiliary supply	FAN+	1
Thermistor output (2)	TH2	2
TEC supply input (-)	TEC-	3
Power supply input (-)	- $V_{sup}$	4
Ground	GND	5
Power supply input (+)	+ $V_{sup}$	6
TEC supply input (+)	TEC+	7
Thermistor output (1)	TH1	8
Bidirectional data pin	DATA	9

### Mechanical layout, mm

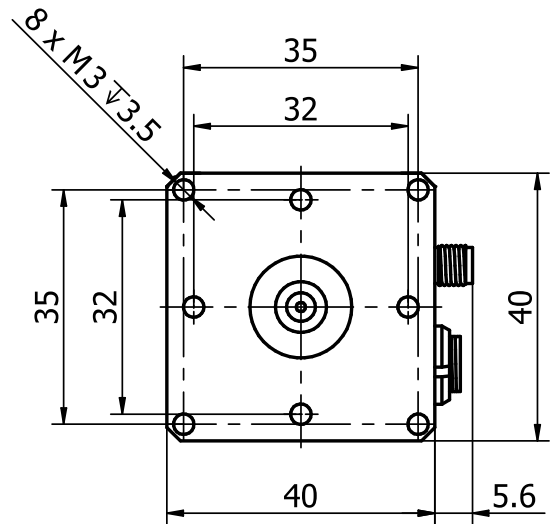
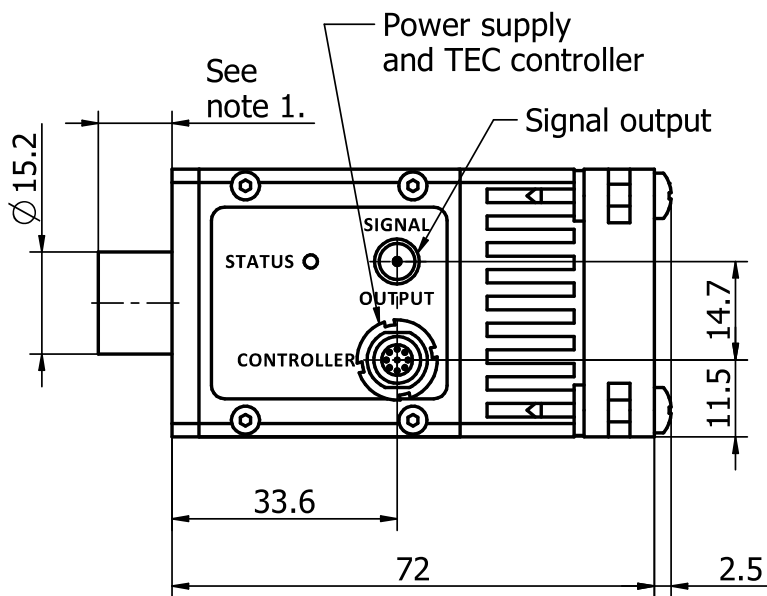
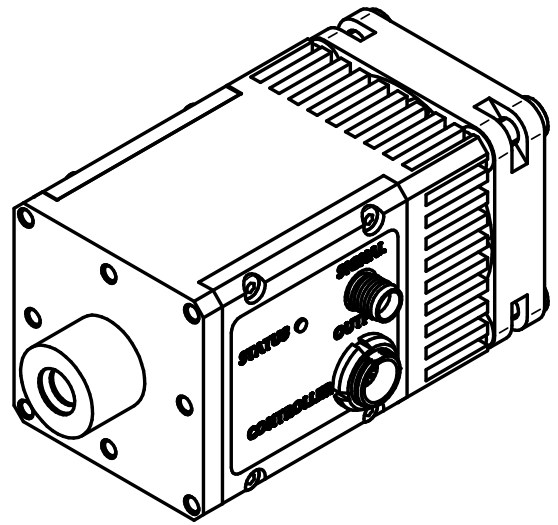
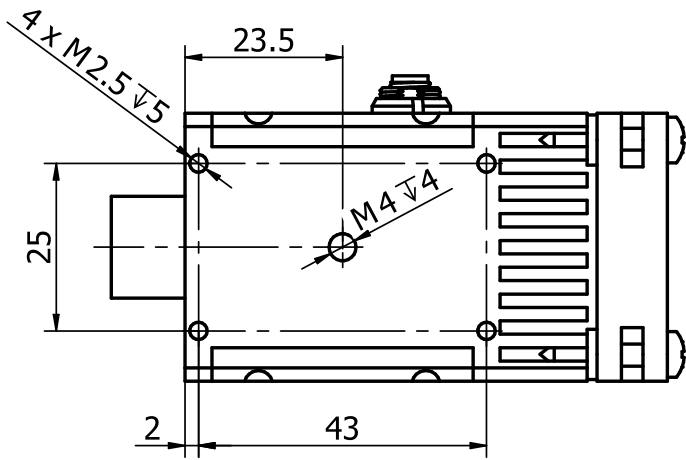

Notes:

- TO8 detector dimensions in the "TO8 technical drawing".

# MIP series

**MIP** is a series of medium-size transimpedance, DC or AC coupled preamplifiers, intended to operate with either biased or non-biased VIGO detectors. MIP is equipped with a fan and does not require any additional external heatsink. It is one of the most user-friendly preamplifier which surely facilitate work.

## Specification ( $T_a = 20^\circ\text{C}$ )

Parameter	Typical value	Conditions, remarks
Low cut-off frequency $f_{lo}$ , Hz	DC, 10, 100, 1k, 10k	
High cut-off frequency $f_{hi}$ , Hz	100k, 1M, 10M, 100M, 250M	
Transimpedance $K_v$ , V/A	up to 200k	fixed
Output impedance $R_{out}$ , $\Omega$	50	
Output voltage swing $V_{out}$ , V	$\pm 10 \pm 1$	$f_{hi} \leq 1 \text{ MHz}, R_L = 1 \text{ M}\Omega$ $f_{hi} > 1 \text{ MHz}, R_L = 50 \Omega$ )
Output voltage offset $V_{off}$ , mV	max $\pm 20$ <sup>*)</sup>	
Power supply voltage $V_{sup}$ , V	$\pm 15 \pm 9$	$f_{hi} \leq 1 \text{ MHz}$ $f_{hi} > 1 \text{ MHz}$
Power supply current $I_{sup}$ , mA	max $\pm 50$	
Ambient operating temperature $T_a$ , $^\circ\text{C}$	10 to 30	
Signal output socket	SMA	
Power supply and TEC control socket	LEMO (female)	ECG.0B.309.CLN
Mounting hole	M4	
Fan	yes	

<sup>\*)</sup>  $R_L$  – load resistance

<sup>\*\*)</sup> Measured with equivalent resistor at the input instead of the detector, it is to avoid the environmental thermal radiation impact.



## Features

- › Frequency bandwidth up to 250 MHz
- › Integrated fan
- › Compatible with optical accessories

## Types of VIGO detectors that can be integrated with MIP preamplifier

- › **Photoconductive**  
PC-2TE, PC-3TE, PC-4TE
- › **Photoconductive optically immersed**  
PCI-2TE, PCI-3TE, PCI-4TE
- › **Photovoltaic**  
PV-2TE, PVA-2TE, PV-3TE, PV-4TE
- › **Photovoltaic optically immersed**  
PVI-2TE, PVIA-2TE, PVI-3TE, PVI-4TE
- › **Photovoltaic multiple junction**  
PVM-2TE
- › **Photovoltaic multiple junction optically immersed**  
PVMI-2TE, PVMI-3TE, PVMI-4TE

## Included accessories

- › **SMA-BNC, LEMO-DB9** cables

## Dedicated accessories

- › **PTCC-01-BAS** TEC controller + **USB: TypeA-MicroB cable + AC adaptor**
- › **PTCC-01-ADV** TEC controller + **USB: TypeA-MicroB cable + AC adaptor**
- › **PTCC-01-OEM** TEC controller + **USB: TypeA-MicroB, KK2-POWER** cables
- › **OTA** optical threaded adapter
- › **DRB-2** base mounting system

## Code description

Type	$f_{lo}$ , Hz	$f_{hi}$ , Hz
<b>MIP</b>	<b>DC</b>	<b>100</b>
	<b>10</b>	<b>1M</b>
	<b>100</b>	<b>10M</b>
	<b>1k</b>	<b>100M</b>
	<b>10</b>	<b>250M</b>

## Power supply and TEC control socket LEMO (female) ECG.0B.309.CLN

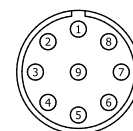

Function	Symbol	Pin number
Fan (+)	FAN+	1
Thermistor output (2)	TH2	2
TEC supply input (-)	TEC-	3
Power supply input (-)	$-V_{sup}$	4
Ground	GND	5
Power supply input (+)	$+V_{sup}$	6
TEC supply input (+)	TEC+	7
Thermistor output (1)	TH1	8
Data pin	DATA	9

### Mechanical layout, mm

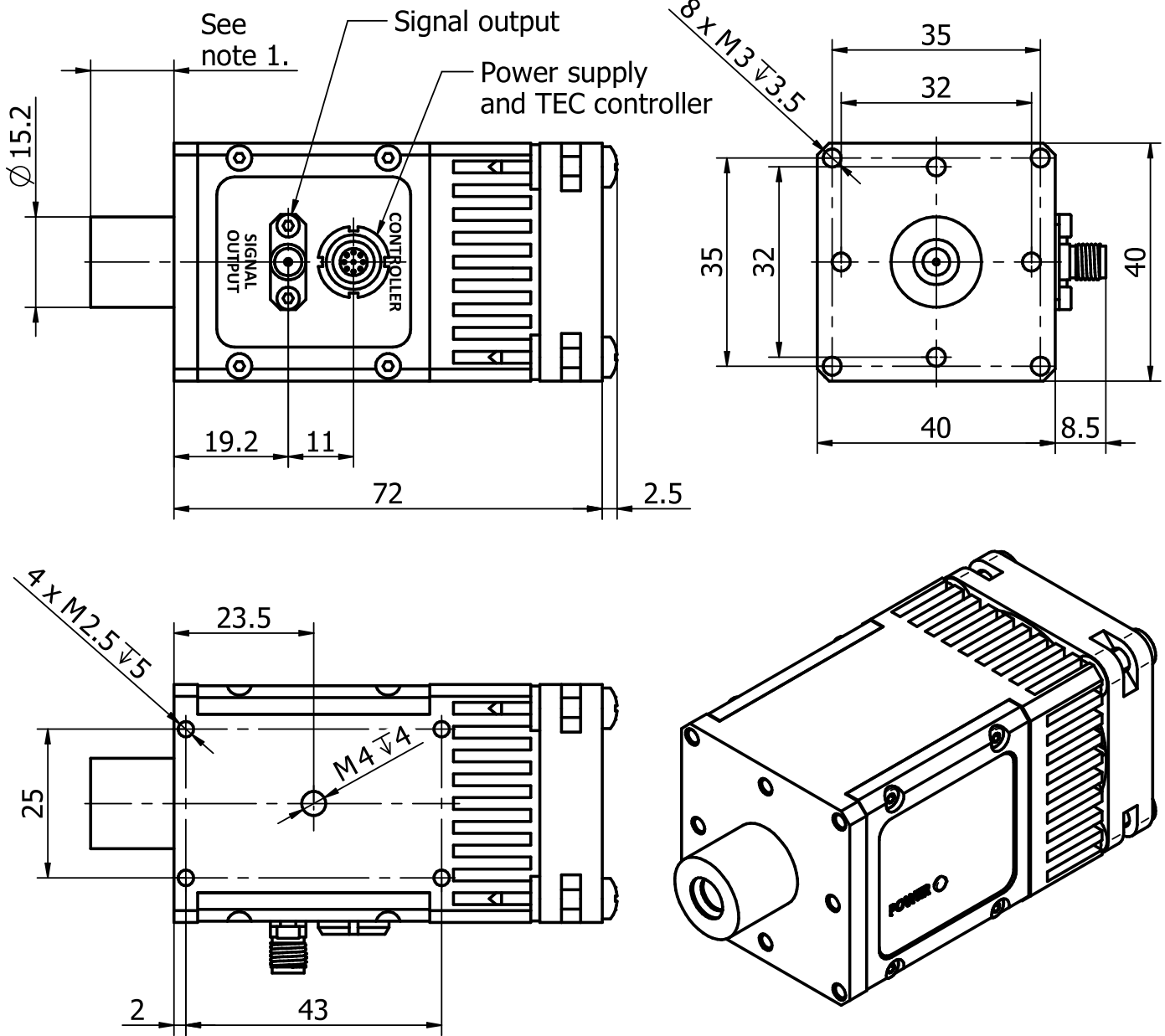

Notes:

1. TO8 detector dimensions in the "TO8 technical drawing".





**amSTECHNOLOGIES**  
where technologies meet solutions

info@amstechnologies.com  
www.amstechnologies-webshop.com



# FIP series

**FIP** is a series of high speed, transimpedance, AC coupled preamplifiers, intended to operate with biased TE cooled VIGO detectors. Fast preamplifier enables precise I-V conversion, detector biasing up to 800 mV and simultaneously maintains compact size and keeps current noise low. FIP is equipped with a fan and does not require additional heat dissipation. It is suitable for applications requiring wide frequency bandwidth. Additional DC output is available as an option.

## Specification ( $T_a = 20^\circ\text{C}$ )

Parameter	Typical value	Conditions, remarks
Low cut-off frequency $f_{lo}$ , Hz	1k, 10k	
High cut-off frequency $f_{hi}$ , Hz	1G	
Transimpedance $K_v$ , V/A	up to 8.5k	fixed
Output impedance $R_{out}$ , $\Omega$	50	
Output voltage swing $V_{out}$ , V	$\pm 1$	$R_L = 50 \Omega^*)$
Power supply voltage $V_{sup}$ , V	+12 / -5	
Power supply current $I_{sup}$ , mA	100 -50	
Ambient operating temperature $T_{op}$ , $^\circ\text{C}$	10 to 30	
Signal output socket	SMA	RF output
DC monitor socket	SMA	option
Power supply and TEC control socket	LEMO (female)	ECG.0B.309.CLN
Mounting hole	M4	
Fan	yes	

<sup>\*)</sup>  $R_L$  – load resistance



## Features

- › Wide frequency bandwidth up to 1 GHz
- › Integrated fan
- › DC monitor as an option

## Types of VIGO detectors that can be integrated with FIP preamplifier

- › **Photovoltaic**  
PV-2TE, PV-3TE, PV-4TE
- › **Photovoltaic optically immersed**  
PVI-2TE, PVI-3TE, PVI-4TE

## Code description

Type	$f_{lo}$ , Hz	$f_{hi}$ , Hz	Version
<b>AIP</b>	1k 10k	1G	<b>D</b> (with DC monitor) <b>ND</b> (without DC monitor)

## Power supply and TEC control socket LEMO (female) ECG.0B.309.CLN

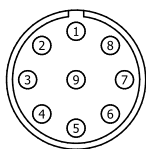

Function	Symbol	Pin number
Fan (+)	FAN+	1
Thermistor output (2)	TH2	2
TEC supply input (-)	TEC-	3
Power supply input (-)	$-V_{sup}$	4
Ground	GND	5
Power supply input (+)	$+V_{sup}$	6
TEC supply input (+)	TEC+	7
Thermistor output (1)	TH1	8
Data pin	DATA	9

## Included accessories

- › **SMA-BNC<sup>\*)</sup>, LEMO-DB9** cables

<sup>\*)</sup> Additional SMA-BNC cable for FIP-xx-xx-D version.

## Dedicated accessories

- › **PTCC-01-BAS** TEC controller + **USB: TypeA-MicroB** cable + **AC adaptor**
- › **PTCC-01-ADV** TEC controller + **USB: TypeA-MicroB** cable + **AC adaptor**
- › **PTCC-01-OEM** TEC controller + **USB: TypeA-MicroB, KK2-POWER** cables
- › **DRB-2** base mounting system

### Mechanical layout, mm

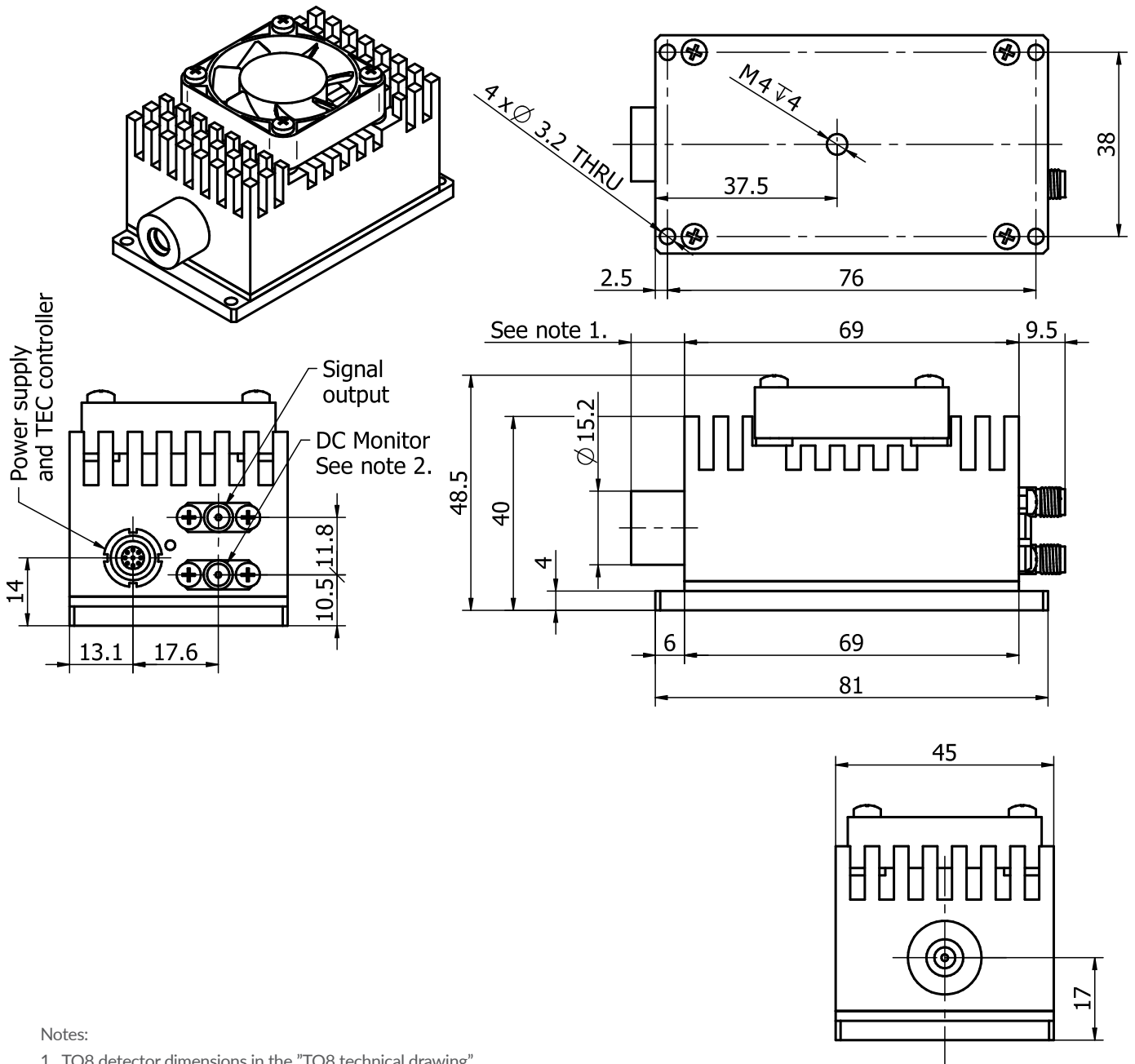

Notes:

1. TO8 detector dimensions in the "TO8 technical drawing".
2. Only for FIP-xx-xx-D version.

# SIP series

**SIP** is a series of ultra-small transimpedance, AC or DC coupled preamplifiers. It is designed to operate with either biased or non biased detectors. It is compatible with uncooled detectors in TO39 package (SIP-TO39) or thermoelectrically cooled detectors in TO8 package (SIP-TO8). SIP is dedicated for OEM applications and requires external heatsink (MHS-2). There is a possibility to adjust gain (devices with a frequency bandwidth up to 100 MHz).

## Specification ( $T_a = 20^\circ\text{C}$ )

Parameter	Typical value	Conditions, remarks
Low cut-off frequency $f_{lo}$ , Hz	DC, 10, 100, 1k, 10k	
High cut-off frequency $f_{hi}$ , Hz	100k, 1M, 10M, 100M, 250M	
Transimpedance $K_v$ , V/A	up to 100k	tunable
Transimpedance range $K_{i,max}/K_{i,min}$	up to 5	dependent on $f_{hi}$
Output impedance $R_{out}$ , $\Omega$	50	
Output voltage swing $V_{out}$ , V	$\pm 10$ $\pm 1$	$f_{hi} \leq 1 \text{ MHz, } R_L = 1 \text{ M}\Omega^*)$ $f_{hi} > 1 \text{ MHz, } R_L = 50 \text{ }\Omega^*)$
Output voltage offset $V_{off}$ , mV	max $\pm 20^{**})$	
Power supply voltage $V_{sup}$ , V	$\pm 15$ $\pm 9$	$f_{hi} \leq 1 \text{ MHz}$ $f_{hi} > 1 \text{ MHz}$
Power supply current $I_{sup}$ , mA	max $\pm 50$	no detector biasing
Ambient operating temperature $T_{op}$ , $^\circ\text{C}$	10 to 30	
Signal output socket	MMCX	
Power supply and TEC control socket	AMP2x4 (male)	AMPMODU 2x4
Mounting hole	none	
Fan	no	external heatsink necessary

<sup>\*)</sup>  $R_L$  – load resistance

<sup>\*\*)</sup> Measured with equivalent resistor at the input instead of the detector, it is to avoid the environmental thermal radiation impact.



SIP-TO8

SIP-TO39

## Types of VIGO detectors that can be integrated with SIP-TO8 preamplifier

- **Photoconductive**  
PC-2TE, PC-3TE, PC-4TE
- **Photoconductive optically immersed**  
PCI-2TE, PCI-3TE, PCI-4TE
- **Photovoltaic**  
PV-2TE, PVA-2TE, PV-3TE, PV-4TE
- **Photovoltaic optically immersed**  
PVI-2TE, PVIA-2TE, PVI-3TE, PVI-4TE
- **Photovoltaic multiple junction**  
PVM-2TE
- **Photovoltaic multiple junction optically immersed**  
PVMI-2TE, PVMI-3TE, PVMI-4TE

## Types of VIGO detectors that can be integrated with SIP-TO39 preamplifier

- **Photoconductive**  
PC
- **Photoconductive optically immersed**  
PCI
- **Photovoltaic**  
PV, PVA
- **Photovoltaic optically immersed**  
PVI, PVIA
- **Photovoltaic multiple junction**  
PVM
- **Photovoltaic multiple junction optically immersed**  
PVMI

## Features

- Very small size
- Frequency bandwidth up to 250 MHz
- Adjustable gain as an option

## Code description

Type	$f_{lo}$ , Hz	$f_{hi}$ , Hz	Detector package	Version
SIP	DC	100k	TO8 TO39	<b>G</b> (with gain adjustment) <b>NG</b> (without gain adjustment)
	10	1M		
	100	10M		
	1k	100M		
	10k	250M		

<sup>\*)</sup> Only for SIP preamplifier with  $f_{hi} \leq 100 \text{ MHz}$ .

### Power supply and TEC control socket AMPMODU 2×4 (male)

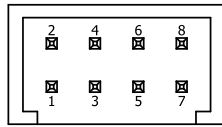

Function	Symbol	Pin number
Power supply input (-)	-V <sub>sup</sub>	1
Thermistor output/Not connected	TH2/N.C.	2 <sup>*)</sup>
Data pin/Ground	DATA/GND	3 <sup>**)</sup>
TEC supply input (-)/Not connected	TEC-/N.C.	4 <sup>*)</sup>
Ground	GND	5
Thermistor output/Not connected	TH1/N.C.	6 <sup>*)</sup>
Power supply input (+)	+V <sub>sup</sub>	7
TEC supply input (+)/Not connected	TEC+/N.C.	8 <sup>*)</sup>

Notes:

<sup>\*)</sup> N.C. – only for SIP-TO39 version.

<sup>\*\*)</sup> GND – only for SIP-TO39 version.

### Included accessories

- › MMCX-BNC, AMP2×4-DB9 cables

### Dedicated accessories for SIP-TO8

- › PTCC-01-BAS TEC controller + **USB: TypeA-MicroB cable + AC adaptor**
- › PTCC-01-ADV TEC controller + **USB: TypeA-MicroB cable + AC adaptor**
- › PTCC-01-OEM TEC controller + **USB: TypeA-MicroB, KK2-POWER cables**
- › MHS-2 heatsink

### Dedicated accessories for SIP-TO39

- › PPS-03 preamplifier power supply + **AC adaptor**

### Mechanical layout, mm SIP-TO8

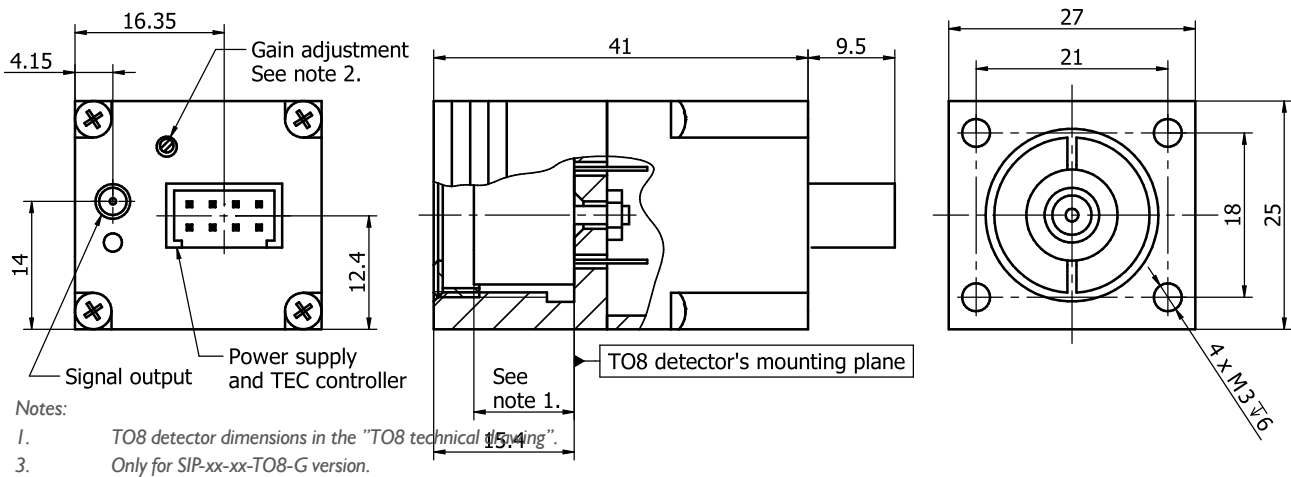

Notes:

1. TO8 detector dimensions in the "TO8 technical drawing".
3. Only for SIP-xx-xx-TO8-G version.

### SIP-TO39

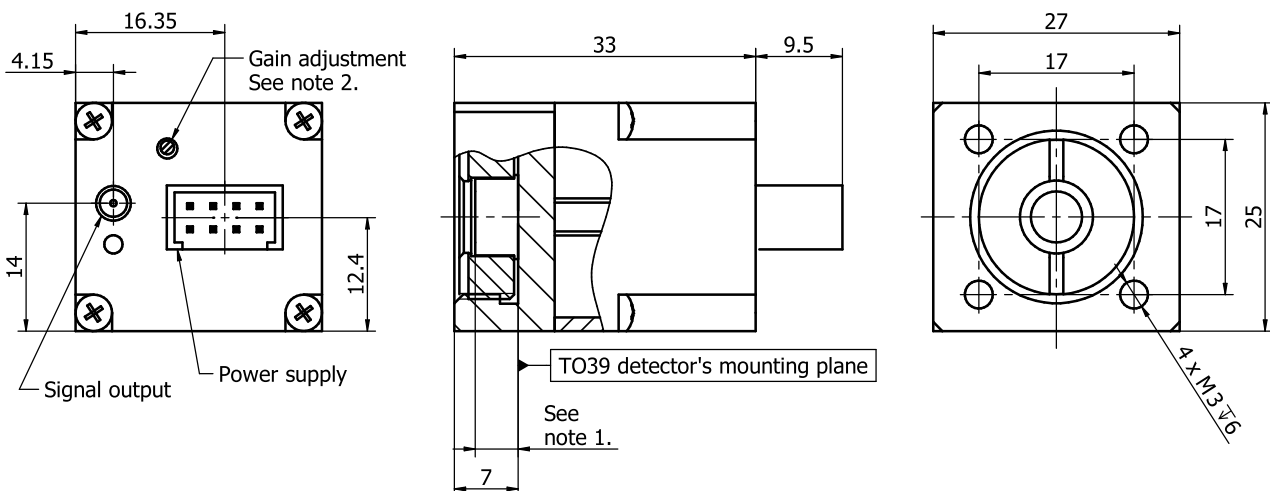

Notes:

1. TO8 detector dimensions in the "TO39 technical drawing".
2. Only for SIP-xx-xx-TO39-G version.