

DATASHEET AND OPERATING GUIDE

USBKIT

USB Interface Kit

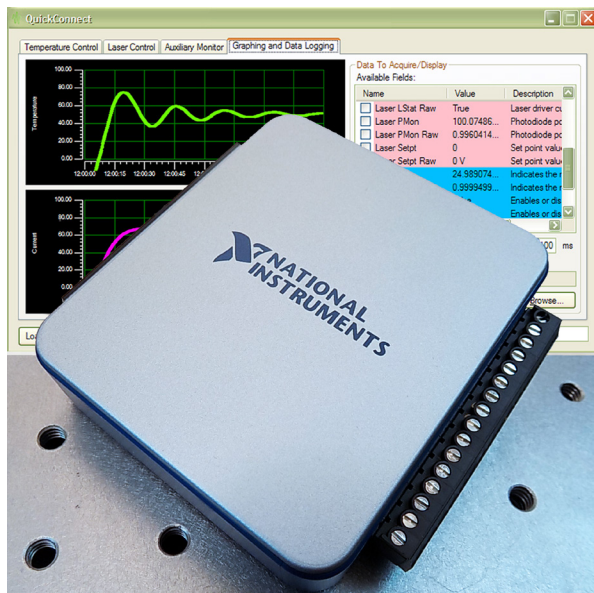

FEATURES AND BENEFITS

- Includes Digital-to-Analog (D/A) converter for remote setpoint control of laser driver or temperature controller
- Analog-to-Digital (A/D) converters are used to monitor actual laser diode current or temperature
- Auxiliary A/D can be configured as a single 14-bit differential input or two 13-bit single-ended inputs
- Software can control one laser diode driver, one temperature controller, an auxiliary monitor, and provides full graphing and datalogging
- Save multiple setups for easy repeatable experiments or manufacturing testing

COMPUTERIZE THE WAVELENGTH ADVANTAGE

Expand the capabilities of your Wavelength Electronics drivers and controllers with the USBKIT and QuickConnect™ software. The USBKIT provides convenient computer control of most Wavelength chassis mount controllers and PCB-mounted devices with evaluation boards.

The software provides an intuitive virtual control panel that allows you to leverage the low-noise, high-stability laser diode and temperature control capabilities of Wavelength's components to save time and money.

PLUG-IN CONVENIENCE FOR OEMS

Build the USBKIT into your OEM laser system and enjoy the convenience of closed-cover system calibration and troubleshooting—all you need is the USB cable that comes with the USBKIT.

The software is built on the Windows .NET framework so you can write your own code for a manufacturing test system, a field-calibration kit, or for laboratory applications.

CONTENTS

	PAGE
QUICKCONNECT™ QUICK START	2
USBKIT FUNCTIONS AND COMPATIBILITY	2
PIN DESCRIPTIONS	3
SPECIFICATIONS	4
SAFETY INFORMATION	5
SOFTWARE INSTALLATION INSTRUCTIONS	6
OPERATING INSTRUCTIONS	8
ADDITIONAL TECHNICAL INFORMATION	18
TROUBLESHOOTING	22
MECHANICAL SPECIFICATIONS	23
CERTIFICATION AND WARRANTY	24

ORDERING INFORMATION

PART NO	DESCRIPTION
USBKIT	Customized National Instruments D/A card, plus QuickConnect™ software



QUICKCONNECT™ QUICK START

Review the entire datasheet before operating the USBKIT and the QuickConnect™ Software.

- Load National Instruments NI-DAQ software, Microsoft .NET Framework, and Wavelength's QuickConnect™ application from the included CD. (See **page 6**)
- Connect USBKIT to PC using the included USB cable.
- Start QuickConnect™. Use Ctrl-O to open a device and select the USBKIT that is attached to the computer. (See **page 8**.) Multiple USBKITS can be connected to one computer.
- Select the Wavelength product, and wire it according to the onscreen diagram. An example wiring diagram is shown in **Figure 1**, at right. The wiring diagram displayed in the software is determined by the controller that is selected. All product wiring diagrams can be found in the Additional Technical Information section (**page 18**).
- Select and calibrate the temperature sensor, and set up the optional temperature limits. (See **page 10**.)
- Select the laser diode driver model and wire it according to the onscreen diagram. (See **page 14**.)
- Wire one auxiliary signal differentially (14-bit resolution) or two signals in single-ended mode (each with 13-bit resolution). (See **page 15**.)
- Select which fields to display in the onscreen strip charts. (See **page 16**.)
- Select which data fields to log, and enter the file name.
- Save the settings to a Configuration file if the same setup will be used again in the future.

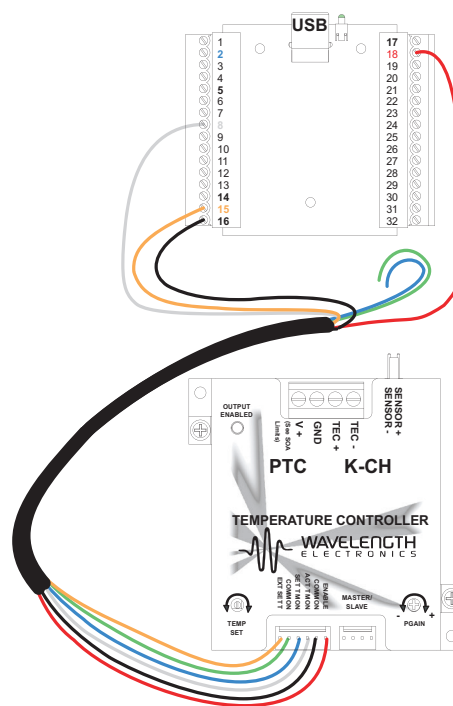

Figure 1. Example Wiring Diagram



SPECIAL ATTENTION TO ELECTRICAL GROUNDING IS REQUIRED WHEN USING THE USBKIT. REFER TO **PAGE 18** FOR DETAILS.

USBKIT FUNCTIONS AND COMPATIBILITY

PRODUCT FAMILY	PRODUCTS	TEMPERATURE SETPOINT CONTROL	TEMPERATURE CONTROLLER ENABLE	ACTUAL TEMPERATURE MONITOR	TEMPERATURE SETPOINT MONITOR	LASER SETPOINT CONTROL	LASER OUTPUT ENABLE	ACTUAL LASER CURRENT MONITOR	PD CURRENT MONITOR	LASER CURRENT LIMIT MONITOR	LIMIT STATUS
PTC-CH Family	PTC2.5K-CH PTC5K-CH PTC10K-CH	X	X	X	-	-	-	-	-	-	-
PTC PCB Family	PTC5000 PTC10000	X	X	X	-	-	-	-	-	-	-
LDTC 2-2 Family	LDTC 2-2 0 LDTC 2-2 E	X	-	X	X	X	X	X	X	-	-
LDTCxx20 Family	LDTC0520 LDTC1020	X	-	X	X	X	X	X	X	-	-
PLD-CH Family	PLD5K-CH PLD10K-CH PLD12.5K-CH	-	-	-	-	X	X	X	X	X	X
PLD PCB Family	PLD200 + EVAL PLD500 + EVAL PLD1250 + EVAL PLD5000 + EVAL PLD6500 + EVAL	-	-	-	-	X	X	X	X	X	X
PLD10EV	PLD10000 + EVAL PLD12500 + EVAL	-	-	-	-	X	X	X	X	X	X

Other Wavelength products can be interfaced to the USBKIT. Contact the factory for details.

PIN DESCRIPTIONS

Table 1. Pin Descriptions

PIN	NAME	FUNCTION	PIN DESCRIPTION
2	AI.0	Input	LD Current Monitor; 14-bit analog input, referenced to ground
5	AI.1	Input	PD Current Monitor; 13-bit analog input, referenced to ground
6	AI.5	Input	LD Current Limit Monitor; 13-bit analog input, referenced to ground
8	AI.2	Input	Actual Temperature Monitor, 13-bit analog input, referenced to ground
9	AI.6	Input	Temperature Setpoint Monitor, 13-bit analog input, referenced to ground [Rev. A & Rev. B this pin was ground.]
11	AI.3	Aux Monitor	Aux Monitor 1; 13-bit single-ended or 14-bit differential analog input (see page 15)
12	AI.7	Aux Monitor	Aux Monitor 2; 13-bit single-ended or 14-bit differential analog input (see page 15)
13	GND	Ground	Ground connection for Aux Monitor inputs
14	AO.0	Output	LD Setpoint; 12-bit analog output
15	AO.1	Output	Temperature Controller Setpoint; 12-bit analog output
16	GND	Ground	Ground connection for the LD and TC Setpoints
17	PO.0	Output	LD Enable; digital output
18	PO.1	Output	Temperature Controller Enable; digital output
19	PO.2	Input	Limit Status Monitor, digital input



Figure 2. USBKIT Top View

Table 2. Hardware and Software Revision Compatibility

HARDWARE REVISION	SOFTWARE REVISION	RESULT
C	2.2 or earlier	ACT T MON is not valid. Ground SET T MON (Pin 9) to restore ACT T MON.
A or B	2.3.5 or later	SET T MON will always read zero (0).

SPECIFICATIONS

PARAMETER	VALUE	UNIT	NOTE
Size	3.2 x 2.8 x 1.2	in	81.3 x 71.1 x 30.5 mm
Weight	2	oz	56 grams
Supply Voltage	USB Bus Powered		
USB Interface	Full Speed, Self-Powered USB 2.0		
Operating Temperature	0 to 55	°C	
Storage Temperature	-40 to 85	°C	
A/D Resolution	13 bits (x2) or 14 bits (x1)		(2x) Single-ended inputs or (1x) Differential input
D/A Resolution	12	bits	(x2) outputs available; for setpoint control of laser driver and temperature controller

COMPUTER SYSTEM REQUIREMENTS			
Operating System Compatibility (US English Edition)	Windows 7, 7 SPI, 8.1, and 10	<u>x86 (32-bit)</u> X	<u>x64 (64-bit)</u> X
Installation Prerequisites QuickConnect version 2.3.6 and earlier (Available for free from Microsoft and National Instruments websites.)		.NET Framework 4.0 NI-DAQmx 9.6.x	
Installation Prerequisites QuickConnect version 2.4.0 and later		.NET Framework 4.0 NI-DAQmx 15.1.1f3	
Installation Prerequisites QuickConnect version 2.6.5 and later		NET Framework 4.0 NI-DAQmx 16.0.0f	
Memory		1 GB	2GB

SAFETY INFORMATION

SAFE OPERATING AREA – DO NOT EXCEED INTERNAL POWER DISSIPATION LIMITS

Before attempting to operate your Wavelength Electronics laser driver or temperature controller, it is critical that you first determine if the hardware will be operating within the Safe Operating Area (SOA).

Consult the instructions for calculating the SOA online. For laser drivers:

www.teamwavelength.com/support/design-tools/soa-ld-calculator/

For temperature controllers:

www.teamwavelength.com/support/design-tools/soa-tc-calculator/



TO ENSURE SAFE OPERATION, IT IS IMPERATIVE THAT YOU DETERMINE IF THE UNIT IS GOING TO BE OPERATING WITHIN THE INTERNAL HEAT DISSIPATION SAFE OPERATING AREA (SOA).

If you have any questions about the Safe Operating Area calculator, call the factory for free and prompt technical assistance.

ELECTRICAL GROUNDING CONSIDERATIONS WHEN USING USB PERIPHERALS

Special attention must be paid to electrical grounding when using USB peripherals. Refer to **page 18** for more information.

It is critical to trace ground paths when using laser drivers and temperature controllers that are computer controlled via USB. In some cases, ground loops can degrade system performance; in extreme cases dangerously high potential differences can damage or destroy sensitive components.

If you have questions regarding grounding your laser driver or temperature controller when using the USBKIT, contact Wavelength Electronics for free and prompt technical assistance.

THEORY OF OPERATION

The USBKIT and QuickConnect™ software provide convenient computer control of most Wavelength chassis mount controllers and evaluation boards.

The USBKIT hardware board is customized by National Instruments for Wavelength Electronics. The QuickConnect™ software is written by Wavelength Electronics to allow easy out-of-the-box computer control of the USBKIT.

The USBKIT follows standard USB communication and power protocols, and requires no external power supply. The screw terminal connectors allow for a wide range of connectivity options to Wavelength Electronics' laser drivers and temperature controllers.

QuickConnect™ includes profiles for a variety of Wavelength products. Application flexibility is enhanced with adjustable temperature sensor and photodiode calibration constants, and the graphing and datalogging functions are customizable real-time.

If your application requirements are different than what is offered with the standard software, Wavelength can generate a custom profile, or you can develop your own source code with the .NET Framework.

SOFTWARE INSTALLATION INSTRUCTIONS

Three pieces of software must be installed in order to use the USBKIT. These three programs will be installed in this sequence:

- National Instruments NI-DAQ software
- Microsoft .NET Framework
- Wavelength Electronics QuickConnect™ Application (QCA)

NATIONAL INSTRUMENTS NI-DAQ SOFTWARE

Follow these instructions to install the NI-DAQ software:

- Download the **NI-DAQmx device drivers** from www.teamwavelength.com/download/software/NIDAQ1600f0.zip
- Right click on the ZIP file and click *Extract All*.
- The **Extract Compressed (Zipped) Files** dialog will appear. Check the box labeled **Show extracted files when complete** and click the *Extract* button.
- When extraction is complete, a new window will appear. Doubleclick *setup.exe*.
- Windows will prompt you to confirm allowing the installer to make changes to your computer. Click *Yes*. The introductory screen will prompt you to close all applications.
- Choose the installation directory, then click *NEXT*.
- Choose which options to install. The QCA requires installation of the **.NET Framework 4.0 Languages**. Click the X icon next to this option to change it to the Install icon (see **Figure 3**). It is not necessary to install the Examples and Visual Studio Integration items; these are optional. Click *NEXT*.

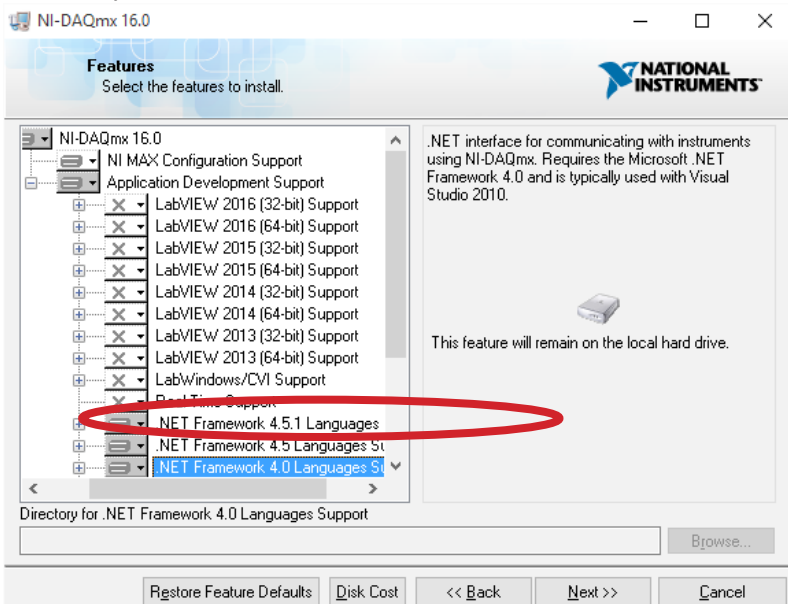

Figure 3. National Instruments NI-DAQ Software Installation

- Next, two License Agreement screens will appear; click *NEXT* on each of them.

- Review the Installation options, shown on the screen in **Figure 4**.

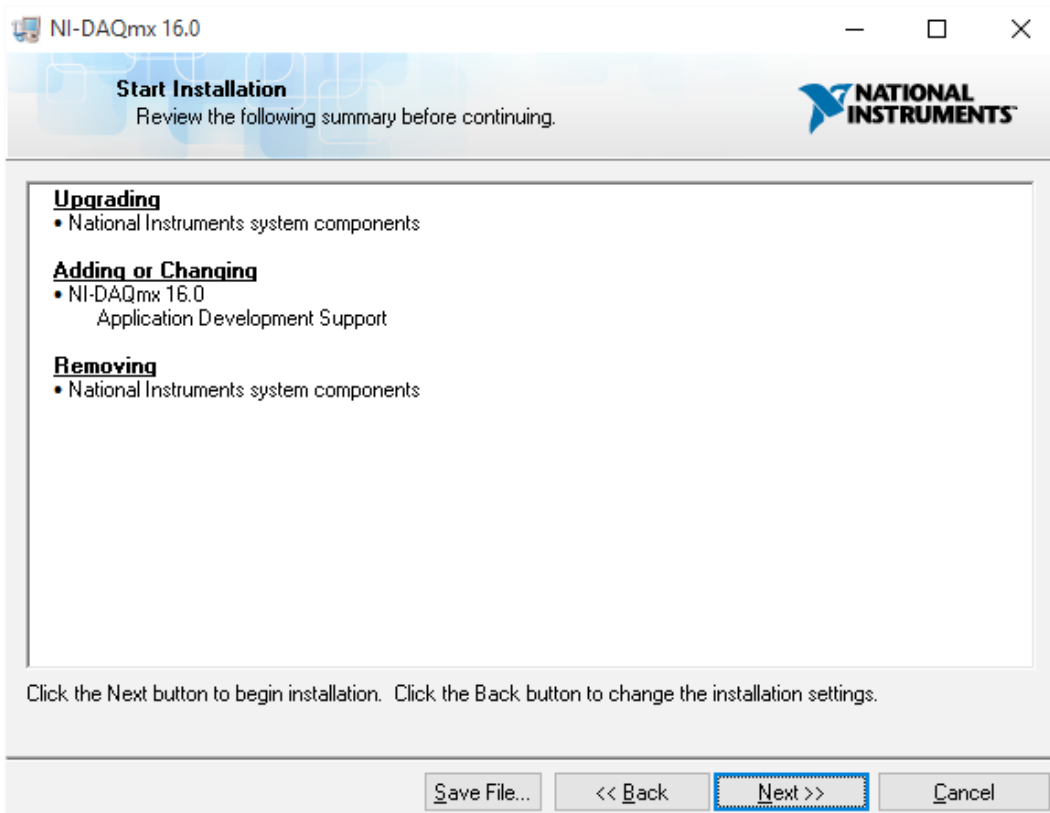

Figure 4. Installation Review Screen

- If the installation review window does not indicate the options shown in **Figure 4**, click the BACK button to add the options. When the right options are selected for install, click the NEXT button.
- An installation status dialogue window appears while the software is loaded, and is followed by an Installation Complete window.
- The Installation Complete window will ask if you want to restart the computer. The restart can be put off until after the other two pieces of software are installed.

MICROSOFT .NET FRAMEWORK

- If the .NET Framework 4.0 is already installed on the computer, skip to installing the QuickConnect Application.
- Download **Microsoft .NET framework** from www.teamwavelength.com/download/software/dotnetfx.exe
- Doubleclick *dotnetfx.exe*.
- Read the Microsoft License Agreement, then click the **ACCEPT** button
- While the two files are installed, an **installation status** dialogue window appears.
- Next the **Installation Complete** window appears. You can choose to restart the computer at this point, or the restart can be put off until after the Quick Connect Application is installed.

WAVELENGTH ELECTRONICS' QUICKCONNECT APPLICATION

- Download the USBKIT application software from www.teamwavelength.com/download/software/usbskit-2.6.5-e.msi
- Doubleclick *Setup.exe*. After the Setup Wizard window appears, click the **NEXT** button.
- Choose the installation folder, or use the default folder.
- Choose whether the program is available to all users, or only to the user currently logged in. Click the **NEXT** button.
- The **Confirmation** window will appear. Click **NEXT** to begin installation.
- When installation is finished, the **Installation Complete** screen appears. Close the window.
- Restart the computer.

OPERATING INSTRUCTIONS

Follow these instructions to connect the National Instruments USBKIT to your computer and Open the device for communication.

- Plug in the included USB cable to the USBKIT, then plug in the other end to a USB port on the computer. A National Instruments dialogue window will open; click CANCEL to exit the window.
- From the Windows Start menu, choose Programs → Wavelength Electronics → USBKit QuickConnect. The QuickConnect application will launch.
- In the top menu, select Device → Open, as indicated in **Figure 5**.

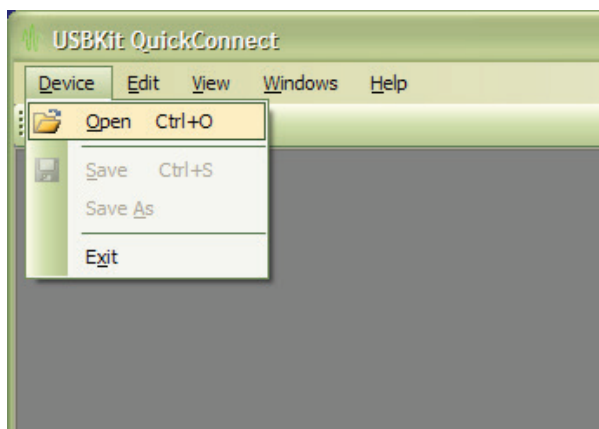

Figure 5. Device Open Menu Selection

- All USB-connected devices appear in the window shown in **Figure 6**. (The current version will show as USB-6001. The prior version as USB-6009.)

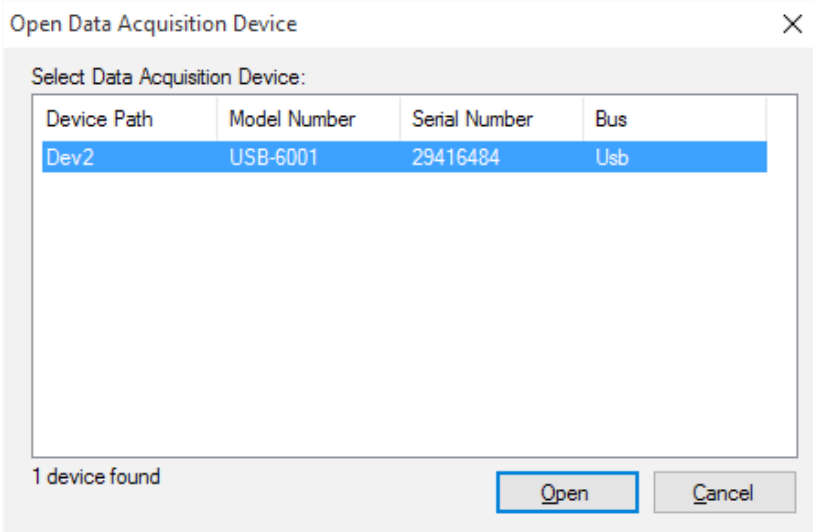

Figure 6. Open Data Acquisition Device Window

- Highlight the USB device you wish to operate with the QCA, then click OPEN.
- Click Exit from this menu to close the software.

The QuickConnect window then opens, shown in **Figure 7**.

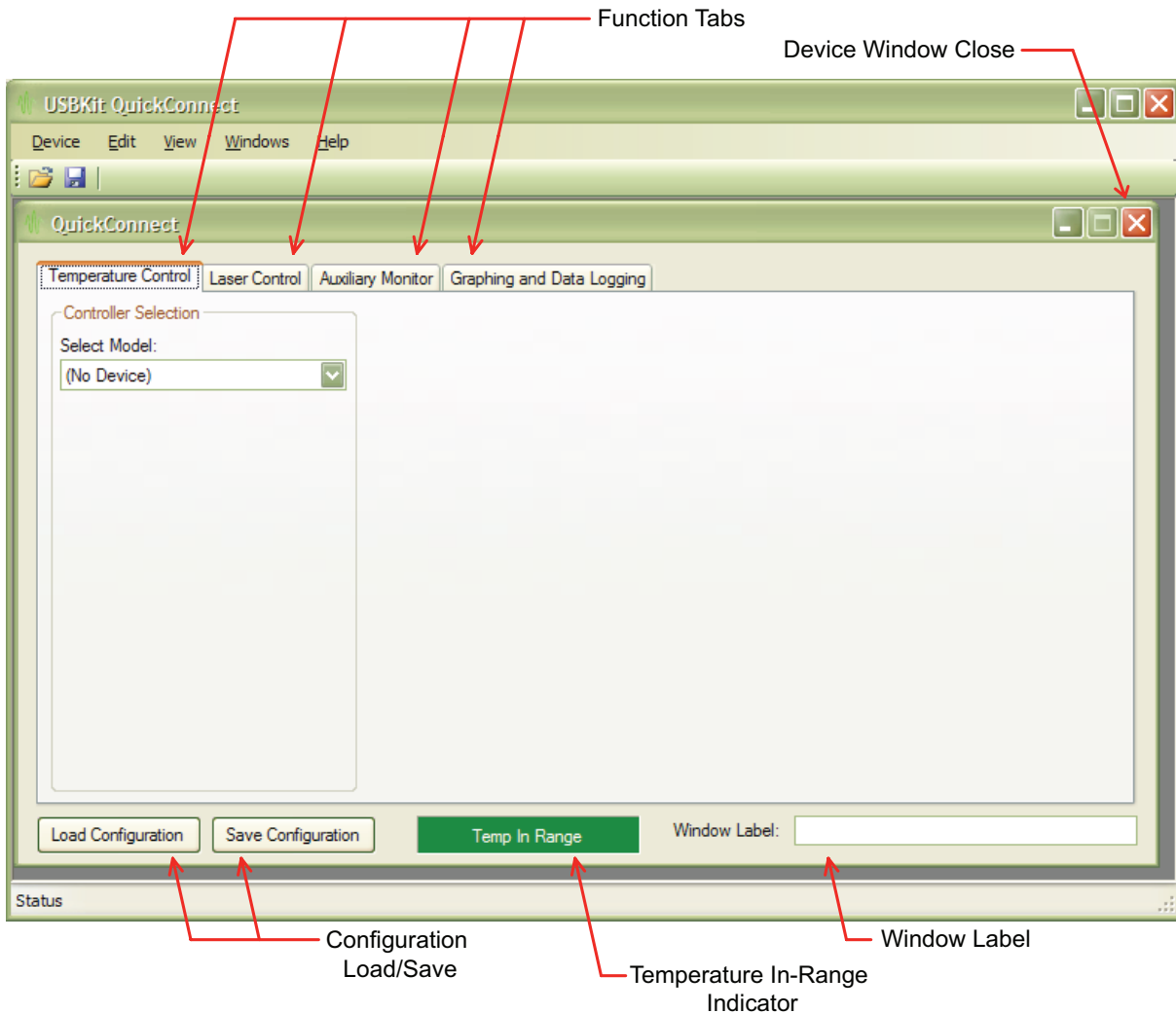

Figure 7. QCA Window

- Once you have finished configuring the QCA for your current application, use the Save Configuration button so that you can easily reload the configuration later. The default storage location is the My Documents directory.



NOTE: THE LASER DIODE ENABLE STATUS IS SAVED WHEN THE CONFIGURATION IS SAVED. IF THE LASER DIODE OUTPUT IS ENABLED WHEN THE CONFIGURATION IS SAVED, THE LASER DIODE OUTPUT WILL BE ENABLED WHEN THE CONFIGURATION IS RELOADED.

- Use the Load Configuration button to select a previously saved QCA configuration.
- The Temp In Range appears on all screens throughout the QuickConnect™ application, and indicates whether or not the temperature sensor is within the safe range that you have defined. If the sensor indicates an out of range temperature, the box switches to red to indicate Temp Out Of Range. Instructions for setting the minimum and maximum safe temperatures are found on **page 10**.

- If you have more than one National Instruments card operating on the computer, use the Window Label feature to identify which QCA window applies to each card.
- The Function Tabs are used to configure the temperature controller, laser driver, auxiliary inputs, and datalogging and graphing, and are discussed in detail in the following pages.

DEVICE SHUTDOWN BEHAVIOR

Clicking the Device Window Close button will safely disable the laser driver output. The temperature controller output will remain enabled until the USBKIT is disconnected from the computer.

USBKIT behavior is undefined if power to the USBKIT is removed while there are active devices attached and/or enabled.

OPERATING THE TEMPERATURE CONTROLLER

From the screen shown in **Figure 7**, click the Temperature Control tab, then click the Select Model pull down menu. Select the temperature control model you are using. The wiring diagram and control screen will appear, shown in **Figure 8**. Carefully wire the hardware according to the diagram. Wiring diagrams can also be found in the Additional Technical Information section (**page 18**) of this datasheet.

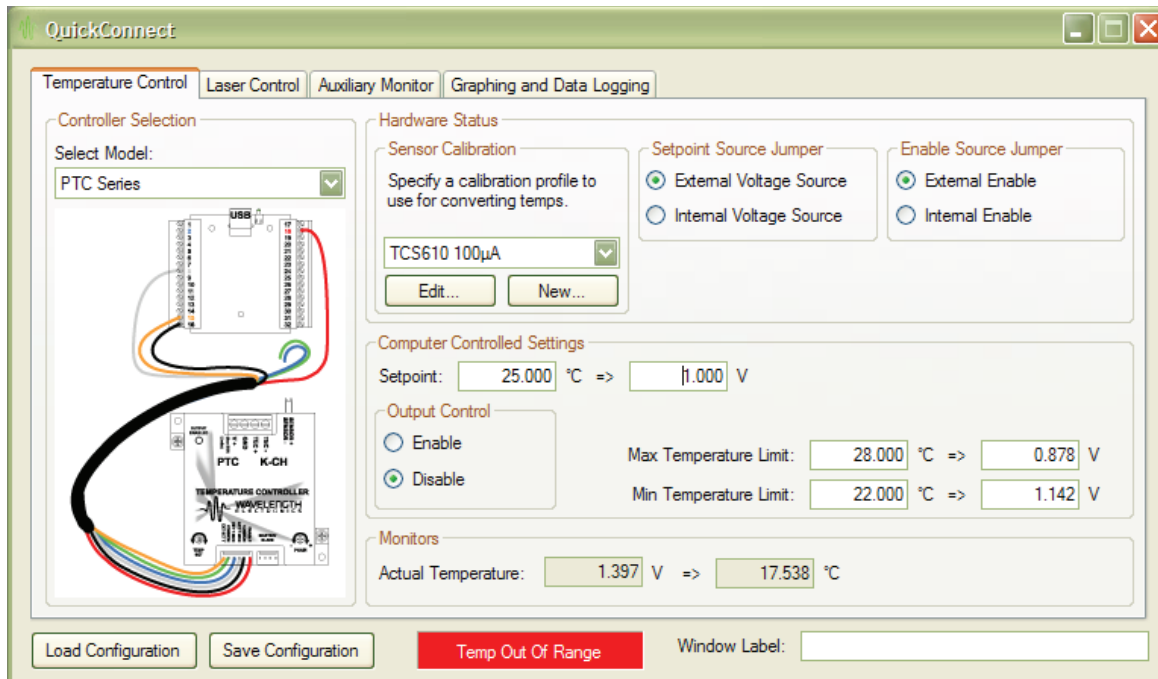

Figure 8. Temperature Controller Screen

Hardware Status Section

First, follow the operating guide for the temperature controller you are using, and then configure the QCA to mirror the hardware settings. The content of this section depends on the hardware; **Figure 8** shows the screen for the PTCxK-CH Series.

Configure the settings in the different sections according to your application.

- **Sensor Calibration:** Choose the sensor and the bias current. Click Edit to calibrate the selected sensor, or click New to create a custom calibrated sensor. Sensor Calibration is discussed in detail on **page 11**.
- **Setpoint Source Jumper:** Match the software setting to the hardware configuration. (The PTCxK-CH uses a jumper to reference the setpoint signal from an onboard trimpot circuit or from an external input.)
- **Enable Source Jumper:** Check the appropriate radio button to reflect the Enable configuration of the temperature controller. If the hardware is enabled to use the Internal Enable signal, the software controls will not be able to enable/disable the output.

Computer Controlled Settings

- If **External Voltage Source** is chosen for the Setpoint Source, a field for Setpoint is displayed in the Computer Controlled Settings section. When a calibrated sensor is used, enter either the sensor voltage or setpoint temperature.
- The **Output Control** section is active if **External Enable Signal** is selected in the Hardware Status section. An Output Control Enable / Disable radio button appears to allow software control of the output. Click Enable to enable the output current; clicking the Disable radio button disables the controller output.
- **Maximum and Minimum Temperature Limits:** Specify a sensor voltage, or if the sensor is calibrated, the temperature in Celsius. The values entered in this section control the Temp In Range indicator at the bottom of the screen.
- **Monitors** Section: The voltage from the temperature sensor is displayed. If you have chosen a calibrated sensor (see Hardware section), the voltage will be converted to degrees Celsius and displayed in this section. On the LDTC and PTC modules, if you choose internal voltage source for setpoint, setpoint voltage or temperature will be displayed so you can adjust the onboard trimpot.

THERMISTOR SENSOR CALIBRATION

Access the Thermistor calibration screen by clicking Edit under the sensor selection pull down menu that appears on the Temperature Control screen. The thermistor calibration screen is shown in **Figure 9**, with the values for the default 10 k Ω TCS610 thermistor available from Wavelength.

Edit Temperature Sensor Profile

Thermistor RTD Linear

The software uses resistance/temperature pairs to curve fit to the Steinhart-Hart equation. You can either enter three data pairs or use the Steinhart-Hart tool on the bottom of the screen to generate these resistance/temperature pairs.

Calibration Pairs

	Pair 1	Pair 2	Pair 3	
Temperature:	10.00	25.00	40.00	Bias Current: 100.00 μ A
Resistance:	1.9900e+004	1.0000e+004	5.3260e+003	

Steinhart-Hart Calibration Parameters

Conversion: => Ω Use as:
 Temperature Resistance

Description: 10K@25°C Thermistor, 100 μ A Bias

Sensor Name: TCS610 100 μ A

Figure 9. Thermistor Sensor Calibration

There are two different ways to calibrate the thermistor: either by entering the Resistance-Temperature (RT) pairs directly, or by calculating them based on the Steinhart-Hart constants.

When entering calibration values, select a temperature range that encompasses the actual range of your application.

Calibration Pairs

Measure the resistance of your sensor at three different temperatures, then enter the RT pairs in this section.

Enter the Bias Current that is configured on the temperature controller. The value entered in the software must match the actual sensor current in order for the QCA to accurately calculate temperature values, setpoint values, and to accurately set the Temp In Range indicator.

Steinhart-Hart Calibration Parameters

If you know the Steinhart-Hart coefficients of your thermistor but not RT pairs, use the conversion tool and enter the A, B, and C coefficients of your thermistor.

In the Conversion section, enter either a temperature or resistance value. If you've entered a temperature, click the Temperature radio button; if you've entered a resistance, click the Resistance radio button.

Then press the Convert button and the matching value will appear, thereby creating an RT pair. You can transfer the value to the Calibration Pairs section by clicking one of the Use As buttons (*Pair 1*, *Pair 2*, or *Pair 3*) at the right of the screen.

Enter the Sensor Name and Description

Once the sensor is calibrated, enter a Description and a Name. The first 22 characters of the Name will be listed in the drop down menu on the Temperature Control page. Click OK to save the calibrated sensor.

RTD CALIBRATION

Access the RTD calibration screen by clicking Edit under the sensor selection pull down menu that appears on the Temperature Control screen. Then select the RTD tab at the top of the screen. The RTD calibration screen is shown in **Figure 10**.

Edit Temperature Sensor Profile

Themistor **RTD** Linear

The software uses a simplified Callendar/Van Dusen equation to convert the RTD's resistance to temperature. You can specify resistance/temperature pairs in the Calibration Pairs group to derive the Callendar/Van Dusen coefficients or enter them directly in the Calibration Parameters group at the bottom.

Calibration Pairs

	At 0°C	Pair 2	Pair 3	
Temperature:	<input type="text"/>	<input type="text"/>	<input type="text"/>	Bias Current: <input type="text"/> mA
Resistance:	<input type="text"/>	<input type="text"/>	<input type="text"/>	

Callendar-Van Dusen Calibration Parameters

R at 0°C:

Beta 1:

Beta 2:

Description:

Sensor Name:

OK Cancel

Figure 10. RTD Sensor Calibration

There are two different ways to calibrate the RTD sensor: either by entering the Resistance-Temperature (RT) pairs directly, or by entering the Callendar-Van Dusen calibration parameters.

When entering calibration values, select a temperature range that encompasses the actual range of your application.

Calibration Pairs

Measure the resistance of your sensor at 0°C and at two other temperatures, then enter the RT pairs in this section.

Enter the Bias Current that is configured on the temperature controller. The value entered in the software must match the actual sensor current in order for the QCA to accurately calculate temperature values, setpoint values, and to accurately set the Temp In Range indicator.

Callendar-Van Dusen Calibration Parameters

Enter the resistance at 0°C, and enter the Beta 1 and Beta 2 values from the RTD datasheet.

Enter the Sensor Name and Description

Once the sensor is calibrated, enter a Description and a Name. The first 22 characters of the Name will be listed in the drop down menu on the Temperature Control page. Click OK to save the calibrated sensor.

LINEAR SENSOR CALIBRATION— AD590, LM335

Access the linear sensor calibration screen by clicking Edit under the sensor selection pull down menu that appears on the Temperature Control screen. Then select the Linear tab at the top of the screen. The linear sensor calibration screen is shown in **Figure 11**.

Edit Temperature Sensor Profile

Themistor RTD **Linear**

The software uses slope-intercept linear calculation to convert the measured sensor voltage to temperature. You can enter the slope and offset into the Calibration Parameters section or enter two points on the sensor's response curve and the slope and offset will be computed by the software.

Calibration Pairs

	Pair 1	Pair 2
Temperature:	<input type="text"/>	<input type="text"/>
Voltage:	<input type="text"/>	<input type="text"/>

Calibration Parameters

Slope:

Offset:

Description:

Sensor Name:

Figure 11. Linear Sensor Calibration

There are two different ways to calibrate the linear sensor: either by entering the Resistance-Temperature (RT) pairs directly, or by entering the slope and offset calibration parameters.

When entering calibration values, select a temperature range that encompasses the actual range of your application.

Calibration Pairs

Measure the resistance of your sensor at two different temperatures, then enter the RT pairs in this section. The software will calculate the slope and offset values from these two RT pairs.

Slope and Offset Calibration Parameters

Enter the slope and offset calibration values from the linear temperature sensor datasheet.

Enter the Sensor Name and Description

Once the sensor is calibrated, enter a Description and a Name. The first 22 characters of the Name will be listed in the drop down menu on the Temperature Control page. Click OK to save the calibrated sensor.

OPERATING THE LASER DRIVER

From the screen shown in **Figure 7**, click the Laser Control tab, then click the Select Model pull down menu. Select the laser driver model you are using. The wiring diagram and control screen will appear, shown in **Figure 12**. Carefully wire the hardware according to the diagram. Wiring diagrams can also be found in the Additional Technical Information section (**page 18**) of this datasheet.

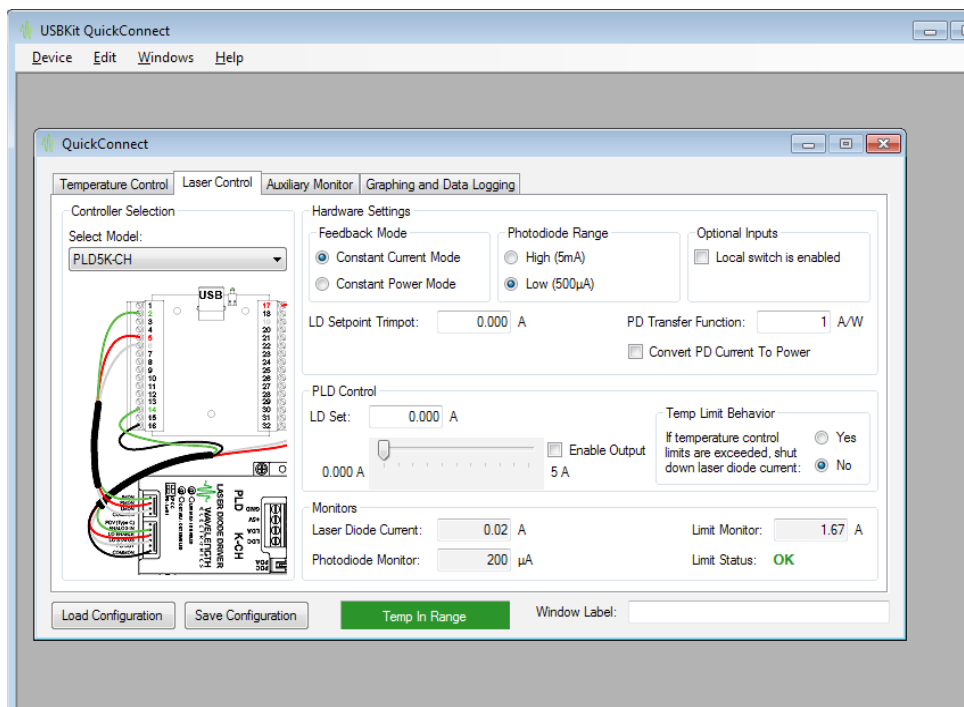

Figure 12. Laser Control Screen

Hardware Settings Section

First, follow the operating guide for the laser driver you are using, and then configure the QCA to mirror the hardware settings. The content of this section depends on the hardware; **Figure 12** shows the screen for the PLDxK-CH Series. Configure the settings in the different sections according to your application.

- **Feedback Mode:** Set the QCA feedback mode to match the feedback mode setting on the hardware.
- **Photodiode Range:** The photodiode feedback range must match the hardware setting. If the settings do not match the photodiode feedback monitor will not be accurate, and the laser might be damaged.
- **Optional Inputs:** If the Enable / Disable switch is disabled on the driver, the software cannot override it. This section is included simply as an on-screen reminder of the hardware configuration.
- **LD Setpoint Trimpot:** If the onboard trimpot is set to a non-zero value, enter the output current in this box. The software will use this value as the bottom limit for output current adjustment.
- **PD Transfer Function:** Check Convert PD Current to Power and enter a transfer function, as specified in the laser diode datasheet, to convert PD current to laser output power.

PLD Control Settings

- **LD Set:** Enter the drive current setpoint directly or use the slider to set the output current.
- **Enable Output:** Click this box to enable the driver output.
- **Temp Limit Behavior:** The USBKIT can be configured to disable the laser driver output if the temperature controller senses the load is outside the temperature limits set on the Temperature Control page.

Monitors Section

- The driver output current is shown in the Monitors section. The actual laser diode drive current value is calculated from the voltage measured on the monitor pin, and displayed in the Monitors section.
- The photodiode monitor current is displayed. If the Convert PD Current To Power box is checked in the Hardware Settings section, the equivalent laser output power is also displayed.
- The current limit monitor value is displayed. This feature can be used to monitor adjustments to the current limit.
- **Limit Status:** as long as the driver has not indicated an over-limit condition, the Limit Status field indicates OK. Refer to the datasheet for the laser driver for instructions on resetting the limit status indicator.

USING THE AUXILIARY MONITORS

Two A/D inputs are available on the USBKIT, and can be used in two different ways: a 14-bit differential input, or two single-ended 13-bit inputs. On the Auxiliary Monitor tab, shown in **Figure 13**, check the appropriate radio button at the top of the screen. Carefully wire the hardware according to the wiring diagram that is displayed.

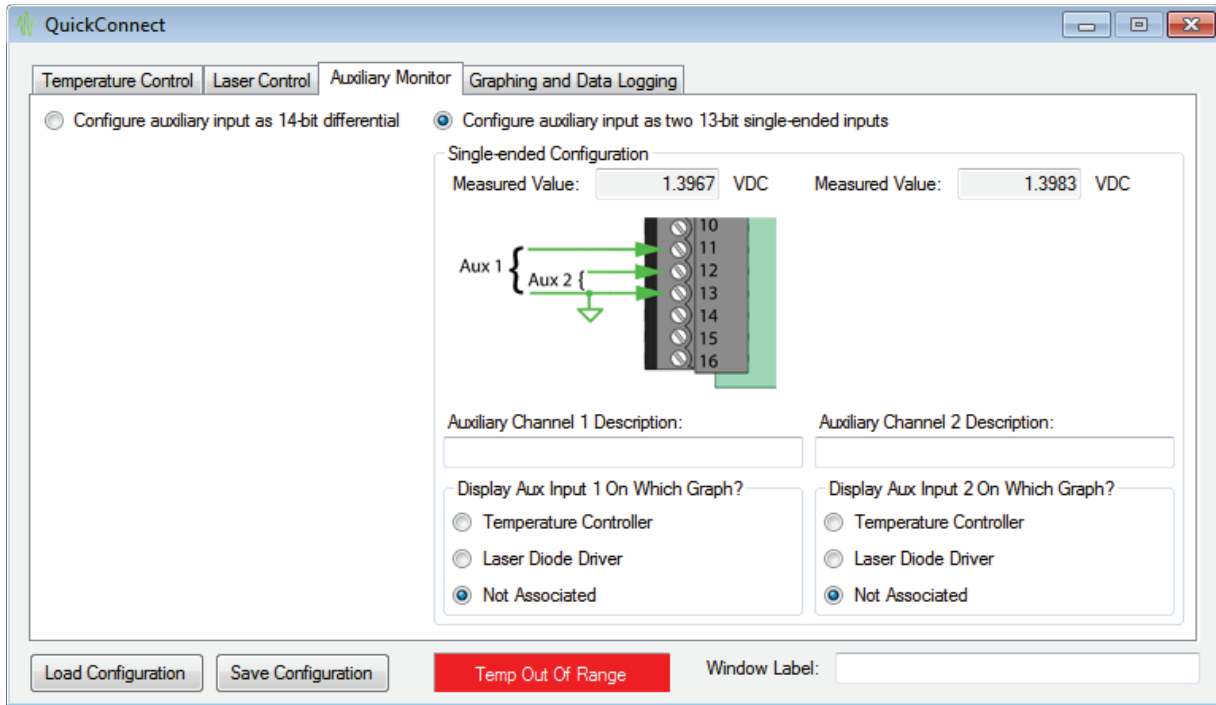

Figure 13. Auxiliary Monitor Configuration, Showing Two Single-Ended Inputs

Wiring two single-ended inputs (**Figure 13**) results in two 13-bit A/D channels, referenced to ground on pin 13.

Differentially wiring the inputs to pins 11 and 12 (shown in **Figure 14**) configures a single 14-bit A/D input channel. Neither pin is connected to ground, so the differential input is completely isolated.

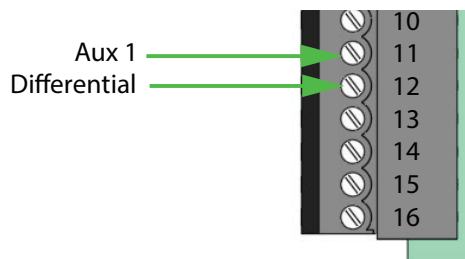

Figure 14. One Differential Auxiliary Input

The data from the auxiliary inputs is displayed directly as a voltage value between 0 and 5 V, and can be associated with either the laser driver or temperature controller. Once associated, the data can be graphed; refer to **page 16** for details on the graphing functions.

GRAPHING AND DATA LOGGING

Two graphs can be configured to plot data over time, shown in **Figure 15**. The top graph is associated with data from the Temperature Control tab, while the bottom graph is associated with data from the Laser Control tab.

The data availability is dependent on the model of temperature controller and laser driver that are selected, and may not appear exactly as shown here.

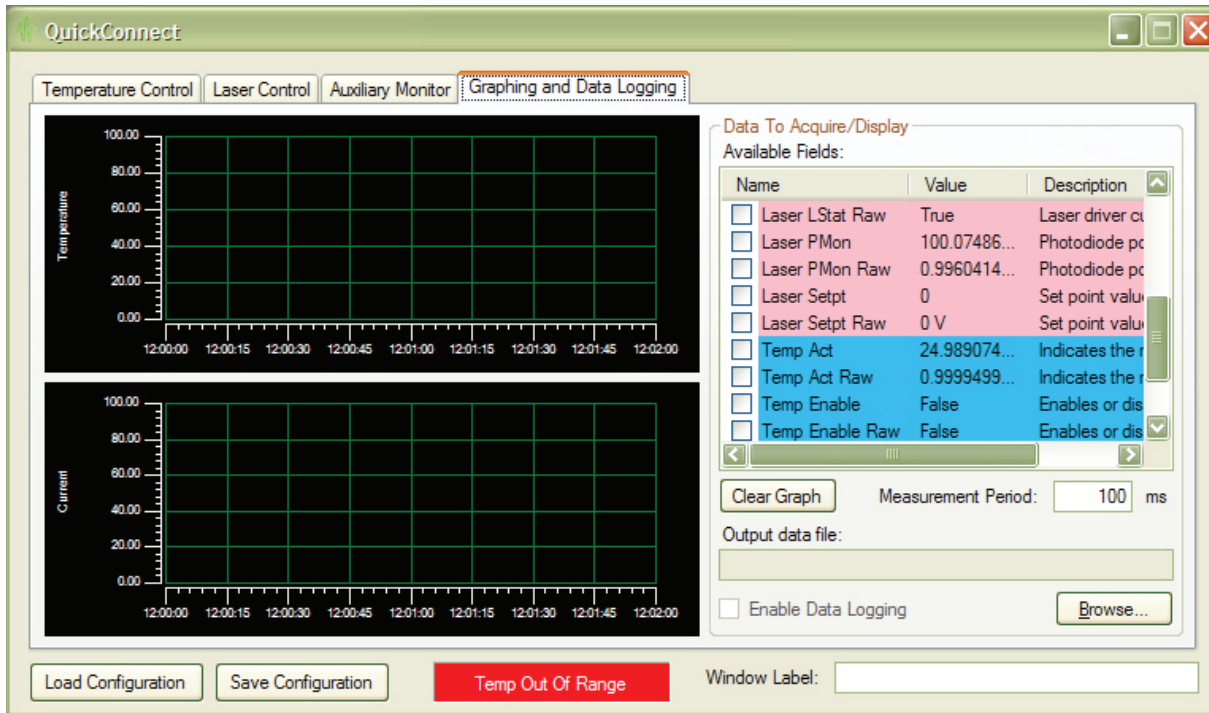

Figure 15. Graph Configuration and Display

Configure the Graphs

Check the box next to the data field Name to display it on the graph. Raw voltages can be displayed, or, in cases where a transfer function is applied in the software, the converted data value can be graphed. The vertical scale automatically adjusts depending on the input voltage values.

Pressing the Clear Graph button clears all the checked boxes for both graphs.

The Measurement Period determines how frequently data is acquired from the USBKIT. Minimum is 100 msec; maximum is 10 seconds; default is 100 msec. The measurement period also determines how frequently data is queried from the USBKIT; therefore the measurement period determines how quickly the software will respond to an error condition on the laser driver or temperature controller.

To change the display range of the graph from the two-minute default window, right-click on the x-axis label and choose EDIT. Click the Scale Range tab. Click the Span button labeled "...". Specify the desired time window to display.

Note that this may destabilize the system if too much data is stored in memory. To reduce the amount of data in memory, store data every minute instead of every 100 msec.

Data Logging

- Click Browse to specify the output data path and file name.
- Check Enable Data Logging to write to the data file.
- Data will be written to the file until the Enable Data Logging box is unchecked.
- File format is a tab-delimited text file. The first column is always date and time in OLE Date/Time format.

LICENSE AGREEMENT

The USBKIT QuickConnect™ Application is copyrighted by Wavelength Electronics Inc.

By purchasing the USBKIT from Wavelength Electronics the user has not purchased, nor do they own, the QuickConnect™ software or any of its components, but is granted permission to freely install the software on as many computers as are required for use with the Wavelength Electronics USBKIT product. Decompiling, disassembling or reverse engineering this software by any other means is expressly forbidden. The user is NOT granted a license to reuse subsets of the technology (e.g. modules or components of this application) in any other custom application without the express, written permission of Wavelength Electronics Inc. The QuickConnect™ application and its components and modules may not be redistributed by the user except when distributed with the USBKIT hardware from Wavelength Electronics, and may not be rebranded or resold under any other name. Wavelength Electronics makes no claims as to the fitness of this software for use in any specific application.

The user is subject to the end user license agreements for software components from National Instruments for the NI-DAQmx and NI-MAX software components, and to the end user license agreement from Microsoft Corporation for the installation of the .NET 4.0 framework.

This software is provided “as-is” by Wavelength Electronics for use with the USBKIT hardware and Wavelength Electronics’ temperature controller and laser driver modules.

ADDITIONAL TECHNICAL INFORMATION

GROUNDING USB PERIPHERALS

USB standards are designed for consumer electronics and can cause unexpected problems with electronic test equipment. The reason is that *the device connected to the computer must share the computer's ground connection via the USB cable and electronics.*

Consider the optical table configuration in **Figure 16**, with a PC controlling a laser diode driver. The laser anode is case-grounded, the laser case is electrically connected to the bench, the power supply is floating from ground, and the table top is earth grounded. This is a common optics lab configuration, and since the power supply is floating all appears to be fine.

But there are two serious hidden problems, and they'll become evident at the instant the USB cable connection is made.

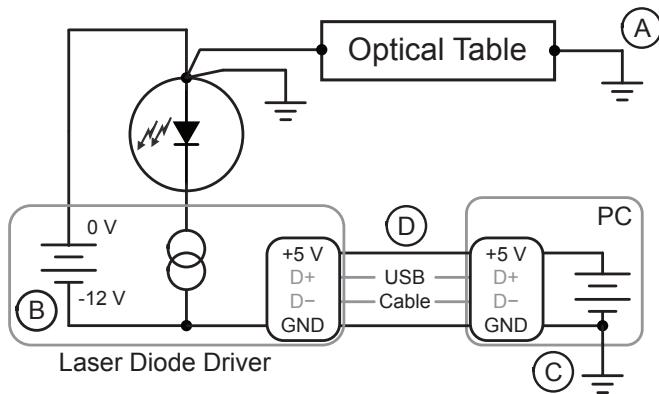

Figure 16. Test Bench with USB Control

The USB connectors are designed so that the +5V and GND connections are made before the data connections. But in the real world, the individual +5V and GND pins connect at very slightly different times—usually just a few milliseconds apart—and two different outcomes are possible:

- If the GND connection is made first, then both terminals of the laser power supply become connected to earth ground (Point A to C, through Point B). Either the power supply will blow a fuse, or the USB electronics will be damaged.
- If the +5V connection is made first, then the USB circuit in the laser driver is subjected to an over-voltage condition. The moment before connection, Point B is -12 V relative to earth ground and Point D is +5 V relative to earth ground. When the +5V connection is made there is an instantaneous 17 V differential across the USB controller. The electronics are designed for a 5 V environment, and 17 V will cause damage.

The simplest solution to this problem is to electrically isolate the laser anode from earth ground. Either the optical table has to be electrically floated, or the laser case must be electrically isolated from the table.

Another solution is to break the laser driver-to-earth ground connection along the USB system using a USB bus isolator. These devices employ opto-isolators in the data lines, and break the +5V and GND connections. With a USB isolator, the laser anode can be safely connected to the earth-grounded optical bench.



THE USBKIT IS **NOT** DESIGNED TO FUNCTION AS A USB ISOLATOR.

Two additional benefits of USB isolators: one potential inadvertent ground loop path is eliminated; and the notoriously noisy computer circuits are isolated from the laser control electronics.

Check the datasheet for your laser diode carefully to determine if the laser, TEC, or thermistor is connected to the case. If any internal components of the laser package are case grounded then follow the special precautions advised in this section.



NEVER ELIMINATE THE EARTH-GROUND CONNECTION OF THE COMPUTER. ISOLATING THE COMPUTER FROM EARTH GROUND IS EXTREMELY DANGEROUS AND CAN RESULT IN DAMAGE, FIRES, OR POTENTIALLY LETHAL ELECTRICAL CONDITIONS.

CUSTOM C OR LABVIEW PROGRAMMING

To develop your own C or LabVIEW program for the USBKIT hardware, download and install the NI-DAQmx device drivers from

www.teamwavelength.com/download/software/NIDAQ1600f0.zip.

A LabVIEW program also requires the LabVIEW Run-Time Environment (RTE):

<http://joule.ni.com/nidu/cds/view/p/id/3663/lang/en>.

Assign your own analog inputs and outputs and their associated transfer functions.

WIRING DIAGRAMS (LDTC0520 & LDTC1020 MODELS)

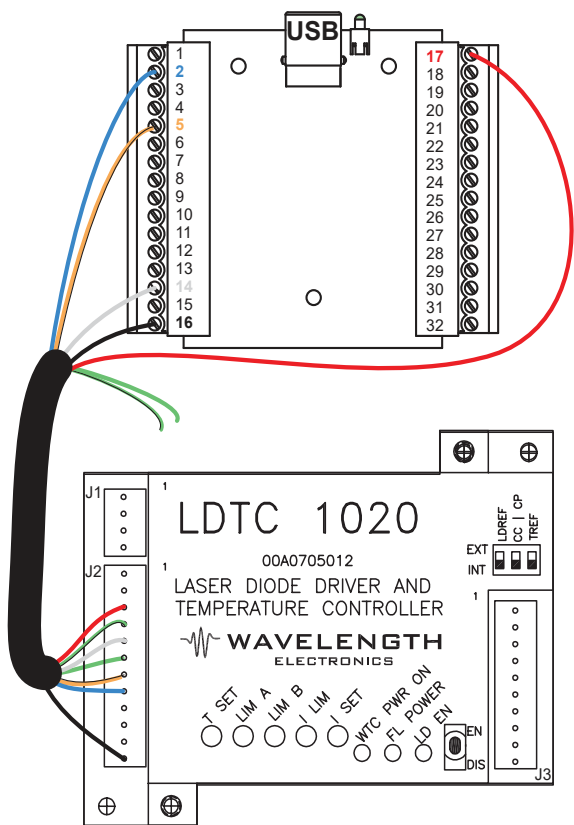

LDTc PIN	WIRE COLOR	USB ADD-ON PIN
1 - NC		
2 - NC		
3 - LD SHD	Red	17
4 - COMMON	Green & Black	Not Used
5 - EXT LD SET	White	14
6 - COMMON	Green	Not Used
7 - LD P M	Orange & Black	5
8 - LD I M	Blue	2
9 - ACT T M	Red & Black	Not Used
10 - SET T M	White & Black	Not Used
11 - EXT T SET	Orange	Not Used
12 - COMMON	Black	16

Figure 17. LDTC0520 & LDTC1020 (Laser Diode Driver)

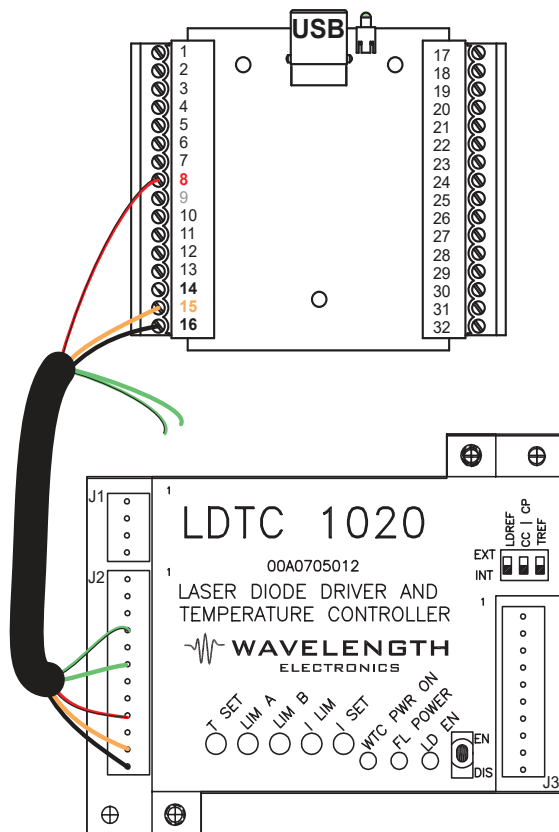

LDTc PIN	WIRE COLOR	USB ADD-ON PIN
1 - NC		
2 - NC		
3 - LD SHD	Red	Not Used
4 - COMMON	Green & Black	Not Used
5 - EXT LD SET	White	Not Used
6 - COMMON	Green	Not Used
7 - LD P M	Orange & Black	Not Used
8 - LD I M	Blue	Not Used
9 - ACT T M	Red & Black	8
10 - SET T M	White & Black	Not Used
11 - EXT T SET	Orange	15
12 - COMMON	Black	16

Figure 18. LDTC0520 & LDTC1020 (Temperature Controller)

WIRING DIAGRAMS (LDT C2/2 MODELS)

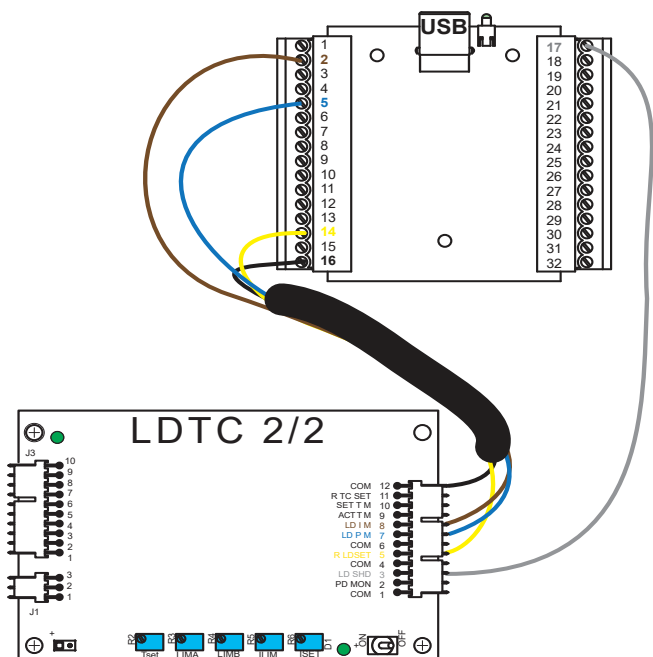

LDT C PIN	WIRE COLOR	USB ADD-ON PIN
1 - NC		
2 - PD MON	Not Used	Not Used
3 - LD SHD	Grey	17
4 - COMMON	Not Used	Not Used
5 - R LDSET	Yellow	14
6 - COMMON	Not Used	Not Used
7 - LD P M	Blue	5
8 - LD I M	Brown	2
9 - ACT T M	Not Used	Not Used
10 - SET T M	Not Used	Not Used
11 - R TC SET	Not Used	Not Used
12 - COMMON	Black	16

Figure 19. LDT C2/2 (Laser Diode Driver)

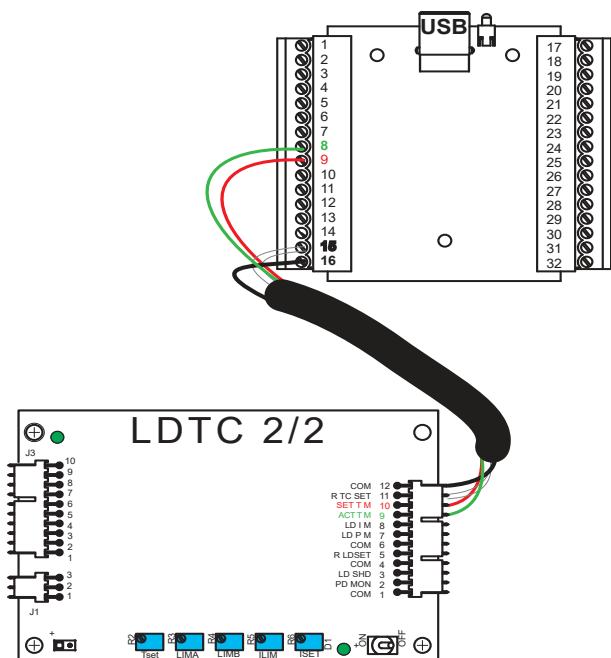

LDT C PIN	WIRE COLOR	USB ADD-ON PIN
1 - NC		
2 - PD MON	Not Used	Not Used
3 - LD SHD	Not Used	Not Used
4 - COMMON	Not Used	Not Used
5 - R LDSET	Not Used	Not Used
6 - COMMON	Not Used	Not Used
7 - LD P M	Not Used	Not Used
8 - LD I M	Not Used	Not Used
9 - ACT T M	Green	8
10 - SET T M	Red	9
11 - R TC SET	White	15
12 - COMMON	Black	16

Figure 20. LDT C2/2 (Temperature Controller)

WIRING DIAGRAMS (PLD PCB MODELS)

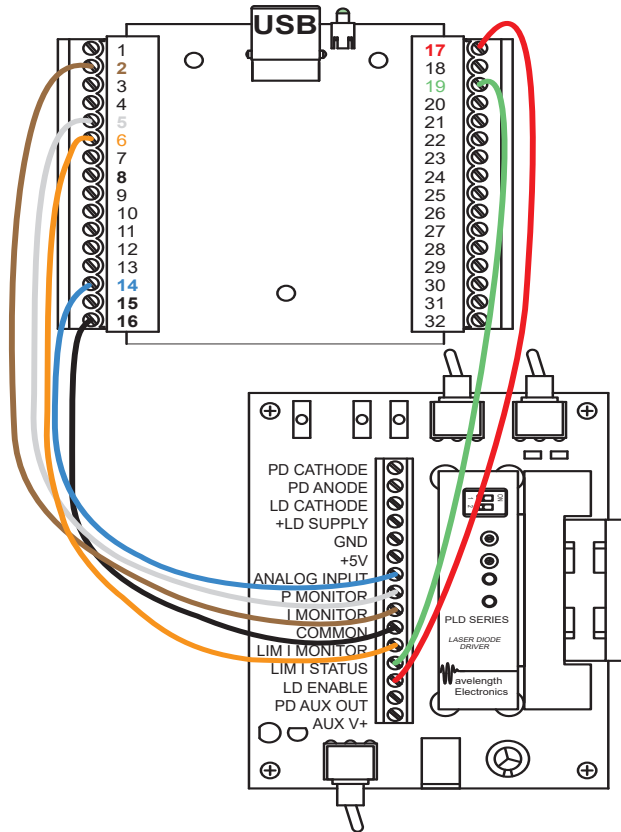

PLDEVALPCB PIN	USB ADD-ON PIN
PD CATHODE	
PD ANODE	
LD CATHODE	
+LD SUPPLY	
GND	
+5V	
ANALOG INPUT	14
P MONITOR	5
I MONITOR	2
COMMON	16
LIM I MONITOR	6
LIM I STATUS	19
LD ENABLE	17
PD AUX OUT	
AUX V+	

Figure 21. PLD5000

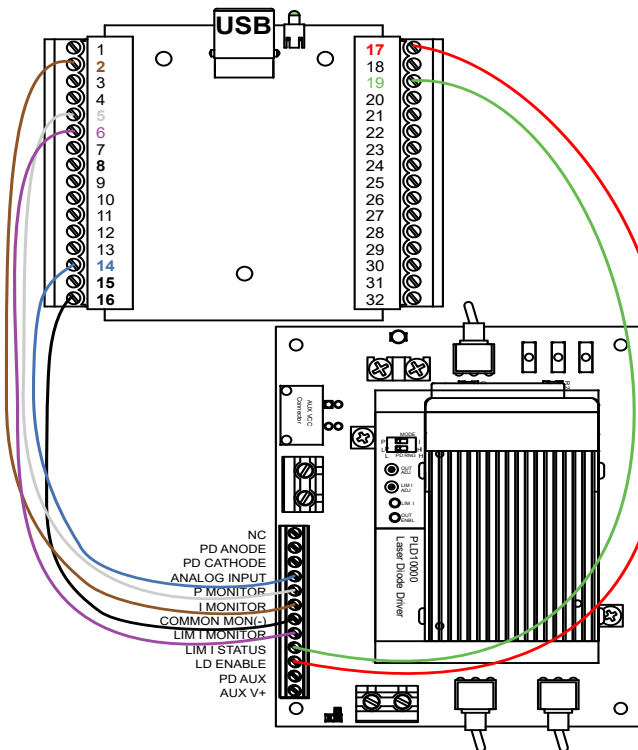

PLD10EV PIN	USB ADD-ON PIN
1 - NC	
2 - PD ANODE	
3 - PD CATHODE	
4 - ANALOG INPUT	14
5 - P MONITOR	5
6 - I MONITOR	2
7 - COMMON MON(-)	16
8 - LIM I MONITOR	6
9 - LIM I STATUS	19
10 - LD ENABLE	17
11 - PD AUX OUT	
12 - AUX V+	

Figure 22. PLD10000

WIRING DIAGRAMS (PLD CHASSIS MOUNT MODELS)

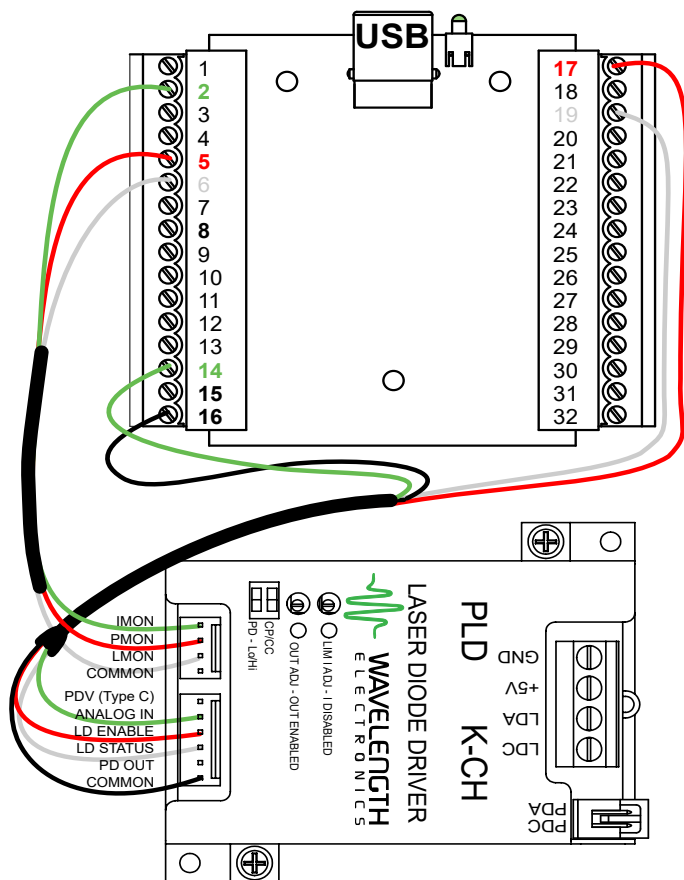

Wiring shown is for type A/B lasers

PLDK-CH PIN	WIRE COLOR	USB PIN
J2		
1 - COMMON	BLACK	No Connect
2 - LMON Limit Current Monitor	WHITE	6
3 - PMON Photodiode Current Monitor	RED	5
4 - IMON Current Monitor	GREEN	2
J3		
1 - COMMON	BLACK	16
2 - PD OUT (Type C) Photodiode Output	ORANGE	No Connect
3 - LD STATUS Enabled Status	WHITE	19
4 - LD ENABLE Output Enable	RED	17
5 - ANALOG IN Modulation Input	GREEN	14
6 - PDV (Type C) Photodiode Voltage	BLUE	No Connect

Figure 23. PLD-CH Series

WIRING DIAGRAMS (PTC MODELS)

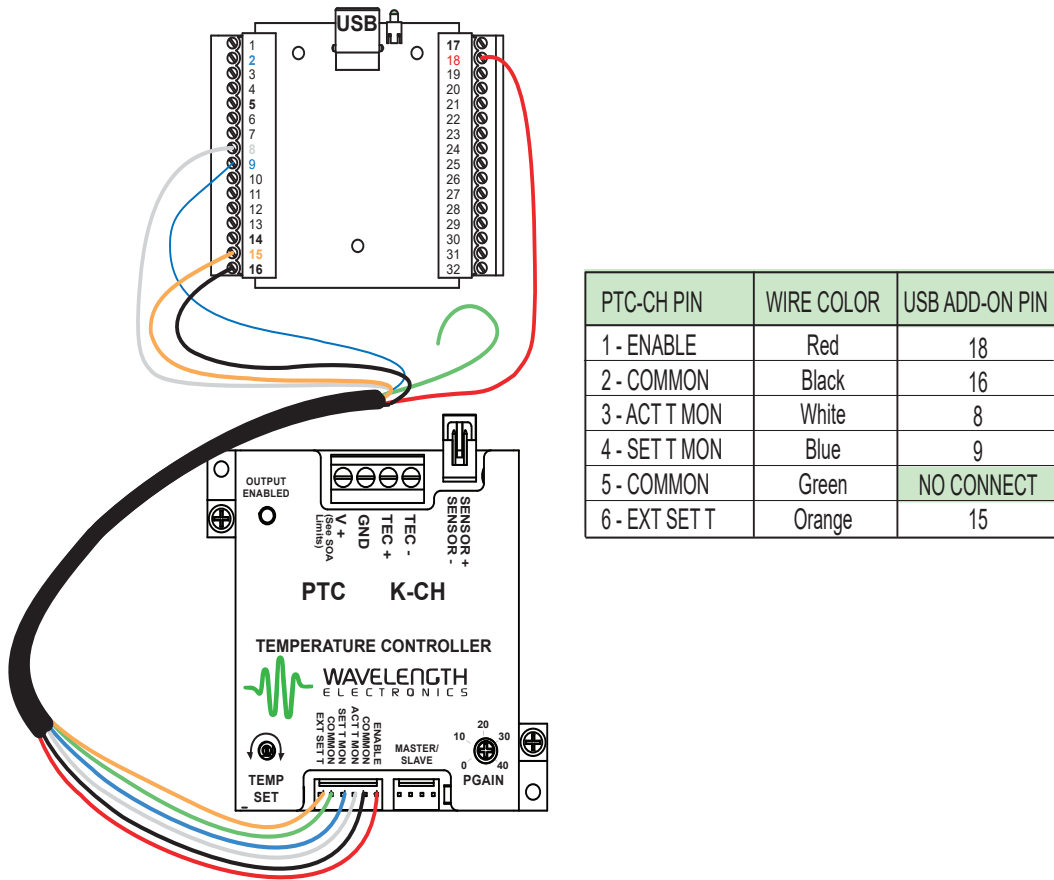

Figure 24. PTC-CH Series

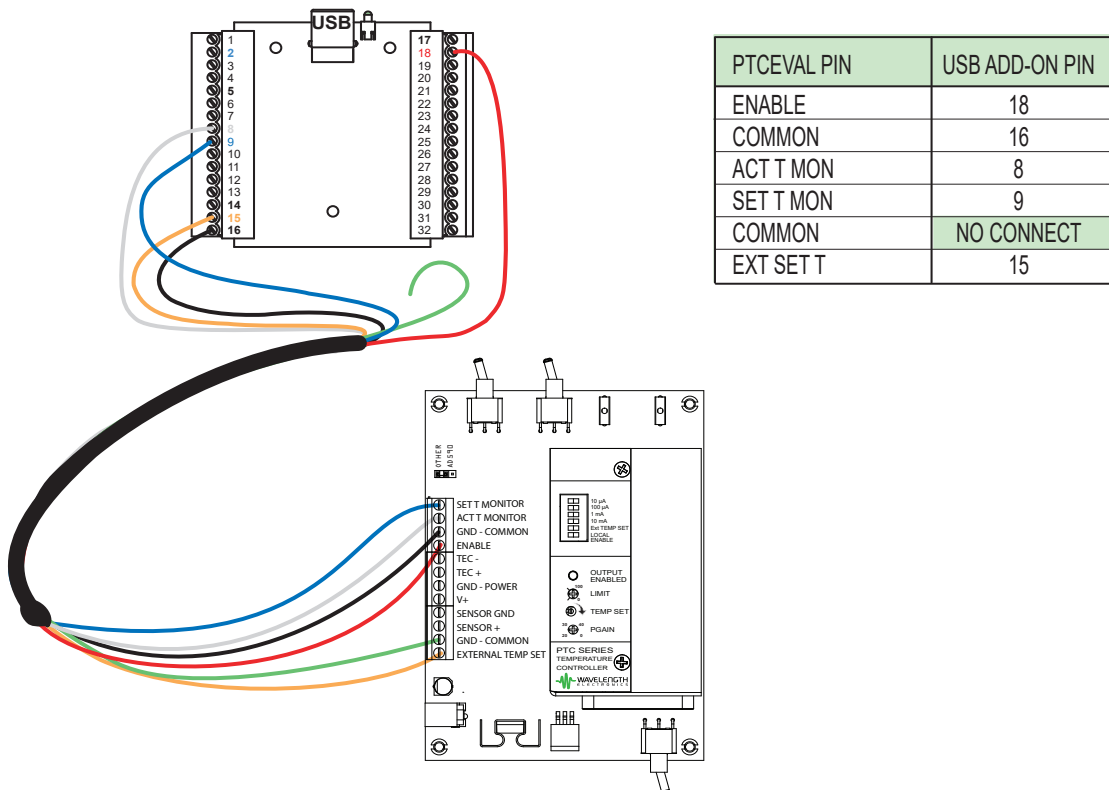

Figure 25. PTC PCB Mount Series

TROUBLESHOOTING

PROBLEM	POTENTIAL CAUSES	SOLUTIONS
Laser Driver or Temperature Controller output does not enable when the Enable button is selected in the software	Improperly configured hardware	Verify that the hardware is configured to accept the Enable signal from an external source. Refer to the datasheet and operating guide for the hardware that is connected to the USBKIT.
	Improperly configured software	Verify that the software is configured to send the external Enable signals for the hardware. Refer to page 10 for instructions on configuring the software for temperature controller operation; refer to page 14 for instructions regarding laser drivers.
Temperature control is grossly inaccurate	Improper sensor selected	Verify that the sensor type selected in the Hardware Status section matches the sensor that is being used.
	Improper temperature sensor profile / calibration	Verify the sensor calibration constants entered in the software are suitable for the sensor being used. Refer to the instructions for editing the Temperature Sensor Profiles from page 11 to page 13 .
	Sensor bias current mismatch between the software and the hardware	The Bias Current value entered in the temperature sensor profile must match the hardware configuration in order for the software to correctly convert the sensor voltage signal to a temperature value.
DAQ does not show up in Open Device window.	Incorrect version of NI-DAQmx or USBKIT	Make sure that the DAQmx version is 16.0.0 or later and the QCA version is 2.6.5 or later.

MECHANICAL SPECIFICATIONS

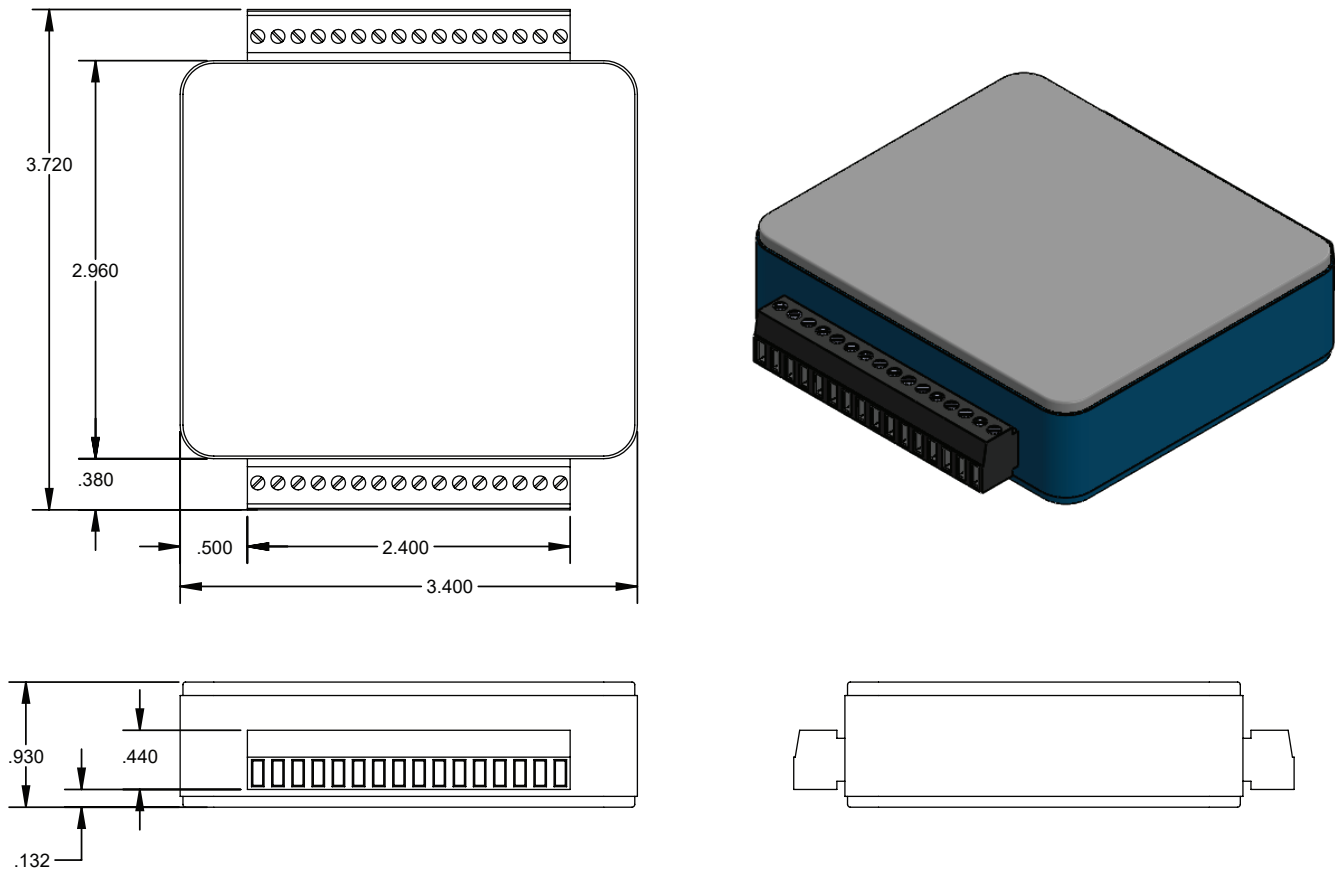

Figure 26. USBKit Mechanical Dimensions

All Tolerances $\pm 5\%$; units in inches [mm]

CERTIFICATION AND WARRANTY

CERTIFICATION

Wavelength Electronics, Inc. (Wavelength) certifies that this product met its published specifications at the time of shipment. Wavelength further certifies that its calibration measurements are traceable to the United States National Institute of Standards and Technology, to the extent allowed by that organization’s calibration facilities, and to the calibration facilities of other International Standards Organization members.

WARRANTY

This Wavelength product is warranted against defects in materials and workmanship for a period of 90 days from date of shipment. During the warranty period, Wavelength will, at its option, either repair or replace products which prove to be defective.

WARRANTY SERVICE

For warranty service or repair, this product must be returned to the factory. An RMA is required for products returned to Wavelength for warranty service. The Buyer shall prepay shipping charges to Wavelength and Wavelength shall pay shipping charges to return the product to the Buyer upon determination of defective materials or workmanship. However, the Buyer shall pay all shipping charges, duties, and taxes for products returned to Wavelength from another country.

LIMITATIONS OF WARRANTY

The warranty shall not apply to defects resulting from improper use or misuse of the product or operation outside published specifications. No other warranty is expressed or implied. Wavelength specifically disclaims the implied warranties of merchantability and fitness for a particular purpose.

EXCLUSIVE REMEDIES

The remedies provided herein are the Buyer’s sole and exclusive remedies. Wavelength shall not be liable for any direct, indirect, special, incidental, or consequential damages, whether based on contract, tort, or any other legal theory.

REVERSE ENGINEERING PROHIBITED

Buyer, End-User, or Third-Party Reseller are expressly prohibited from reverse engineering, decompiling, or disassembling this product.

NOTICE

The information contained in this document is subject to change without notice. Wavelength will not be liable for errors contained herein or for incidental or consequential damages in connection with the furnishing, performance, or use of this material. No part of this document may be translated to another language without the prior written consent of Wavelength.

SAFETY

There are no user-serviceable parts inside this product. Return the product to Wavelength Electronics for service and repair to ensure that safety features are maintained.

LIFE SUPPORT POLICY

This important safety information applies to all Wavelength electrical and electronic products and accessories:

As a general policy, Wavelength Electronics, Inc. does not recommend the use of any of its products in life support applications where the failure or malfunction of the Wavelength product can be reasonably expected to cause failure of the life support device or to significantly affect its safety or effectiveness. Wavelength will not knowingly sell its products for use in such applications unless it receives written assurances satisfactory to Wavelength that the risks of injury or damage have been minimized, the customer assumes all such risks, and there is no product liability for Wavelength. Examples of devices considered to be life support devices are neonatal oxygen analyzers, nerve stimulators (for any use), auto-transfusion devices, blood pumps, defibrillators, arrhythmia detectors and alarms, pacemakers, hemodialysis systems, peritoneal dialysis systems, ventilators of all types, and infusion pumps as well as other devices designated as “critical” by the FDA. The above are representative examples only and are not intended to be conclusive or exclusive of any other life support device.

REVISION HISTORY

DOCUMENT NUMBER: USBKIT-00400

REV.	DATE	CHANGE
E	July 2013	New software release
F	April 2016	Added wiring diagrams
G	January 2017	Updated NI DAQ requirements
H	April 2018	Updated for NI DAQ version 16.0.0 and QCA version 2.6.5

