

Thermoelectric Coolers

Total peltier module range – semi automated to highest efficiency

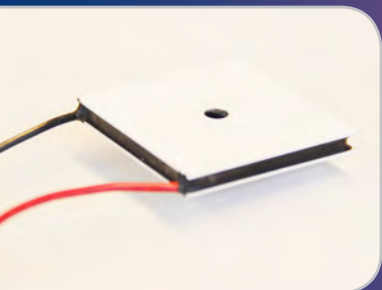

- ❄ Industrial electronics
- ❄ Research & Scientific
- ❄ Semiconductor equipment
- ❄ Laser equipment
- ❄ Medical equipment
- ❄ Transport
- ❄ Food industry





AMS Technologies is Europe's leading solution provider and distributor for Optical, Power and Thermal Management Technologies

WHERE TECHNOLOGIES MEET SOLUTIONS

For more than 30 years, we at AMS Technologies have been supporting the European market with leading, innovative technologies and products that have allowed our customers to take prime position in their chosen markets.

AMS Technologies is a leading solution provider and distributor of high-tech, leading-edge components, systems and equipment, with more than 30 years of experience to date and currently serving more than 2000 European customers.

We are the specialists in both componentry and complete solutions for Optical technology, Thermal Management and Power Technology fields, with access to and long standing relationships with the most advanced manufacturers in each of those fields. Drawing extensively on our experience in each of these differing technologies, and coupling this with our broad system-level competence, we are able to offer seamless and comprehensive solutions incorporating complementary aspects from all three key technology fields.

With an appropriate technical education, an element of entrepreneurial spirit and many years of design and consultancy expertise, our sales engineers can rapidly comprehend system requirements and provide you the customer with a solution that goes way beyond a simple understanding of our product datasheets. We take active involvement in the design cycle, defining and re-defining your specifications, and leading in many cases to highly specific, customized products and solutions. Helping you to effectively outsource your production line,

we can even provide you with the necessary leading turnkey contract manufacturing services in our key competency fields.

AMS Technologies has been delivering solutions into a variety of high-tech markets, including renewable energies, medical, defence & aerospace, research & scientific and various other industrial segments. Our customer base consists of Europe's largest leading technology corporations, a network of universities and research institutes as well as the most promising start-ups.

We thrive by working in a 'customer first' environment. Our pan-European customers are serviced from a network of local offices in Germany, the UK, France, Italy, Spain, Poland and Sweden, with a focused operations and logistics centre located in Munich, Germany.

Our commitment: Identifying the best solution for your project enabling you to become your customers' first choice!

Your AMS Technologies team



- Optical Technologies
- Power Technologies
- Thermal Management

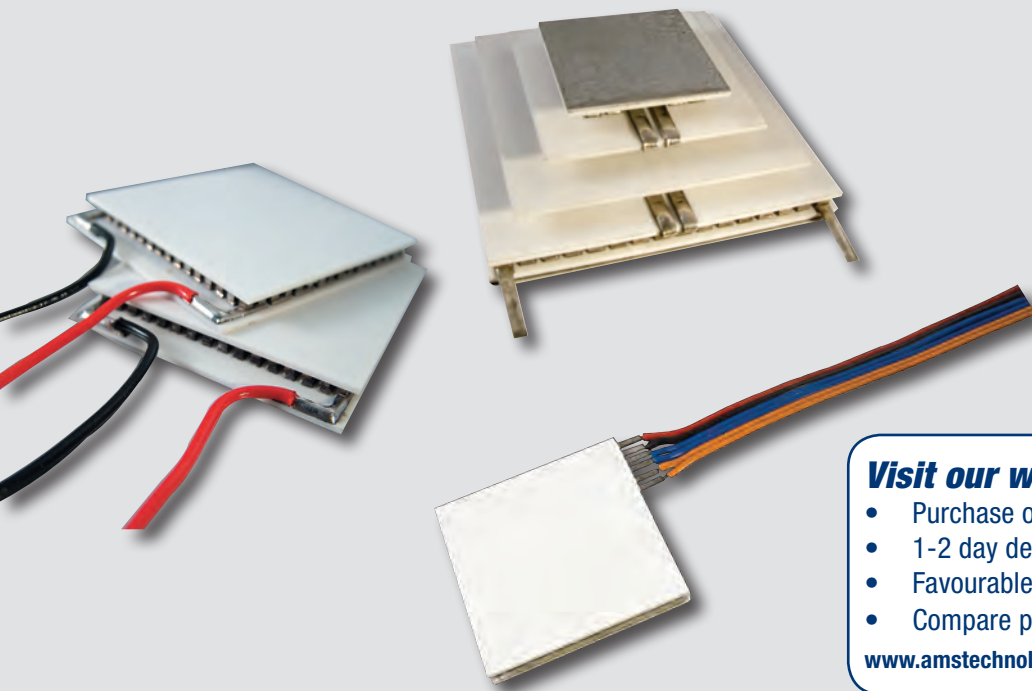

Contact us 

Visit our web shop!

- Purchase on account
- 1-2 day delivery
- Favourable shipping costs
- Compare products



www.amstechnologies-webshop.com/PeltierCoolers

THERMOELECTRIC TECHNOLOGIES

Thermoelectric cooling (TEC) uses the Peltier effect to create a thermal flux between the junction of two different types of materials.

The Peltier effect is used in a thermoelectric module for cooling and its opposite, the Seebeck effect, for power generation. Thermoelectric systems require careful design, proper selection of components and special skills for assembly. We partner with companies with decades of expertise in thermoelectricity and that are constantly refining the material compositions, the semi-automated production of their highest quality modules as well as the assembly and finishing of complete units.

AMS Technologies provides extensive development services for medical equipment, instrumentation, automotive and other applications. We also offer a complete thermoelectric solutions portfolio, including design consultancy and all components for thermoelectric modules, heat sinks, temperature controllers, assemblies air-to-air, plate-to-air, liquid-to-air and others. Furthermore, thermoelectric recirculating chillers are available with extraordinarily high efficiency and quiet operation.

The pickaTEC program

AMS Technologies has invested into the pickaTEC program offering customers off the shelf availability of a large number of different standard TECs. These preferred TECs should serve for proof of concepts, fast turnaround design ins and smaller volume batches.



The selection guide to these preferred TECs can be found on the next 2 pages. For large volume applications we recommend to call your regional AMS Technologies office, so that we can tailor a solution based on your technical needs.

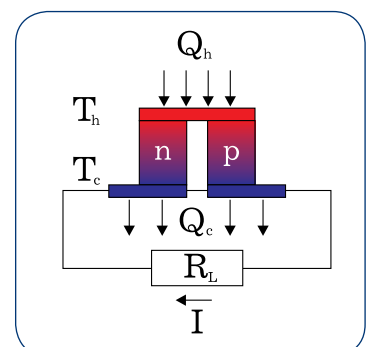
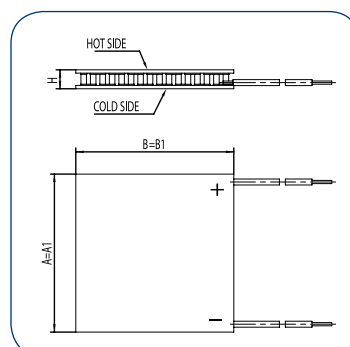
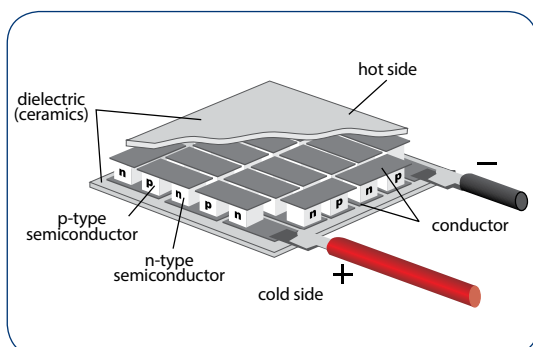

Standard Thermoelectric Coolers

Part number	I _{max} (A)	Q _{max} (W)	U _{max} (V)	dT _{max} (K)	R _{ac} (Ohm)
AMS-127-1.0-2.5 (30x30) HT120 E L2 70K	1.9	18.3	15.9	70	6.2
AMS-127-1.0-2.0 (30x30) HT120 E L2 70K	2.3	22.9	15.9	70	4.85
AMS-2-(127-127)-1.3 (30x30) HT120 E 83K	2.8	16.1	15.4	83	4.7
AMS-127-1.0-1.5 (30x30) HT120 E L2 69K	3.1	29.9	15.7	69	3.65
AMS-71-1.0-1.5 (23x23) HT120 E L2 69K	3.1	16.7	8.8	69	2.05
AMS-127-1.0-1.3 (30x30) HT120 E L2 71K	3.6	36	16.1	71	3.2
AMS-127-1.0-1.3 (30x30) HT120 E L2 69K	3.6	34.5	15.7	69	3.2
AMS-119-1.0-1.3CH (30x30) HT120 E L2 69K	3.6	32.3	14.7	69	3.1
AMS-83-1.0-1.3 (22x19) HT120 E L2 69K -CL	3.6	22.5	10.3	69	2.2
AMS-63-1.0-1.3 (15x30) HT120 E L2 69K -CS	3.6	17.1	7.8	69	1.6
AMS-31-1.0-1.3 (15x15) HT120 E L2 69K	3.6	8.4	3.8	69	0.8
AMS-17-1.0-1.3 (11.5x11.5) HT120 E L2 69K	3.6	4.6	2.1	69	0.42
AMS-127-1.4-2.5 (40x40) HT120 E L2 72K	3.7	37.4	16.3	72	3.2
AMS-125-1.4-2.5CH (40x40) HT120 E L2 72K	3.7	36.8	16	72	3.1
AMS-71-1.4-2.5 (30x30) HT120 E L2 72K	3.7	20.9	9.1	72	1.8
AMS-127-1.4-2.5 (40x40) HT120 E L2 74K	3.8	38	16.7	74	3.3
AMS-199-1.4-2.0 (40x40) HT120 E L2 70K	4.5	69	24.9	70	4
AMS-195-1.0-0.8 (25x50) HT120 E L2 68K -CL	5.8	86	24.1	68	3.2
AMS-127-1.0-0.8 (30x30) HT120 E L2 69K	5.8	56	15.7	69	2.05
AMS-38-1.0-0.8CHR (24D) HT120 E L2 69K	5.8	16.8	4.7	69	0.64
AMS-199-1.4-1.5 (40x40) HT120 E L2 70K	6.1	94	24.9	70	3.2
AMS-109-1.4-1.5CH (40x40) HT120 E L2 70K	6.1	51	13.7	70	1.8
AMS-71-1.4-1.5 (30x30) HT120 E L2 70k	6.1	33.4	8.9	70	1.17
AMS-127-1.4-1.5 (40x40) HT120 E L2 72K	6.2	62	16.3	72	2.05
AMS-127-1.4-1.5 (40x40) HT120 E L2 74K	6.3	65	16.7	74	2.05
AMS-71-1.2-1 (22x22) HT120 E L2 72K	6.9	38.2	8.9	72	0.99
AMS-127-2.0-2.5 (48x48) HT120 E L2 72K	7.6	76	16.3	72	1.65
AMS-127-2.0-2.5 (62x62) HT120 E L1 72K	7.6	76	16.3	72	1.65
AMS-31-2.0-2.5 (30x30) HT120 E L2 72K	7.6	18.7	4	72	0.4
AMS-199-1.4-1.15 (40x40) HT120 E L2 69K	7.9	120	24.6	69	2.4
AMS-127-1.4-1.15 (40x40) HT120 E L2 69K	7.9	76	15.7	69	1.5
AMS-125-1.4-1.15CH (40x40) HT120 E L2 69K	7.9	75	15.5	69	1.5
AMS-71-1.4-1.15 (30x30) HT120 E L2 69K	7.9	43	8.8	69	0.8
AMS-127-1.4-1.15 (40x40) HT120 E L2 71K	8	80	16.1	71	1.5
AMS-127-1.4-1.05 (40x40) HT120 E L2 69K	8.6	84	15.7	69	1.4
AMS-99-1.4-1.05 (40x20) HT120 E L2 69K -CL	8.6	65	12.3	69	1.07
AMS-241-1.7-1.5 (40x40) HT120 E L2 94K	10.8	84.1	21.1	94	1.54
AMS-199-1.4-0.8 (40x40) HT120 E L2 69K	11.3	172	24.6	69	1.65
AMS-99-1.4-0.8 (40x20) HT120 E L2 69K -CL	11.3	86	12.3	69	0.8
AMS-127-2.0-1.5 (48x48) HT120 E L2 70K	12.4	122	15.9	70	0.95
AMS-199-1.4-0.6 (40x40) HT120 E L2 68K	15.1	229	24.6	68	1.25
AMS-71-1.2-0.25 (22x22) HT120 E L2 76K	28.4	166.7	9.38	76	0.25

dT_{max} maximum achievable temperature difference between the hot and cold side of a thermoelectric cooler

I_{max} input current through thermoelectric cooler resulting in greatest DT (DT_{max})

U_{max} voltage on a thermoelectric cooler contacts at DT_{max}

Q_{max} maximum cooling capacity of thermoelectric cooler. It is determined at maximum current through a thermoelectric cooler and at zero temperature difference between hot and cold sides

R_{ac} electric resistance of the thermoelectric cooler measured at an alternating current with the frequency of 1 kHz

A (mm)	B (mm)	H (mm)	Diameter Round TEC (mm)	Diameter Hole (mm)	Supplier item number
30	30	4.8			TB-127-1.0-2.5
30	30	4.3			TB-127-1.0-2.0
30	30	8.8			TB-2-(127-127)-1.3
30	30	3.8			TB-127-1.0-1.5
23	23	3.8			TB-71-1.0-1.5
30	30	3.6			Snowball-71
30	30	3.6			TB-127-1.0-1.3
30	30	3.6		4	TB-119-1.0-1.3 CH
22	19	3.6			TB-83-1.0-1.3
15	30	3.6			TB-63-1.0-1.3
15	15	3.6			TB-31-1.0-1.3
11.5	11.5	3.6			TB-17-1.0-1.3
40	40	4.8			TB-127-1.4-2.5
40	40	4.9		4.7	TB-125-1.4-2.5 CH
30	30	4.9			TB-71-1.4-2.5
40	40	4.8			RIME-74
40	40	4.4			DRIFT-2.0
50	25	3.1			TB-195-1.0-0.8
30	30	3.1			TB-127-1.0-0.8
		3.1	24	9.8	TB-38-1.0-0.8 CHR
40	40	4.1			DRIFT-1.5
40	40	4		13	TB-109-1.4-1.5 CH
30	30	4			TB-71-1.4-1.5
40	40	3.9			Frost-72
40	40	3.9			Frost-74
22	22	1.7			
48	48	4.8			TB-127-2.0-2.5
62	62	4.8			TB-127-2.0-2.5
30	30	4.8			TB-31-2.0-2.5
40	40	3.6			DRIFT-1.15
40	40	3.6			TB-127-1.4-1.15
40	40	3.6		4.7	TB-125-1.4-1.15 CH
30	30	3.6			TB-71-1.4-1.15
40	40	3.4			ICE-71
40	40	3.3			TB-127-1.4-1.05
40	20	3.4			TB-99-1.4-1.05
40	40	3.0			CENTUM 240-11-01
40	40	3.2			DRIFT-0.8
40	20	3.2			TB-99-1.4-0.8
48	48	3.8			TB-127-2.0-1.5
40	40	3.1			DRIFT-0.6
22	22	1.0			

Contact us





ACCESSORIES

AMS Technologies provides a range of products suitable for your TEC design. Those include Heat sinks, Cold plates, TEC drivers and TEC controllers.

Cold plates

Our cold plate technologies range from tubed cold plates and flat tube cold plates to performance-fin cold plates and liquid-cooled chassis.

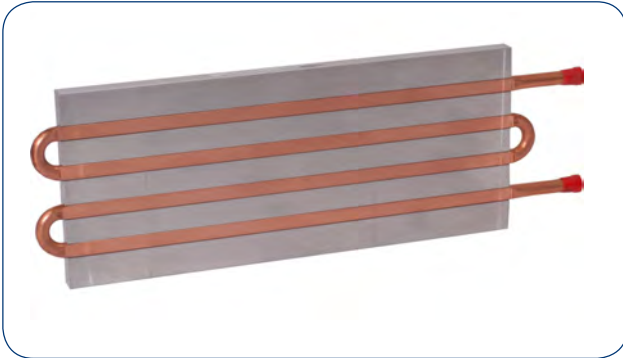

Heat sinks

Our heat sinks are designed to maximize its surface area in contact with the cooling medium surrounding it.



Temperature Controllers

AMS Technologies offers a range of high precision, ultra stable Temperature Controllers (TEC) for laser diode temperature control. Our TECs give you best thermal stability, plus the ability to adjust the laser temperature and thus change the laser output wavelength, laser drive current or modal stability.

Ultra-stable, high precision quantum cascade laser drivers, laser diode drivers and temperature controllers are available for a wide range of applications such as biomedical, imaging, spectroscopy, remote sensing, military, aerospace, communications, material processing, environmental and manufacturing control. Laser Diode Safety is paramount and protection is built into every module.

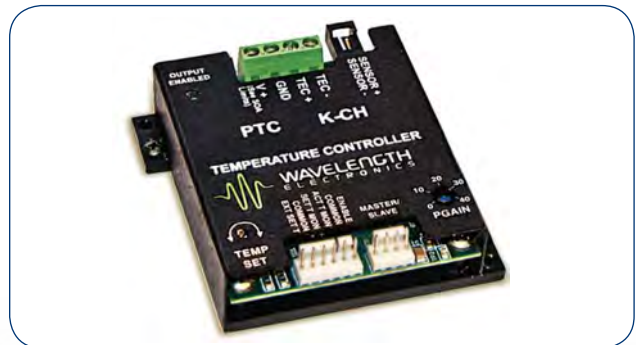

Visit our web shop!

- Purchase on account
- 1-2 day delivery
- Favourable shipping costs
- Compare products

www.amstechnologies-webshop.com/PeltierCoolers

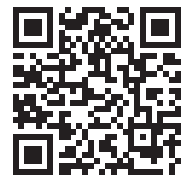

Contact us



Optical, Power and Thermal Management Technologies represent the biggest technological challenges facing any engineer.

OUR SOLUTION APPROACH

AMS Technologies' solution approach has helped hundreds of customer projects to move from concept to production. Helping you to understand our capabilities, we invite you to browse a list of the many projects that we have successfully completed over a timeframe closely approaching 30 years.

Our three key competencies Optical, Power and Thermal Management have no logical bits and bytes, nor industry qualification standards. Hence the design of a system and the choice of the right technology, supplier and products can only be based on knowledge and experience in those fields. AMS Technologies has built a comprehensive knowledge base in those three key competencies, enabling us to provide customers with complete solutions, over and above the mere product support for standard TECs we can provide.

- Development of customized specification sheets
- Effective project management of any product development
- Higher level design services for system-level prototypes
- Interdisciplinary system-level integrated design
- Appropriate subcontractor selection and production support
- Proper vetting of technologies and suppliers
- Simulations and modeling of system-level designs
- Installation, training and servicing

Thermal simulation with CFD

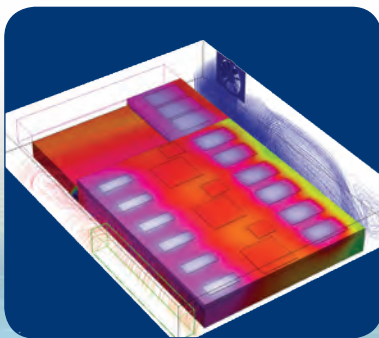

Thermal simulation with computational fluid dynamics (CFD) allows the engineer to dimension his system in great detail. Especially in complex systems life expectancy of electronic components, space, mass and cost may be

optimized. The analysis of temperatures and air flows helps to take the right measures such as adjusting air flow, positioning of power components, dimensioning of heat sinks and fans and others. AMS Technologies has done more than 230 studies for customers since the year 2000.

SOLUTION EXAMPLES

Thermocupholder



Understanding the energy balance was key to the thermoelectric cooling unit design that won the Audi contest for best performance. Insulation properties, current draw, heat reflux, heat sink geometry and air channels had to be balanced to achieve the optimum results.

Laser diode module cooling

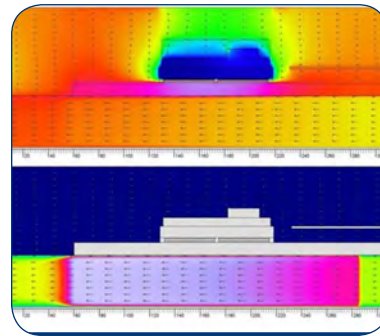

Safe operation at high ambient temperature required two peltier modules. Conventional high-performance heat sinks are not good in heat spreading and a high temperature difference creates a 300 W heat load on the hot side of a single peltier for a 60 W laser diode. The solution was to operate peltier modules in more efficient mode and distribute power on two modules.

Cosmetic cooling box



Small and flat to fit in the back of upright shoebox size cool box, relatively poor thermal insulation and quiet operation were main challenges for a thermoelectric cooling system for cosmetics. Energy balance showed that internal forced convection was necessary to achieve the temperature homogeneity of +/-1 K.

SOLUTIONS



enabling your ideas.

Optical, Power and Thermal Management Technologies

■ GERMANY

AMS Technologies AG
Fraunhoferstr. 22
82152 Martinsried, Germany
Phone + 49 (0) 89 895 77 0

■ ITALY

AMS Technologies S.r.l.
Via Copernico, 21
20025 Legnano (MI), Italy
Phone + 39 0331 596 693

■ SPAIN

AMS Technologies S.L.
C/Filadors 35, 3^o, 7^a
08208 Sabadell, Spain
Phone + 34 93 380 84 20

■ FRANCE

AMS Technologies S.A.R.L.
Silic 649 – Bâtiment Magnolia
16, avenue du Québec
91945 Courtaboeuf Cedex
Phone + 33 (0) 1 64 86 46 00

■ NORDICS

AMS Technologies Nordics
Azpect Photonics AB
Aminogatan 34
431 53 Mölndal, Sweden
Phone + 46 (0) 8 55 44 24 80

■ UNITED KINGDOM

AMS Technologies Ltd.
Nene House, Drayton Way
Daventry, Northamptonshire
NN11 8EA, United Kingdom
Phone + 44 (0)1455 556360

Download Brochure

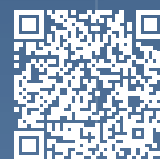

info@amstechnologies.com
www.amstechnologies.com
www.amstechnologies-webshop.com