

DATASHEET AND OPERATING GUIDE

QCL OEM Series

Low-Noise Quantum Cascade Laser Driver

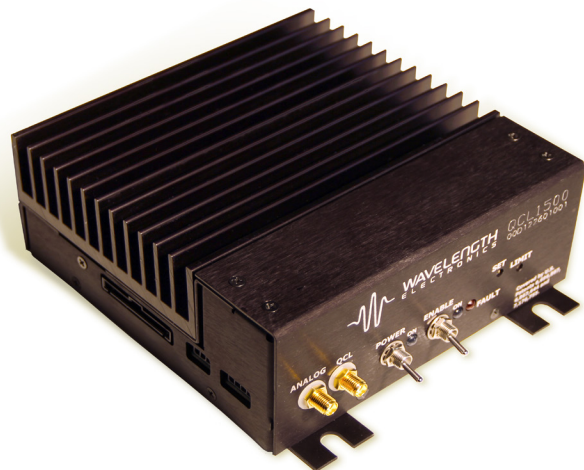

FEATURES AND BENEFITS

- Off-the-shelf models at 500 mA, 1 A, 1.5 A, 2 A
- Can be delivered in other current ranges up to 2 A
- Compliance voltage 16 V (standard), Compliance 7-20 V with factory modification
- Safety features protect your QCL investment
 - » Adjustable soft-clamping current limit
 - » Brown-out, reverse-voltage, & over-voltage protection
 - » Driver over-temperature protection circuit
 - » Relay shorts output when current is disabled
- Local and Remote Power-On and Enable control
- Analog modulation input between -5V and +5V

LOWEST-NOISE DRIVER AVAILABLE

The QCL OEM Series drivers use patented¹ circuitry to produce the lowest current noise density of any commercially available QCL driver. The 500 mA QCL driver exhibits noise performance of 0.4 μ A RMS to 100 kHz, and average current noise density of 1 nA / $\sqrt{\text{Hz}}$ —the lowest available.

ULTRA-NARROW QCL LINEWIDTH

In order to maintain their characteristically tight center linewidths and minimize jitter, quantum cascade lasers must be powered by drivers with exceptionally low current noise density. Our customers have reported achieving narrower linewidths with these drivers than any other they've used.

1. Covered by U.S. Patents 6,696,887; 6,867,644 and 7,176,755. Licensed from Battelle Memorial Institute.

APPLICATIONS

The QCL Series drivers are used in trace element detection systems, both laboratory-based and field-deployed. This driver is well suited to applications requiring fast measurement times and ultra high sensitivity.

REVERSE POLARITY AVAILABLE

Often, with epi-down configurations of a QCL, the exit lead is attached to the case and it is desirable to ground it. Now, the reverse polarity driver, a current source, is also available in the OEM package. See QCL OEM(+).

PROTECT YOUR QCL INVESTMENT

All the essential control and monitor functions you expect in a Wavelength laser driver are incorporated into this driver, along with protection circuitry to safeguard your QCL from minor power source faults, over-temperature conditions, and electrical faults.

CONTENTS

	PAGE
QUICK CONNECT GUIDE	2
PIN DESCRIPTIONS	3
ELECTRICAL SPECIFICATIONS	5
SAFETY INFORMATION	7
OPERATING INSTRUCTIONS	8
TROUBLESHOOTING	13
TECHNICAL SUPPORT INFORMATION	14
MECHANICAL SPECIFICATIONS	22
CERTIFICATION AND WARRANTY	23

ORDERING INFORMATION

PART NO	DESCRIPTION
QCL500 OEM	500 mA Low Noise QCL Driver
QCL1000 OEM	1.0 A Low Noise QCL Driver
QCL1500 OEM	1.5 A Low Noise QCL Driver
QCL2000 OEM	2.0 A Low Noise QCL Driver
QCL OEM(+)	Positive polarity OEM models
PWRPAK-24V	24 VDC switching power supply (2x required)
WCB312	Dual power supply wiring kit
NOISESCAN	Noise characterization scan
55-110014	SMA-BNC low noise cable
WCB310	SMA-SMA low noise cable
QCLTL Series	Test load kits for the QCL OEM

QUICK CONNECT GUIDE



TO ENSURE SAFE OPERATION OF THE QCL DRIVER, IT IS IMPERATIVE THAT YOU DETERMINE THAT THE UNIT WILL BE OPERATING WITHIN THE INTERNAL HEAT DISSIPATION SAFE OPERATING AREA (SOA).

Visit the Wavelength Electronics website for the most accurate, up-to-date, and easy to use SOA calculator:

<https://www.teamwavelength.com/support/design-tools/soa-ld-calculator/>

Figure 1 shows the front panel of the QCL OEM driver and the locations of the Power and Enable switches, Analog In and QCL SMA connectors, and SET and LIMIT trimpots.

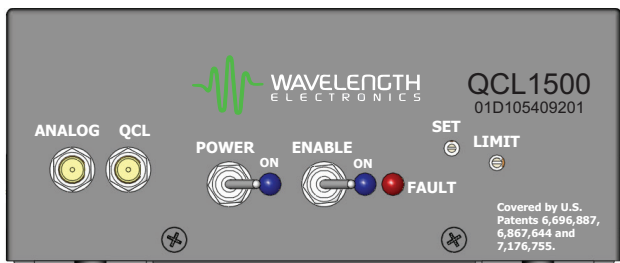

Figure 1. QCL Driver Front Panel

Figure 2 shows the wiring diagram for the QCL driver and external electronics. If you are using the Remote Power On and Remote Enable functions, refer to **page 11** for switch configuration instructions.

For setup and configuration, we recommend using a test load in place of the laser (**Figure 3**). Recommended test load for 0 to 1.5 A operation, $R_{LOAD} = 10 \Omega$, 50 W, metal film resistor:

- Wavelength part number QCL TEST LOAD (available for < 1 A and 1.5 A current ranges)
- Caddock MP850-10-1%
- Ohmite TCH35P10R0JE

Recommended test load for 1.5 A to 2 A operation, $R_{LOAD} = 5 \Omega$, 50 W, metal film resistor:

- Wavelength part number QCL TEST LOAD (available for 1.5 A, and 2 A current ranges)
- Caddock MP850-5.00-1%

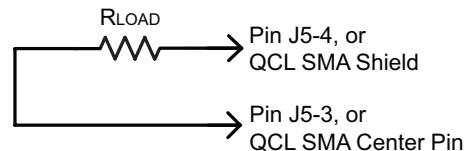
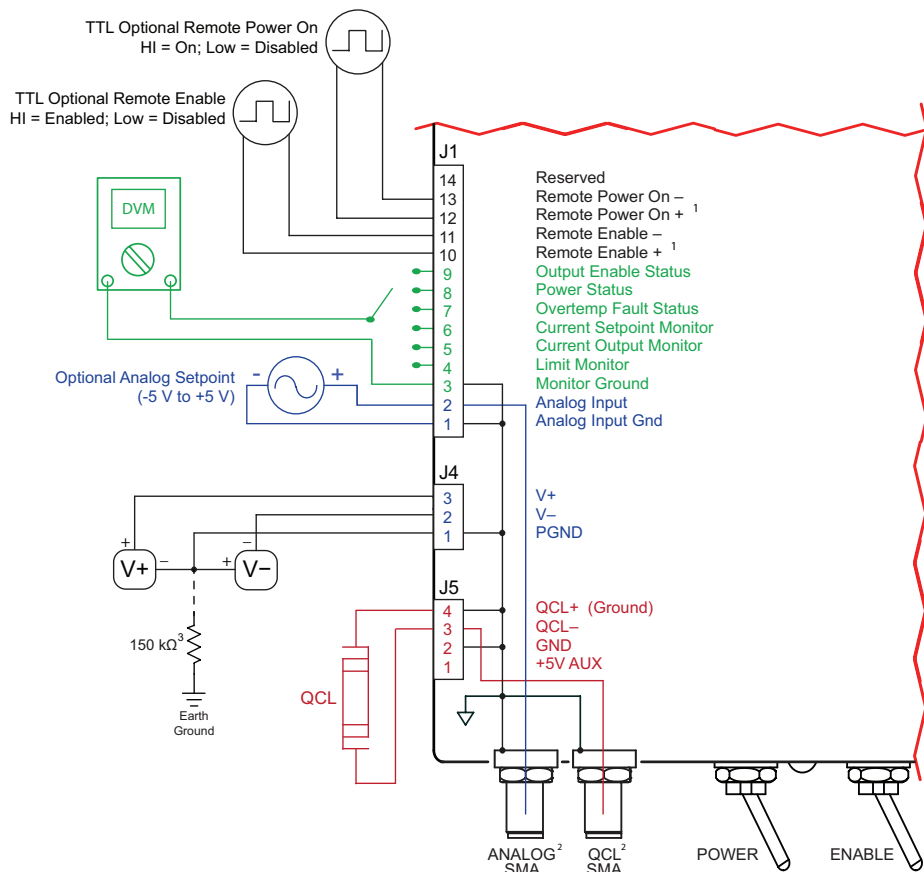

Figure 3. Test Load



NOTES

1. The Remote Power On - and Remote Enable - inputs can be optically isolated from ground.
2. The SMA connectors are electrically isolated from the QCL chassis.
3. The 150 kΩ resistor is required in some circumstances. Refer to the section on wiring the power supplies.

Figure 2. QCL Wiring Diagram, Revision D

PIN DESCRIPTIONS

Table 1. Pin Descriptions, WCB31X Cable Descriptions

PIN	NAME	SYMBOL	COLOR	PIN DESCRIPTION
Connector J1, WCB311 14-Pin Input/Output Cable				
1	Analog In GND		Red	Ground for analog setpoint input. Pin is not rated for high current return.
2	Analog In		Black	Analog setpoint input. The voltage input on this pin sums with the onboard setpoint trimpot. Input impedance 1 kΩ. Transfer function varies by model—refer to Table 3 . Damage threshold is ±10V.
3	Monitor Ground		Black	Low current ground used with monitor pins J1:4, 5, and 6. Also used as the current return path for status output pins J1:7, 8, and 9. This pin is not rated for high current.
4	Current Limit Monitor	LIM_MON	Red	Current limit monitor. Transfer function varies by model—refer to Table 3 . Range 0 to 5 V.
5	Current Output Monitor ¹	OUT_MON	Brown	Current output monitor. Transfer function varies by model—refer to Table 3 . Range 0 to 5 V on Revision D models. Refer to note 1 for range of previous instrument revisions.
6	Current Setpoint Monitor	SET_MON	White	Current setpoint monitor. Transfer function varies by model—refer to Table 3 . Range 0 to 5 V.
7	Overtemp Fault Status		Orange	Overtemp Fault = HI. Indicates internal components are above safe operating temperature and the output has switched off. Can drive an indicator LED, sourcing up to 25 mA at 12 V.
8	Power Status		Green	Power On = HI. Can drive an indicator LED, sourcing up to 25 mA at 12 V.
9	Output Enable Status		Blue	Output Enabled = HI. Can be used to drive an indicator LED, sourcing up to 25 mA at 12 V.
10	Remote Enable +		Red	Remote Output Enable signal. DISABLE = LO (< 3 V), ENABLE = HI (5 to 12 V). Toggle to reset a protection circuit fault.
11	Remote Enable –		Green	Return for Remote Enable signal. Can be optically isolated from the instrument ground; see page 11 .
12	Remote Power On +		White	Remote Power On signal. OFF = LO (< 3 V), ON = HI (5 to 12 V). Toggle to reset a protection circuit error.
13	Remote Power On –		Black	Return for Remote Power On signal. Can be optically isolated from the instrument ground; see page 11 .
14	Reserved		–	
Connector J4, WCB313 3-Pin QCL Power Cable				
1	PGND		Black	High current return, connect to power supplies.
2	V–		White	Negative DC power supply input. Typically –24 VDC. Other input voltage ranges can be used with product variations—contact Sales for information.
3	V+		Red	Positive DC power supply input. Typically 24 VDC. Other input voltage ranges can be used with product variations—contact Sales for information.
Connector J5, WCB314 4-Pin QCL Load Cable				
1	+5V AUX		Green	+5V power supply output. Use pin 2 of this connector for the return. Refer to page 10 for information on configuring this power supply output.
2	GND		White	Ground connection for +5V AUX. This pin is always connected to ground, regardless of the configuration state of the +5V AUX output.
3	QCL –		Red	Current from the QCL sinks to this pin. Refer to Figure 2 .
4	QCL + (GND)		Black	Ground connection. QCL current sources from this pin. Refer to Figure 2 .

1. Product revision is indicated by the third digit of the serial number engraved on the front panel. Refer to **page 14** for transfer functions for Revisions A through C.

PIN DESCRIPTIONS (CONTINUED)

Table 2. Front Panel SMA Connector Descriptions

FRONT-PANEL SMA CONNECTORS		
Left SMA, Center Pin	Analog In	Analog setpoint input. The voltage input on this pin sums with the onboard setpoint trimpot. Input impedance 1 kΩ. Transfer function varies by model—refer to Table 3 . The analog input voltage can be negative.
Left SMA, Shield	Analog In GND	Ground for analog setpoint input. Pin is not rated for high current return.
Right SMA, Center Pin	QCL –	Current from the QCL sinks to this pin. Refer to Figure 2 .
Right SMA, Shield	QCL + (Ground)	Ground connection. QCL current sources from this pin. Refer to Figure 2 .

Table 3. Current Limit Monitor and Setpoint Transfer Functions—Revision D*

FUNCTION	SYMBOL	QCL125	QCL500	QCL1000	QCL1500	QCL2000
Current Setpoint Monitor	SET_MON	0.025 A / V	0.1 A / V	0.2 A / V	0.3 A / V	0.4 A / V
Current Output Monitor	OUT_MON	0.025 A / V	0.1 A / V	0.2 A / V	0.3 A / V	0.4 A / V
Current Limit Monitor	LIM_MON	0.025 A / V	0.1 A / V	0.2 A / V	0.3 A / V	0.4 A / V
Analog Input	V _{ANALOG}	0.025 A / V	0.1 A / V	0.2 A / V	0.3 A / V	0.4 A / V

* For transfer function information on product revisions A – C, refer to **page 14**.

ELECTRICAL SPECIFICATIONS

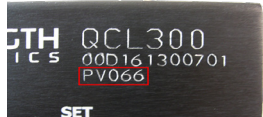
PARAMETER	SYMBOL	MIN	TYP	MAX	UNIT	NOTE			
ABSOLUTE MAXIMUM RATINGS									
Positive Supply Voltage ¹	V+	25			VDC	If a Product Variation modified your QCL OEM, maximum ratings change: 			
							PV #	MAX V	COMPLIANCE
							PV055	+24 / -28	+20
							PV066	±15	+7
						PV072	±19	+11	
Negative Supply Voltage ¹	V-	-25			VDC	The PV number can be found on the front panel below the model and lot numbers: 			
Internal Power Dissipation ²	P _{MAX}			16	W	@ 25°C, no air movement. Reference SOA charts			
Operating Temperature Range ²	T _{OPR}	-40 to 50			°C	35°C max for QCL2000 OEM			
Storage Temperature Range	T _{STG}	-55 to 125			°C				
Weight		2			lbs				
Size		5.5 x 6.55 x 2.3			inches	139.7 x 166.4 x 58.4 mm			

PARAMETER	SYMBOL	MIN	TYP	MAX	UNIT	NOTE
OUTPUT CURRENT						
Max Output Current	I _{MAX}	0.5, 1.0, 1.5, 2.0			A	
Compliance Voltage ³	V _{COMP}	16			V	with ±24 VDC power supplies
Short Term Stability, 1 hr		5	10	15	ppm	25°C
Long Term Stability, 24 hr		5	10	15	ppm	25°C
Temperature Coefficient		5	10	18	ppm / °C	
Delayed Start		1.25			sec	
Slow Start Ramp		100			msec	to full scale
Leakage Current		0.75	2	3	mA	
MODULATION						
Rise / Fall Time		250 / 200			nsec	to full scale
Slew Rate		30			V / μsec	
Depth of Modulation ⁴		90%				at 500 kHz
Bandwidth, 3 dB			2	3	MHz	

- Supply voltage can be changed; see **page 16**, and contact Sales, for information about Product Variations.
- Derating begins at 25°C. QCL2000 maximum operating temperature is 35°C.
- Compliance voltage can be increased to 20 V with Product variation PV072; requires +24 V and -28 V power supplies. Lower power supply input voltages are available by Product Variation. See **page 16**, and contact Sales, for information on Product Variations.
- Peak-to-Peak output amplitude decreases as frequency increases; see figure at right. Also see **page 16**.

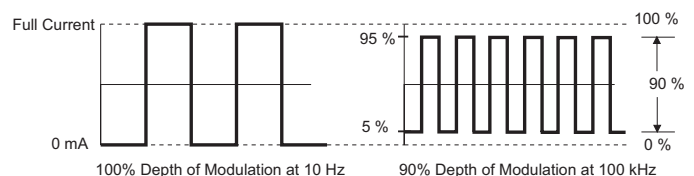

ELECTRICAL SPECIFICATIONS, CONTINUED

PARAMETER	SYMBOL	MIN	TYP	MAX	UNIT	NOTE
NOISE						
RMS Noise Current ^{5,6} QCL500 QCL1000 QCL1500 QCL2000			0.4 0.7 1.0 1.3		μA RMS	100 kHz bandwidth I _{OUT} = 500 mA
Average Noise Current Density ^{5,6} QCL500 QCL1000 QCL1500 QCL2000			1.0 2.0 3.0 4.0		nA / √Hz	R _{LOAD} = 10 Ω I _{OUT} = 500 mA
POWER SUPPLY						
Positive Supply Voltage ¹	V+	22	24	25	VDC	
Negative Supply Voltage ¹	V-	-22	-24	-25	VDC	
Quiescent Current, V+ Supply			250		mA	
Quiescent Current, V- Supply			100		mA	
Inrush Current Requirement ²			450		mA	
INPUTS						
Analog Input Range	ANALOG	-5 to +5			V	
Input Pin Impedance		1000			Ω	
Analog Input Damage Threshold		-10		10	V	
Remote Enable and Remote Power ON		must supply min of 5 mA. LO = < 3 V, HI = 5 to 12 V				HI = ON, LO = DISABLED / OFF
MONITORS AND OUTPUTS						
Current Setpoint Monitor Range	SET_MON	0		5	V	
Current Setpoint Monitor Accuracy ³			5		%	
Current Output Monitor Range	OUT_MON	0		5	V	
Current Monitor Bandwidth, 3 dB ⁴			1.8		MHz	
Current Monitor Stability			25		ppm	
Accuracy, Monitor to Actual Current			1.5		mA	
Limit Monitor Range	LIM_MON	0.4		5.75	V	
Accuracy, Limit Monitor to Actual Limit			0.1		%	
Status Outputs (Overtemp, Power, Enable)		Active HI 12 V output, source up to 25 mA				
+5V AUX POWER SUPPLY OUTPUT						
Output Voltage	+5V AUX		5		VDC	Selectable via internal jumper; see page 10
Output Current				500	mA	

- Supply voltage can be changed; see **page 16**, and contact Sales, for information about Product Variations.
- Negative power supply must source at least 450 mA. If current to QCL exceeds 450 mA, DC power supply capacity must be (QCL Current) + (Quiescent Current).
- Current Setpoint Monitor is a reference signal only, and may deviate from actual setpoint by up to 5%.
- Monitor bandwidth is less than the bandwidth of the current source. To monitor high frequency performance at full compliance, monitor output across a test load only. Do not place measurement equipment across an actual QCL—measurement equipment transients may damage or destroy the laser.
- See technical note [TN-LD02: “How is Current Noise Measured at Wavelength Electronics?”](#)
- We recommend that setpoint is below 85% of the current limit, because the noise level introduced into the QCL rises when operating close to the current limit.

SAFETY INFORMATION

SAFE OPERATING AREA – DO NOT EXCEED INTERNAL POWER DISSIPATION LIMITS

Before attempting to operate the QCL OEM driver, it is imperative that you first determine that the unit will operate within the *Safe Operating Area* (SOA). Operating the unit outside of the SOA may damage the driver and the QCL. Operating outside of the SOA will void the warranty.

To determine if the QCL driver is suitable for your application and if it will be operating in the safe range, consult the on-line instructions for calculating the Safe Operating Area:

<https://www.teamwavelength.com/support/design-tools/soa-ld-calculator/>
If you have questions about the Safe Operating Area calculator, call the factory for free and prompt technical assistance.



TO ENSURE SAFE OPERATION OF THE QCL CONTROLLER, IT IS IMPERATIVE THAT YOU DETERMINE IF THE UNIT IS GOING TO BE OPERATING WITHIN THE INTERNAL HEAT DISSIPATION SAFE OPERATING AREA (SOA).

USER SERVICEABLE COMPONENTS

The QCL driver is equipped with user-serviceable fuses. Refer to **page 15** if the fuses need to be replaced.

If you believe your controller needs maintenance or repair, please contact the factory immediately and do not attempt to maintain or repair the unit yourself.

THEORY OF OPERATION

The QCL Series low noise drivers are designed expressly to drive quantum cascade lasers, and utilize patented¹ circuitry to deliver ultra-low noise current and still maintain a wide modulation bandwidth.

The QCL drivers are controlled current sources; they deliver the current commanded by the setpoint. The current source continually monitors the actual output current, compares it to the setpoint, and adjusts the current if there is a difference between the two signals.

It may be useful to remember that you do not directly set the drive current setpoint. Instead, you adjust a voltage signal that represents the output current; the voltage is set either with the onboard trimpots or by an external input. The voltage and output current are related by a transfer function, described in **Table 3**. The current limit is set in a similar manner.

As current is driven through the load, there is a voltage drop across the load. As the current increases, the voltage drop may increase to the point that it reaches the Compliance Voltage limit of the current source. Once that occurs the current source is no longer able to increase the current driven to the load even if you increase the setpoint

The QCL OEM driver includes features that help protect your laser, and also make the driver more versatile in a wide array of applications. These features are explained in detail in the **Operating Instructions**.

- The user-adjustable soft-clamping current limit prevents overdriving the laser even if the analog input signal setpoint is above the maximum drive current for the laser. Details on current limit function are provided on **page 9**.
- Over- and under-voltage protection circuits protect the driver and QCL if the power supply voltages fall outside of the acceptable operating range.
- Over-temperature protection circuits safely shut down the output if the internal temperature of the QCL driver rises to an unsafe level.
- Output slow-start ramps the current to setpoint over 100 msec.
- A mechanical relay shorts the output connections when the output is disabled, and when the QCL driver is powered off.

The Analog Input can be used for adding to or subtracting from the internal setpoint on the QCL OEM. Inputting positive voltages will result in adding to the setpoint, while inputting negative voltages will result in subtracting from the setpoint.

1. Covered by U.S. Patents 6,696,887; 6,867,644 and 7,176,755.
Licensed from Battelle Memorial Institute.

OPERATING INSTRUCTIONS

These instructions are written for the most common operating mode of the QCL driver.

The controller is first configured for local control in order to set the drive current limit. Then the controller is reconfigured according to the actual application. We recommend using a test load until you are familiar with operation of the driver.

NECESSARY EQUIPMENT

- QCL Driver and QCL
- Digital multimeter (DMM), 4-½ digit resolution recommended
- Low-noise power supplies, 24 VDC; two required for bipolar power supply input
- Connector and cables for remote inputs and QCL output
- Connecting wires
- Test Load; recommended for driver setup

We recommend using the following equipment available from Wavelength Electronics:

- PWRPAK-24V – 24 V switching power supply; two required
- WCB312 – power supply wiring kit
- WCB311 – 14-pin I/O Cable (included)
- WCB313 – 3-pin QCL Power Cable (included)
- WCB314 – 4-pin QCL Load Cable (included)
- QCL TEST LOAD – resistive test load for setting up and configuring the driver

SAFE OPERATING AREA—DO NOT EXCEED INTERNAL POWER DISSIPATION LIMITS

The QCL driver is equipped with a heatsink that is sufficient for most operating environments. In high current applications, or when operating temperatures are elevated, forced airflow over the heatsink may be required.

Refer to the online SOA calculator to determine whether or not a fan will be necessary in your application.



IT IS IMPERATIVE THAT YOU VERIFY THE UNIT WILL OPERATE WITHIN THE INTERNAL HEAT DISSIPATION SAFE OPERATING AREA (SOA).

OPERATING THE DRIVER OUTSIDE THE SOA MAY DAMAGE OR DESTROY THE DRIVER AND/OR LASER.

PREVENT DAMAGE FROM ELECTROSTATIC DISCHARGE

Before proceeding, it is critical that you take precautions to prevent electrostatic discharge (ESD) damage to the driver and your laser. ESD damage can result from improper handling of sensitive electronics, and is easily preventable with simple precautions.

Enter the search phrase “ESD Precautions for Handling Electronics” in an internet search engine to find information on ESD-safe handling practices.

We recommend that you always observe ESD precautions when handling the QCL driver and your QCL.

THERMAL MOUNTING CONSIDERATIONS

The QCL driver is equipped with internal over-temperature protection circuitry. The FAULT LED on the front panel will illuminate, and the output will switch off if the protection circuitry detects an internal over-temperature condition.

To prevent over-temperature faults, the QCL driver should be mounted so that the heatsink receives adequate airflow. If the driver is installed in a case, the enclosure must be ventilated.

WIRE THE POWER SUPPLIES

Wire the QCL driver to the dual power supplies as shown in **Figure 4**. If you are using the PWRPAK-24V power supplies from Wavelength, we recommend you also use the wiring kits WCB312 and WCB313.

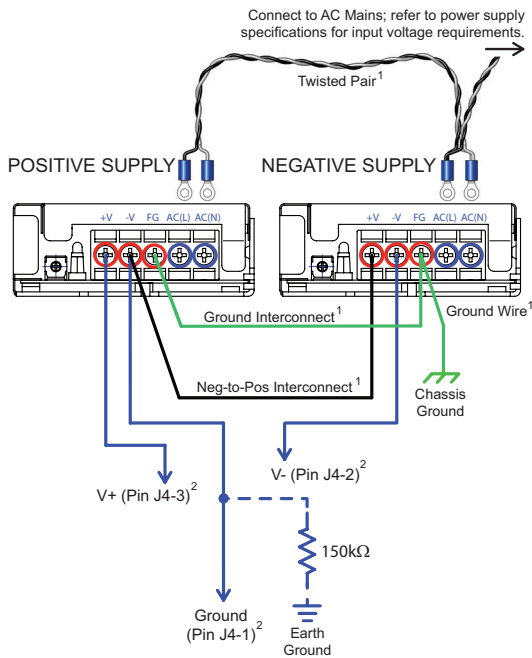

1. Cable included as part of the WCB312 Power Supply Wiring Kit
2. Included with the QCL Driver.

Figure 4. QCL Power Supply Wiring

Follow these instructions to wire the power supplies using the WCB312 and WCB313. The same method applies to connect other power supplies to the QCL driver.

- The AC Line (black) and Neutral (white) wires: 24 AWG black and white wires, 10" with ring lugs unattached but included in kit: connect the AC Line wire to the AC(L) terminals and the Neutral wire to the AC (N) terminals, as shown in **Figure 4**.
- AC Safety Ground #1: 24 AWG green wire, 10" with ring lugs on each end; connect to the Frame Ground terminals on the power supplies.
- AC Safety Ground #2: 24 AWG green wire; 10" with one ring lug; connect to the Frame Ground terminal on one power supply; connect the other end to Earth Ground (usually through the equipment rack, chassis, or optical bench).
- Common Ground: 24 AWG black wire; 10" with ring lugs on each end; connect between V- of Positive Supply and V+ of Negative Supply.
- Use the remaining ring lugs to connect the power supply cable (WCB313) to the V+, Power Ground, and V- terminals of the power supplies. See **page 20** for information on the WCB313 cable.

Figure 4 indicates a 150 kΩ resistor connecting the power supplies to ground; this resistor is necessary if the electronics ground is tied to earth ground at some point within your system, such as at a DAQ card, computer, or USB cable connection.

This resistor provides a lossy connection from system ground to earth ground, and will prevent the ground potential of isolated power supplies from drifting. **NOTE:** Some systems can have problematic ground loops. If this occurs, you may want to try and optically isolate the remote POWER and ENABLE lines. It is not a requirement for low noise operation, but it can be an option. (See **Table 4** for the remote Switch Settings.)

NOTE: For remote operation the front panel Power and Enable switches must be on.

If you are unsure whether to include this resistor in your system, contact Wavelength Electronics for technical assistance.

CONNECT THE TEST LOAD

It is very important to configure the QCL driver using a test load rather than the actual quantum cascade laser. Refer to **page 2** for test load specifications and wiring instructions. Connect the test load now.

SET THE CURRENT LIMIT

The QCL driver employs a soft-clamping current limit. The limit circuit begins to act at a current below the absolute limit setpoint, and will prevent the output current from ever exceeding the absolute limit setpoint.

We recommend that setpoint is below 85% of the current limit, because the noise level introduced into the QCL rises when operating close to the current limit.

First, zero the SET and LIMIT currents by turning the trimpots counter-clockwise; 21 turns for the SET trimpot and 12 turns for the LIMIT trimpot.

Next switch on the power supplies, then switch on the QCL driver by setting the POWER switch to ON (right); the blue POWER LED on the front panel will illuminate. Do not enable the output at this time.

The current limit is set using the LIMIT trimpot on the front panel:

- Refer to the datasheet for your QCL to find the maximum current, then calculate the Current Limit Monitor voltage, referencing **Table 3** for the transfer function:

$$V_{L_LIM_MON} = I_{LIMIT} / \text{Transfer Function}$$

- Connect the voltmeter to the Current Limit Monitor, pins J1:4 (positive) and J1:3 (negative/gnd).
- Adjust the LIMIT trimpot until the Current Limit Monitor voltage matches the calculated V_{LIMIT} value.

The procedure detailed here results in a practical current limit that is somewhat below the limit calculated using the transfer function. To set the current limit more accurately, refer to **page 15**.

ADJUST THE OUTPUT CURRENT USING THE SETPOINT MONITOR

The DC current setpoint is set by adjusting the SET trimpot on the front panel:

- Refer to the datasheet for your QCL to find the operating current, then calculate the Current Setpoint Monitor voltage using this equation and referencing **Table 3 on page 4** for the transfer function:

$$V_{SET_MON} = (I_{OUT} / \text{Transfer Function}) - 0.080 \quad (\text{V})$$

- Connect the voltmeter to the Current Setpoint Monitor, pins J1:6 (positive) and J1:3 (negative/gnd).
- Adjust the SET trimpot until the V_{SET_MON} value on the voltmeter matches the calculated V_{SET_MON} value.
- The SET_MON voltage is offset from the OUT_MON voltage by approximately 80 mV. To improve output setpoint accuracy, follow the procedure outlined in the next section.

ADJUST THE OUTPUT CURRENT USING THE CURRENT OUTPUT MONITOR

The DC current setpoint is set by adjusting the SET trimpot on the front panel:

- Refer to the datasheet for your QCL to find the operating current, then calculate the Current Output Monitor voltage using this equation and referencing **Table 3 on page 4** for the transfer function:

$$V_{OUT_MON} = I_{OUT} / \text{Transfer Function} \quad (\text{V})$$

- Connect the voltmeter to the Current Output Monitor, pins J1:5 (positive) and J1:3 (negative/gnd).
- Switch on the driver output using the ENABLE switch.
- Adjust the SET trimpot until the V_{OUT_MON} value on the voltmeter matches the calculated V_{OUT_MON} value.
- To further protect the QCL, the current limit can be decreased to just above the setpoint value by adjusting the LIMIT trimpot until the voltage just begins to decrease. Then increase the limit until the voltmeter reads the correct V_{OUT_MON} value again.

Once the driver is configured, disable the output then switch off the driver. Finally, switch off the power supplies.

CONFIGURE THE +5V AUX JUMPER

The QCL driver can be configured to provide a 5 VDC output on pin J5:1.

Changing the configuration requires opening the QCL driver case: In an ESD-safe environment, remove the eight Phillips screws located around the perimeter of the base of the unit; there are two screws on each side. Next remove the baseplate; the fit is intentionally tight and it will take some effort to remove the baseplate.

Refer to **Figure 5 on page 11** for the jumper location. Removing the jumper pin disables the +5V AUX output; placing the jumper over both pins of the header connects pin J5:1 to the +5V AUX supply. Pin J5:2 is Ground and is always connected to ground, regardless of the jumper position.

When the QCL driver is delivered, the +5 AUX output is Disabled.

Avoid driving noisy external circuits with the +5V AUX output; the external circuit may impact the QCL driver output noise level if adequate precautions are not taken to filter electronic noise.

CONFIGURE LOCAL VS. REMOTE CONTROL

The factory default configuration is with onboard Power and Enable switches active, and the remote signals are inactive.

NOTE: For remote operation the front panel Power and Enable switches must be on.

The QCL driver case must be opened in order to access the switches. The DIP switches are located on the bottom of the circuit board, as illustrated in **Figure 5**.

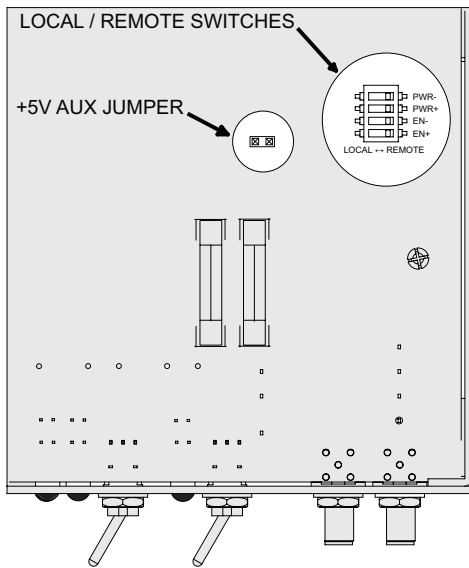

Figure 5. Bottom View of QCL Driver Showing the Internal Remote / Local Switches and +5V AUX Jumper

Table 4 details the switch settings for Local vs. Remote control. The Remote input signals can be optically isolated, or they can be tied to the instrument ground. Choosing whether or not to isolate the remote Power and Enable functions depends on the control system configuration:

- Isolate the inputs when using a computer or DAQ card to generate the control signals. Computers and DAQ cards are typically very noisy, and optically isolating these inputs will prevent that noise from conducting to the QCL driver and laser.
- Isolating the remote inputs requires two I/O lines per function, one for the signal and one for the return. If there is not a sufficient number of I/O lines on the DAQ card, the functions can't be isolated.
- If the ground potential resistor is installed, see the wiring diagram in **Figure 4**.

Table 4. Local vs. Remote Switch Settings

SWITCH	NO.	ON (LEFT)	OFF (RIGHT)
ON OFF 	4	Remote Signal Tied to Driver Ground	Remote Signal Optically Isolated
	3	Local Power Switch	Remote Power Signal
	2	Remote Signal Tied to Driver Ground	Remote Signal Optically Isolated
	1	Local Output Enable Switch	Remote Output Enable Signal
Note:		If Switch 1 is ON, Switch 2 must also be ON If Switch 3 is ON, Switch 4 must also be ON	

Once the switches are configured reassemble the chassis and tighten the screws.

COMPLETE ADDITIONAL WIRING

If the remote power and enable functions of the QCL driver are being used, connect them to the control electronics. Also connect external electronics for status monitoring. Refer to **Table 1** for specifications on each connection.

ANALOG SETPOINT INPUT

The external analog setpoint signal sums with the onboard SET trimpot. To calculate the analog input signal voltage, reference **Table 3** for the transfer function, and use the following equation:

$$V_{ANALOG} = I_{SETPOINT} / \text{Transfer Function}$$

The V_{ANALOG} signal can be -5 V to +5 V.

If the analog setpoint input causes the driver to reach the current limit, the output signal will be clamped at the limit level but will not switch off. Refer to **page 15** for information on current limit circuit response to modulated analog setpoint input signals.

The bandwidth of the Current Monitor is lower than the bandwidth of the output. To monitor the actual output waveform at high frequencies, connect an oscilloscope across the output pin J5:4 (positive) and J5:3 (negative/gnd) while using the resistor test load.



CONNECT THE OSCILLOSCOPE ACROSS THE TEST LOAD ONLY—NEVER CONNECT THE OSCILLOSCOPE ACROSS A QUANTUM CASCADE LASER.

CONNECT THE QUANTUM CASCADE LASER

Once you are comfortable with operating the QCL driver, disable the output, switch off all power to the driver, disconnect the test load, and connect the laser. Refer to **Figure 6** for proper wiring polarity.

Note that the Positive Terminal of the QC Laser is connected to ground, and the Negative Terminal is connected to the Driver. The QCL driver acts as a *current sink*.

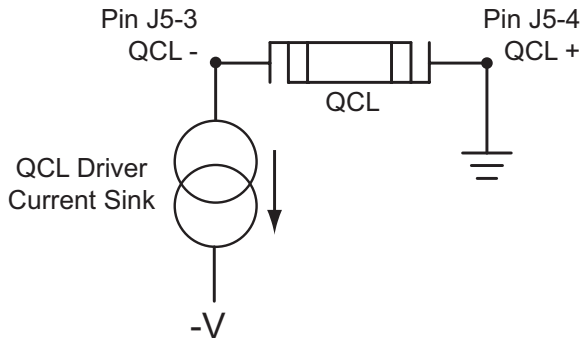

Figure 6. QCL Wiring and Polarity

RECOVER FROM AN INTERNAL OVER-TEMPERATURE FAULT

The QCL driver is equipped with a protection circuit to switch off the output if the internal temperature exceeds a safe operating value. If an over-temperature fault is detected the FAULT LED will illuminate red, and the signal on J1:7 will go HI. Switch off the output using the onboard switch or the remote output enable signal. The QCL will not allow the output to be enabled until the internal temperature is within the safe operating range.

ENABLE THE QCL DRIVER OUTPUT

Enable the output current by setting the ENABLE switch to ON (right). The blue ENABLE LED on the front panel will illuminate. The output is disabled by setting the switch to the OFF position (left).

RECOVER FROM A POWER SUPPLY PROTECTION CIRCUIT FAULT

If the voltage from the dual power supplies is over or under voltage limits, the protection circuit will disable the output and latch the driver in a FAULT state. If a fault is indicated, switch off the QCL driver and power supplies.

After correcting the cause of the power supply error, the driver must be reset. Toggle the Power OFF then ON using either the remote signal or front panel switch. After switching on the power, wait one second to re-enable current.

If supply voltage to the QCL driver is reversed, protection circuits activate and the current from the power supplies is shunted through a protection diode. The internal fuses may blow, and the QCL driver will not operate under this condition. Switch off all power, correct the error, and re-enable the driver.

TROUBLESHOOTING

PROBLEM	POTENTIAL CAUSES	SOLUTIONS
Driver will not switch on	Improperly configured power supplies	Carefully check the wiring diagram in Figure 2 on page 2 . Make sure the power supply polarity is not reversed. The FAULT LED will illuminate red if the driver is switched on with reversed power supply polarity.
	Internal fuses are blown	In an ESD-safe environment, open the QCL driver chassis and verify the fuses are not blown. Replace the fuses if necessary. Refer to page 15 .
Output will not enable	Improperly configured Remote switches on the QCL unit	Make sure that the Remote switches in the QCL driver are set to the correct position for your application. Refer to Configure Local vs. Remote Control on page 11 .
	Remote Enable signal is not correct	If the driver is configured to reference the Remote inputs, make sure the signals are correct. Disconnect the remote input lines and check them independently of the driver. Refer to Table 1 on page 3 .
	The QCL driver detected a power supply fault	If the red FAULT LED is illuminated, the protection circuitry has detected a fault condition on the power supply inputs. Refer to Recover from a Power Supply Protection Circuit Fault on page 12 .
	The QCL driver detected an over-temperature condition	If the red FAULT LED is illuminated and the signal on J1:7 is HI, the protection circuitry has detected an over-temperature fault condition. Refer to page 12 .
Noise current is higher than expected	There may be ground loops in the system; some system components may be higher noise than expected; cabling and shielding may be inadequate	Refer to Wavelength Electronics Application Note <i>AN-LD08: "Manage Grounding to Minimize Noise with the QCL Drivers"</i> : https://www.teamwavelength.com/download/applicationtechnotes/an-ld08.pdf Also reference <i>AN-LD09: "Troubleshooting Low Noise Systems"</i> : https://www.teamwavelength.com/download/applicationtechnotes/an-ld09.pdf
	Switching power supplies may be noisy	Use the best quality switching power supplies you can find. We test our QCL drivers using our stock PWRPAK-24V power supplies.
The output switched off unexpectedly	The QCL driver detected a power supply fault	If the red FAULT LED is illuminated the protection circuitry has detected a fault condition on the power supply inputs. Refer to Recover from a Power Supply Protection Circuit Fault on page 12 .
	The QCL driver detected an over-temperature condition	If the red FAULT LED is illuminated and the signal on J1:7 is HI, the protection circuitry has detected an over-temperature fault condition.
Laser output power lower than expected	Current limit set too low	Using a test load (see Figure 3 on page 2) follow the procedure to set the current limit (page 9). Verify that the current limit is suitable for your laser by connecting the voltmeter across R_{LOAD} ; calculate the drive current using Ohm's Law ($V = I * R$).
20 kHz noise is in the output current	QCL driver is operating in current limit	If safe for the quantum cascade laser, increase the output current limit setting. When actively operating in current limit, the safety circuits add noise to the output.
If I run my QCL at about 5% of maximum output current, the transfer function becomes non-linear and I see distortion in my output current waveform.	QCL driver resolution is too low	Select a QCL driver with a much lower maximum output current. For example, to run 50 mA, request a QCL125 (125 mA maximum output).

TECHNICAL SUPPORT INFORMATION

This section includes useful technical information on these topics:

- Revision A – C Wiring Diagram
- Revision A – C Transfer Functions
- Replace the Internal Fuses
- Soft-Clamp Current Limit
- Square Wave Response
- Drive LEDs With the Status Outputs
- Product Variations
- Optimizing the System for Low Noise
- Safe Operating Area Calculation

QCL OEM REV A – C TRANSFER FUNCTIONS

The transfer functions for production revisions A – C are shown in **Table 5** and **Table 6**.

Table 5. Current Limit Monitor and Setpoint Transfer Functions—Revisions A – B

MODEL	CURRENT OUTPUT MONITOR	CURRENT LIMIT MONITOR	ANALOG INPUT
QCL500	0.2 A/V	0.09 A/V	0.1 A/V
QCL1000	0.4 A/V	0.19 A/V	0.2 A/V
QCL1500	0.6 A/V	0.28 A/V	0.3 A/V
QCL2000	0.8 A/V	0.39 A/V	0.4 A/V

Table 6. Current Limit Monitor and Setpoint Transfer Functions—Revision C

MODEL	CURRENT OUTPUT MONITOR	CURRENT LIMIT MONITOR	ANALOG INPUT
QCL500	0.1 A/V	0.09 A/V	0.1 A/V
QCL1000	0.2 A/V	0.19 A/V	0.2 A/V
QCL1500	0.3 A/V	0.28 A/V	0.3 A/V
QCL2000	0.4 A/V	0.39 A/V	0.4 A/V

QCL OEM REVISION A – C WIRING DIAGRAM

Refer to **Figure 7** for information on wiring earlier revisions of the QCL driver.

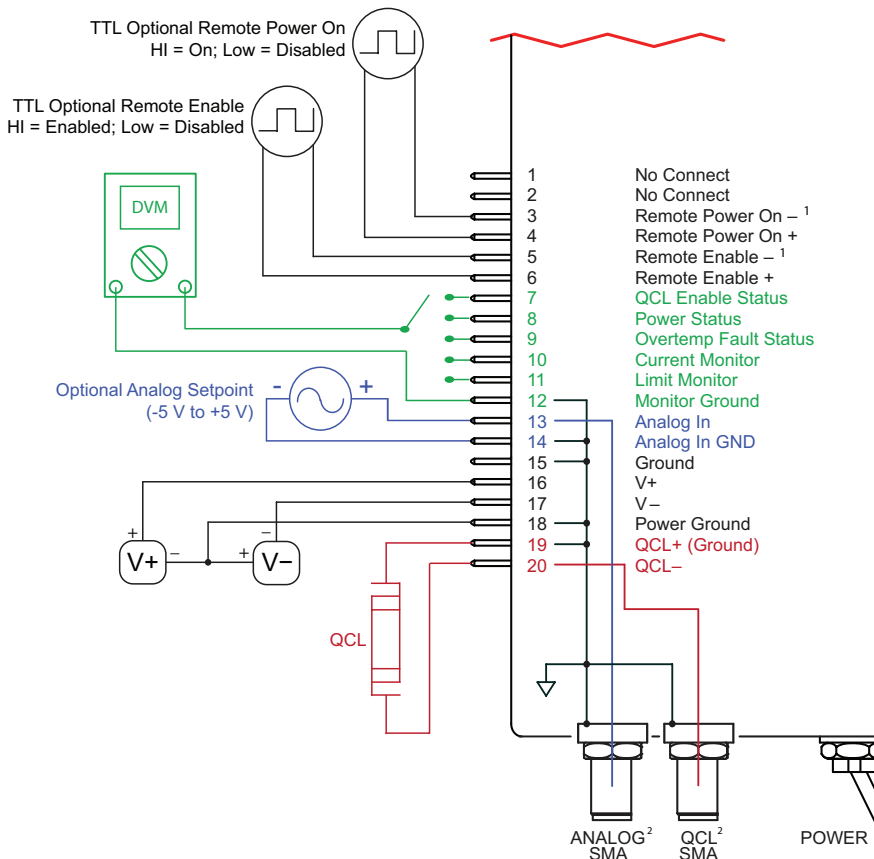

1. The Remote Power On - and Remote Enable - inputs can be optically isolated from ground.
 2. The SMA connectors are electrically isolated from the QCL chassis.

Figure 7. Revision A – C Wiring Diagram

REPLACE THE INTERNAL FUSES

The QCL driver is equipped with two internal fuses. If the QCL driver will not power on and you have verified that the power supplies are wired and working properly, check and replace these two fuses. See **Figure 8** for the fuse location. The fuses are 5 A, 5 x 20 mm, SLO-BLO fuses.

In an ESD-safe environment, remove the eight Phillips screws around the base of the unit. Then remove the baseplate—the fit is intentionally tight and will require some effort.

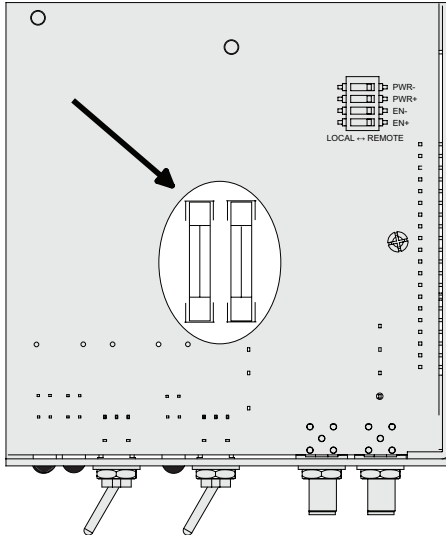

Figure 8. Location of Internal Fuses

Replace the fuses, then reinstall the chassis cover and tighten the eight screws.

SOFT-CLAMP CURRENT LIMIT

The QCL driver employs a soft-clamping current limit that begins to act at a current lower than the calculated absolute current limit. We recommend that setpoint is below 85% of the current limit, because the noise level introduced into the QCL rises when operating close to the current limit.

Normally, the LIM_MON voltage is calculated using the transfer function shown in **Table 3**. Using the transfer function to set the LIM_MON voltage sets the *absolute* current limit, which is the current that will not be exceeded under any circumstance.

Because of the soft-clamp circuit, the actual current where the limit circuit begins to act is *offset* from the calculated absolute current limit. The Limit Offset Current is calculated as follows, where X_{LIM_MON} is the current limit transfer function for the QCL driver model you are using (see **Table 3**):

$$\text{Limit Offset Current} = X_{LIM_MON} * (V_{LIM_MON} - 0.4) \text{ (A)}$$

If the output current is between the Limit Offset Current and the Absolute Current Limit, the output response to the analog input setpoint is nonlinear. The result is that the drive current will asymptotically approach the absolute current limit, and will never exceed it even if the analog input setpoint voltage far exceeds the current limit voltage.

Figure 9 illustrates the behavior of the soft-clamp current limit. In this case the analog input voltage setpoint signal is a triangle wave, with the amplitude set so that the driver will attempt to overdrive the current limit.

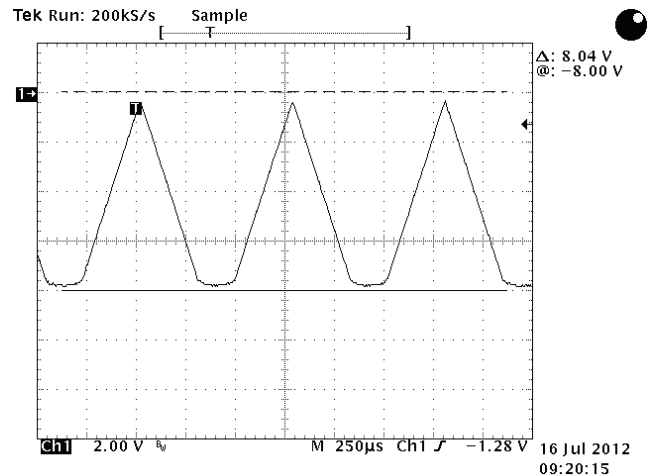

Figure 9. Soft Clamping Current Limit Behavior

SQUARE WAVE RESPONSE

Figure 10 and Figure 11 illustrate the modulation response of the QCL1000 driven at 1.15 A into a 10 Ω test load.

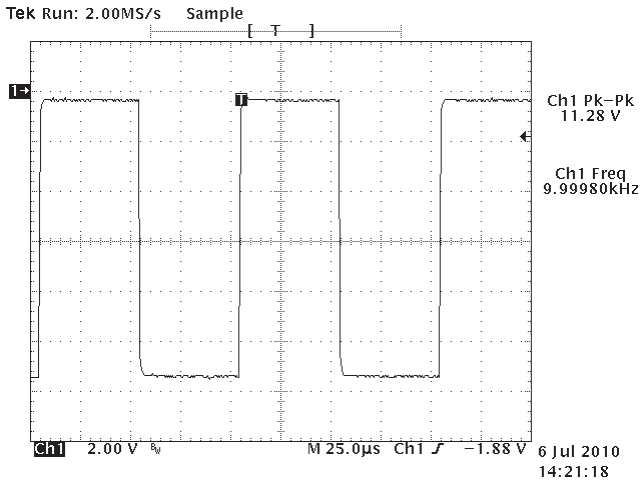

Figure 10. 10 kHz Output Plot
QCL1000 at 1.15 A with 10 Ω Test Load

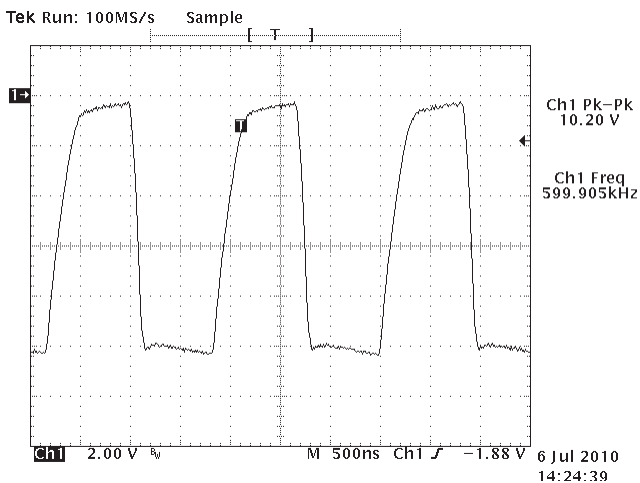

Figure 11. 600 kHz Output Plot
QCL1000 at 1.15 A with 10 Ω Test Load

DRIVE LEDs WITH THE STATUS OUTPUTS

In the ON state the Status pins output a 12 V signal, sourcing up to 25 mA, and can be used to drive indicator LEDs. Assuming $V_F = 2\text{ V}$ and a drive current requirement of 10 mA, LEDs can be connected per Figure 12. Adjust the resistor value to match the current and voltage requirements of the LED.

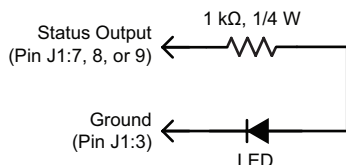

Figure 12. Wiring Status LEDs

PRODUCT VARIATIONS

We design and manufacture our products in-house, and that gives us the unique ability to modify our drivers and controllers to suit exactly your application. Our Product Variation service allows us to quickly and cost-effectively address your design requests, from prototype quantities to long-term high-volume manufacturing.

Examples of Product Variations include:

- Increase the compliance voltage limit with PV055-C: compliance voltage can be increased to 20 V, and requires power supply inputs of +24 V and -30 V.
- Replace current limit trimpots with fixed-value resistors to maximize stability in an OEM laser controller.
- Optimize heatsink size and configuration to fit within the space constraints of your electronics chassis.
- Increase the maximum output current.
- Lower the controller input voltage with PV066-A: power supply input voltage of ±15 V results in an output compliance voltage of 7 V. Other input voltage ranges can be accommodated, as well.

Contact Sales for information on how a Product Variation can be applied in your situation.

REVERSE POLARITY UNIT AVAILABLE

Often, with epi-down configurations of a QCL, the exit lead is attached to the case and it is desirable to ground it. Now, the reverse polarity driver, a current source, is also available in the OEM package.

The difference is shown in Figure 13 below.

QCLSTANDARD

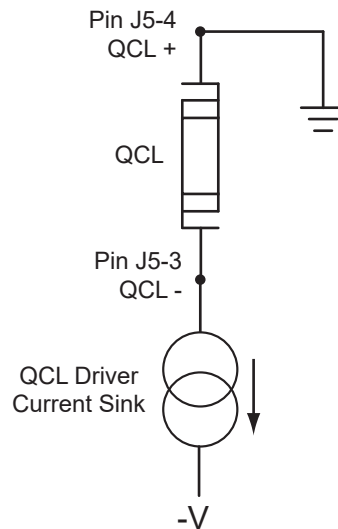

QCL(+)

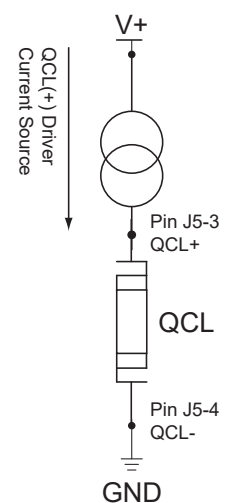

Figure 13. Polarity Comparison

More detailed information is available in the [QCL OEM\(+\) Series datasheet](#).

OPTIMIZING THE SYSTEM FOR LOW NOISE

The QCL driver is designed to deliver extremely low noise drive current to the quantum cascade laser, but other factors must also be considered for optimum system performance.

Wavelength Electronics provides a number of resources on our website that will help you understand noise sources and how to eliminate them. Visit this link:

<https://www.teamwavelength.com/support/reference/>

One of the most important components affecting noise performance is the power supply used to power the QCL driver. Wavelength has extensively tested the TDK/Lambda switching power supply, and recommends this power supply for most QCL applications (available as our part number PWRPAK-24V, two required per driver).

Proper grounding technique is also critical. Always ensure there are no ground loops within the system. Grounding the chassis of the QCL driver will help reduce 50/60 Hz noise.

Figure 14 through **Figure 16** illustrate the benefits of using high-quality switching power supplies and grounding the chassis.

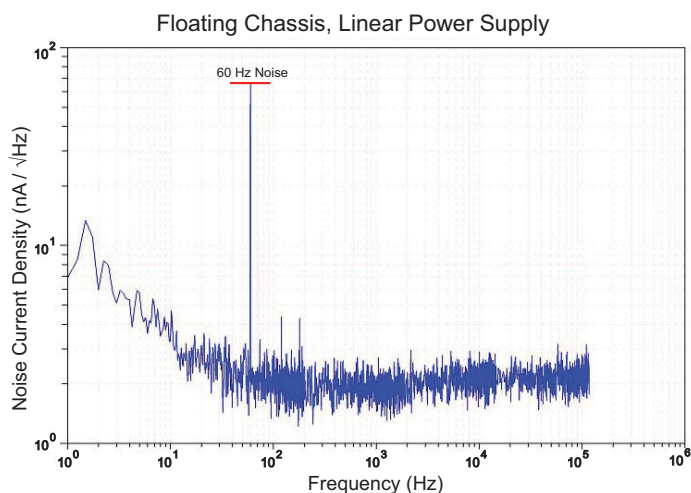

Figure 14. Noise Plot with Floating Chassis and Linear Power Supplies

Leaving the chassis ungrounded and using a low-quality linear power supply introduces a very strong 60 Hz noise signature on the output. In most applications this strong 60 Hz signature will negatively impact QCL performance, so it is critical to ground the chassis to achieve the best system performance.

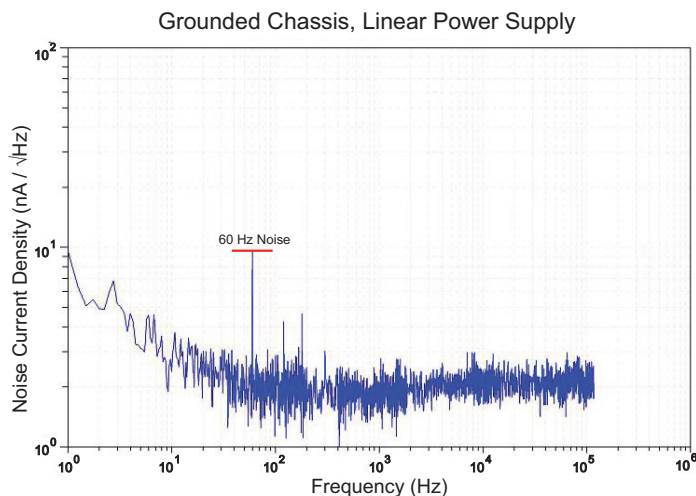

Figure 15. Noise Plot with Grounded Chassis and Linear Power Supplies

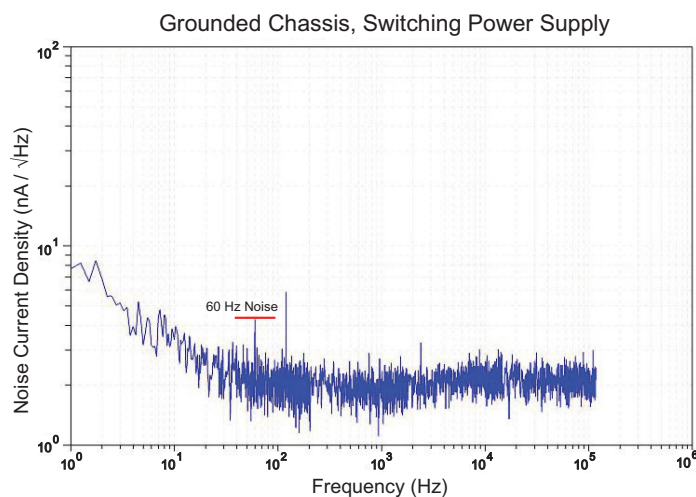

Figure 16. Noise Plot with Grounded Chassis and High Quality Switching Power Supplies

Additional recommendations to minimize noise:

- Use high quality power supplies, and test the power supplies independent of the laser driver system in order to ensure they are performing at a level that will not introduce unacceptable noise.
- Use filters on the power supplies; off-the-shelf EMI filters such as the TDK/Lambda MAW Series will provide a noticeable benefit.
- Use low-noise analog input signal generators. Even “low noise” function generators have a significant noise signature that may negatively impact system performance.
- If a fan is required to help keep the driver cool, do not wire the fan to the same power supplies used to power the driver. Fans are notoriously noisy.
- Use the shortest possible power, control, and laser leads. Use twisted pairs, shielded cables, and shielded connectors.

SAFE OPERATING AREA CALCULATION

The Safe Operating Area of the QCL is determined by the amount of power that can be dissipated within the output stage of driver. If that power limit is exceeded permanent damage can result.



DO NOT OPERATE THE QCL DRIVER OUTSIDE OF THE SAFE OPERATING AREA CURVE.

OPERATING THE QCL DRIVER OUTSIDE OF THE SOA VOIDS THE WARRANTY.

Refer to the Wavelength Electronics website for the most up-to-date SOA calculator for our products. The online tool is fast and easy to use, and also takes into consideration operating temperature.

<https://www.teamwavelength.com/support/design-tools/soa-ld-calculator/>
SOA charts are included in this datasheet for quick reference. We recommend you use the online tools instead.

Follow these steps to determine if the driver will be operating within the SOA.

- Refer to the QCL laser datasheet to find the maximum voltage (V_{QCL}) and current (I_{MAX}) specifications.
- Calculate the voltage drop across the controller:

$$V_{DROP} = |V-| - V_{QCL} \text{ (V- is the negative power supply voltage)}$$

- Mark V_{DROP} on the X-axis, and extend a line upward.
- Mark I_{MAX} on the Y-axis, and extend a line to the right until it intersects the V_{DROP} line.
- On the X-axis, mark the value of the negative supply voltage.
- Extend a diagonal line from V- to the intersection of the other two lines; this is the Load Line.
- If the Load Line crosses the Safe Operating Area line at any point, the configuration is not safe.

If the SOA calculator indicates the QCL will be outside of the Safe Operating Area, the system must be changed so that less power is dissipated within the driver. See Wavelength Electronics Application Note [AN-LDTC01: The Principle of the Safe Operating Area](#) for information on shifting the Load Line.

After changing any of the parameters, recalculate the SOA to make sure the controller will operate safely. If you have questions, or run into difficulties calculating the SOA, contact Wavelength Electronics for assistance.

QCL500 SAFE OPERATING AREA

The QCL500 will safely operate over the full drive current range at 25°C, and no additional airflow is required over the heatsink. For operating temperatures above 25°C, refer to the online SOA calculator.

Depending on the results of the SOA calculation, the QCL1000, QCL1500, and QCL2000 may require airflow over the heatsink in order to safely operate.

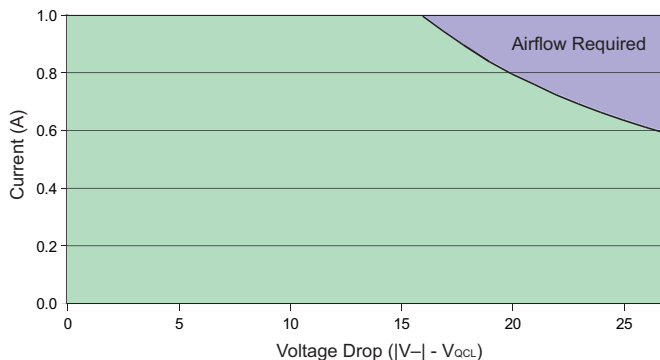

Figure 17. QCL1000 SOA Chart, at 25°C

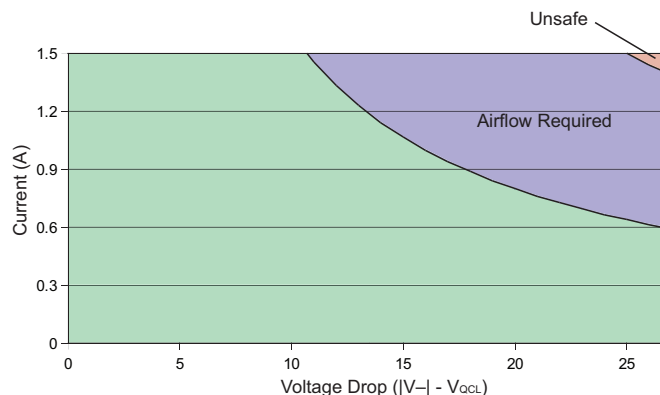

Figure 18. QCL1500 SOA Chart, at 25°C

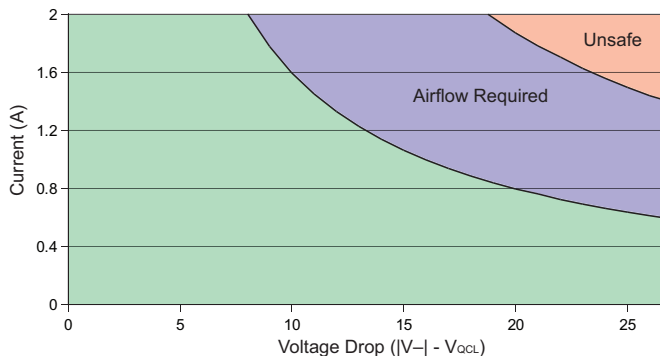
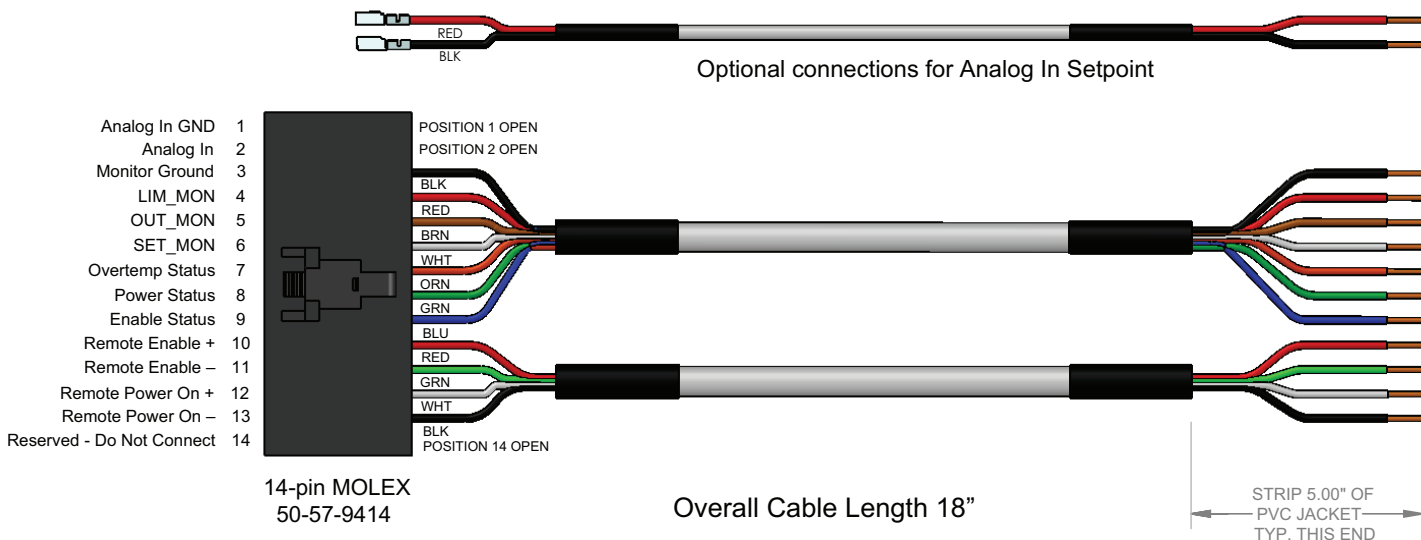

Figure 19. QCL2000 SOA Chart, at 25°C

CABLE SPECIFICATIONS

WCB311 – 14-PIN I/O CABLE; ONE INCLUDED WITH QCL OEM DRIVER



WCB312 – POWER SUPPLY WIRING KIT

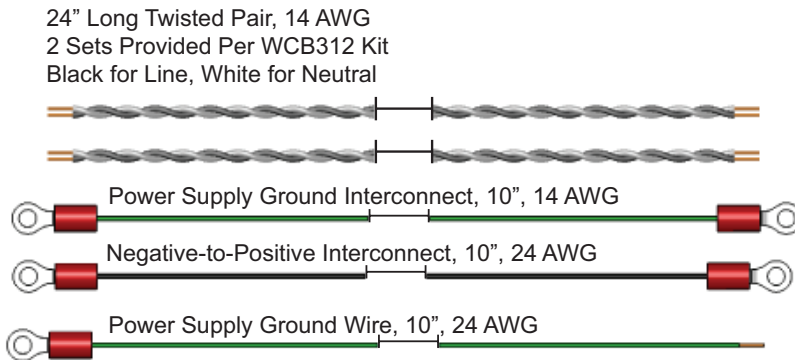

The WCB312 Power Supply Wiring Kit includes the wires illustrated above, and also includes crimp-type ring lugs:

- (6) blue lugs for 14 AWG wire
- (3) red lugs for 24 AWG wire.

If using the PWRPAK-24 power supplies available from Wavelength, connect the cables as shown in **Figure 4 on page 9**. If different power supplies are used, the connection and wiring principles are the same.

- The AC Line (black) and Neutral (white) wires: 24 AWG black and white wires, 10" with ring lugs unattached but included in kit: connect the AC Line wire to the AC(L) terminals and the Neutral wire to the AC (N) terminals, as shown in **Figure 4 on page 9**
- AC Safety Ground #1: 24 AWG green wire, 10" with ring lugs on each end; connect to the Frame Ground terminals on the power supplies.
- AC Safety Ground #2: 24 AWG green wire; 10" with one ring lug; connect to the Frame Ground terminal on one power supply; connect the other end to Earth Ground (usually through the equipment rack, chassis, or optical bench).
- Common Ground: 24 AWG black wire; 10" with ring lugs on each end; connect between V- of the Positive Supply and V+ of the Negative Supply.
- Use the remaining ring lugs to connect the wires from WCB313 to the V+, V-, and Power Ground terminals of the power supplies. The wires on the WCB313 are pins 3, 2, and 1, respectively.

WCB313 – 3-PIN QCL POWER CABLE; ONE INCLUDED WITH QCL OEM DRIVER

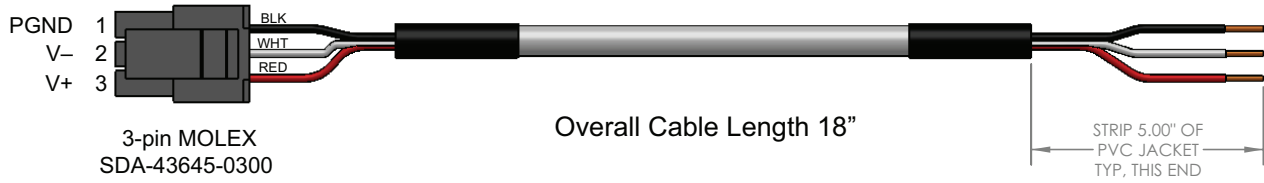

WCB314 – 4-PIN QCL LOAD CABLE; ONE INCLUDED WITH QCL OEM DRIVER

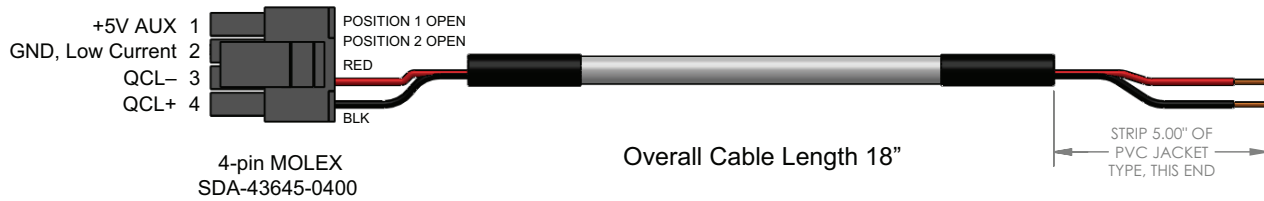
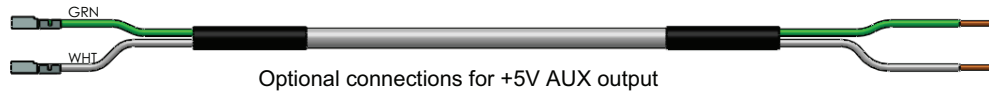

MECHANICAL SPECIFICATIONS - PWRPAK-24V POWER SUPPLY

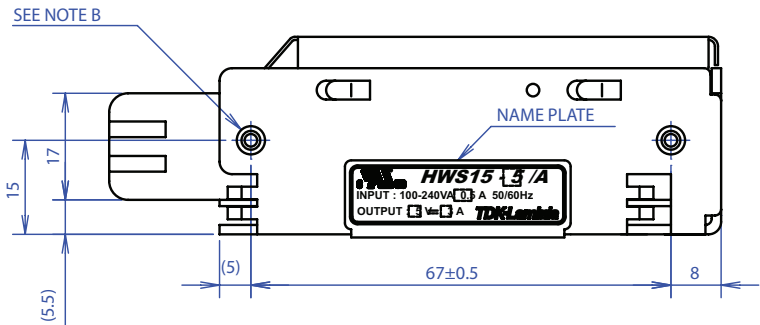
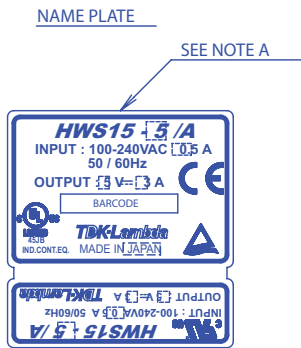
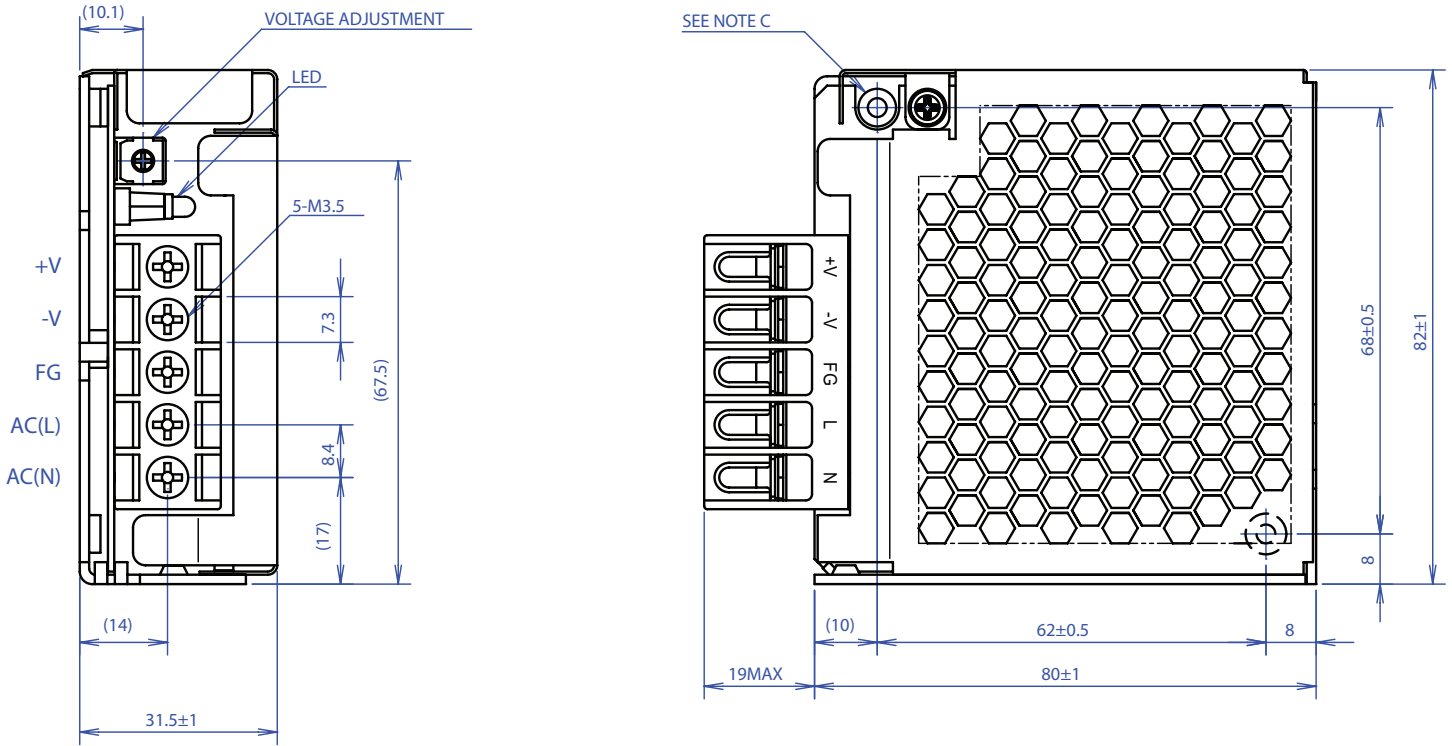

NOTES

- A : MODEL NAME, INPUT VOLTAGE RANGE, NOMINAL OUTPUT VOLTAGE, MAXIMUM OUTPUT CURRENT AND COUNTRY OF MANUFACTURE ARE SHOWN HERE IN ACCORDANCE WITH THE SPECIFICATIONS.
- B : M3 EMBOSSED, TAPPED AND COUNTERSUNK HOLES (2) FOR CUSTOMER CHASSIS MOUNTING. SCREWS MUST NOT PROTRUDE INTO POWER SUPPLY BY MORE THAN 6m/m.
- C : M3 TAPPED HOLES (2) FOR CUSTOMER CHASSIS MOUNTING. SCREWS MUST NOT PROTRUDE INTO POWER SUPPLY BY MORE THAN 6m/m.

(unit : mm)

MODEL	HWS15/A
DENSEI-LAMBDA	

A224-02-01/A-A

Figure 20. Power Supply Mechanical Specifications

Diagram courtesy TDK-Lambda.
Specifications subject to change.

MECHANICAL SPECIFICATIONS

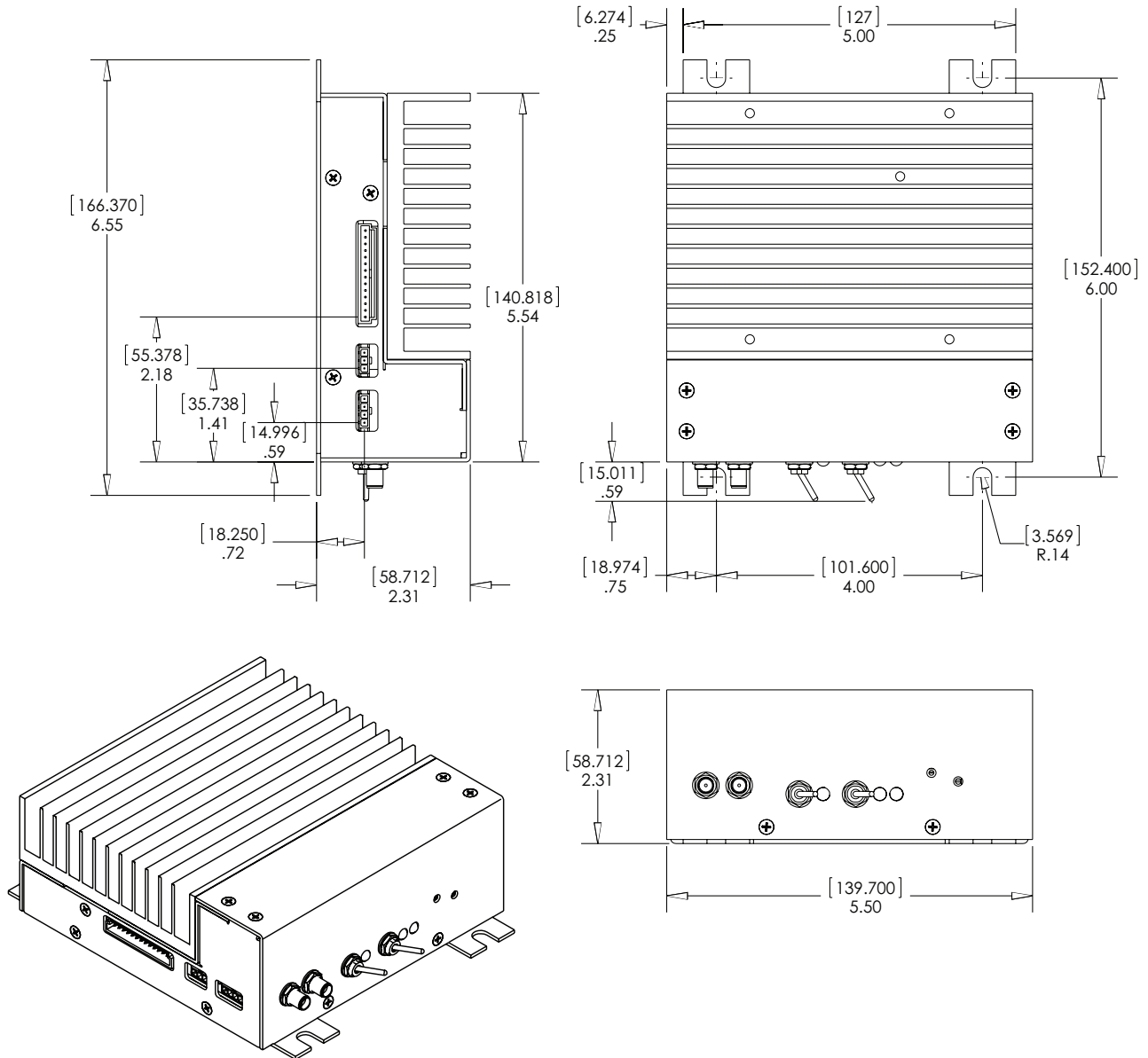

Figure 21. QCL OEM Driver Mechanical Dimensions

The QCL OEM Driver must be firmly secured by the baseplate mounting tabs, and not supported by the cable connectors. Use either 1/4-20 screws for mounting (4 places), or #8 screws with a shoulder washer (4 places).

All Dims in [mm] inches; Tolerance ±5%

CERTIFICATION AND WARRANTY

CERTIFICATION

Wavelength Electronics, Inc. (Wavelength) certifies that this product met its published specifications at the time of shipment. Wavelength further certifies that its calibration measurements are traceable to the United States National Institute of Standards and Technology, to the extent allowed by that organization's calibration facilities, and to the calibration facilities of other International Standards Organization members.

WARRANTY

This Wavelength product is warranted against defects in materials and workmanship for a period of one (1) year from date of shipment. During the warranty period, Wavelength will, at its option, either repair or replace products which prove to be defective.

WARRANTY SERVICE

For warranty service or repair, this product must be returned to the factory. An RMA is required for products returned to Wavelength for warranty service. The Buyer shall prepay shipping charges to Wavelength and Wavelength shall pay shipping charges to return the product to the Buyer upon determination of defective materials or workmanship. However, the Buyer shall pay all shipping charges, duties, and taxes for products returned to Wavelength from another country.

LIMITATIONS OF WARRANTY

The warranty shall not apply to defects resulting from improper use or misuse of the product or operation outside published specifications. No other warranty is expressed or implied. Wavelength specifically disclaims the implied warranties of merchantability and fitness for a particular purpose.

EXCLUSIVE REMEDIES

The remedies provided herein are the Buyer's sole and exclusive remedies. Wavelength shall not be liable for any direct, indirect, special, incidental, or consequential damages, whether based on contract, tort, or any other legal theory.

REVERSE ENGINEERING PROHIBITED

Buyer, End-User, or Third-Party Reseller are expressly prohibited from reverse engineering, decompiling, or disassembling this product.

NOTICE

The information contained in this document is subject to change without notice. Wavelength will not be liable for errors contained herein or for incidental or consequential damages in connection with the furnishing, performance, or use of this material. No part of this document may be translated to another language without the prior written consent of Wavelength.

SAFETY

There are two fuses within the chassis that are user-serviceable. There are no other user-serviceable parts inside this product. Return the product to Wavelength Electronics for service and repair to ensure that safety features are maintained.

LIFE SUPPORT POLICY

This important safety information applies to all Wavelength electrical and electronic products and accessories:

As a general policy, Wavelength Electronics, Inc. does not recommend the use of any of its products in life support applications where the failure or malfunction of the Wavelength product can be reasonably expected to cause failure of the life support device or to significantly affect its safety or effectiveness. Wavelength will not knowingly sell its products for use in such applications unless it receives written assurances satisfactory to Wavelength that the risks of injury or damage have been minimized, the customer assumes all such risks, and there is no product liability for Wavelength. Examples of devices considered to be life support devices are neonatal oxygen analyzers, nerve stimulators (for any use), auto-transfusion devices, blood pumps, defibrillators, arrhythmia detectors and alarms, pacemakers, hemodialysis systems, peritoneal dialysis systems, ventilators of all types, and infusion pumps as well as other devices designated as "critical" by the FDA. The above are representative examples only and are not intended to be conclusive or exclusive of any other life support device.

PATENTED TECHNOLOGY

Covered by U.S. Patents 6,696,887; 6,867,644; and 7,176,755. Licensed from Battelle Memorial Institute.

REVISION HISTORY

DOCUMENT NUMBER: QCL1500-00400

REV.	DATE	CHANGE
P	August 2015	Clarified instructions for remote operation
Q	January 2016	Added reference to QCL OEM(+)
R	May 2016	Included PV information in max power supply section
S	May 2017	Updated Analog Input settings.
T	March 2019	Updated Pin 10 & 12 description

