

Avalanche Photodiodes

Ultra High Gain Silicon Photodetectors

Silicon Avalanche Photodiodes make use of internal multiplication to achieve gain due to impact ionization. The result is the optimized series of high Responsivity devices, exhibiting excellent sensitivity. OSI Optoelectronics offers several sizes of detectors that are available with flat windows or ball lenses for optical fiber applications.

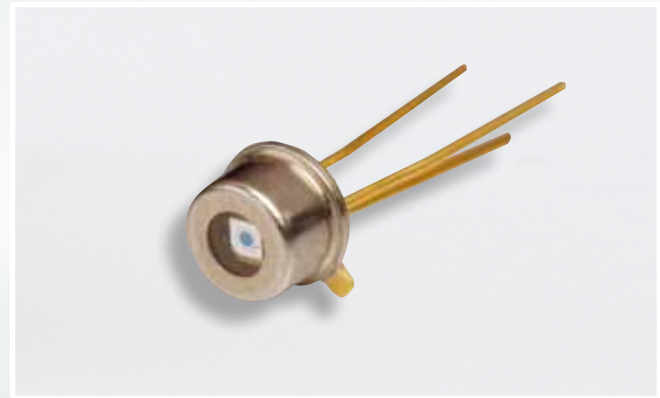

APPLICATIONS

- High Speed Optical Communications
- Laser Range Finder
- Bar Code Readers
- Optical Remote Control
- Medical Equipment
- High Speed Photometry

FEATURES

- High Responsivity
- High Bandwidth / Fast Response
- Low Noise
- Low Bias Voltage
- Hermetically Sealed TO-Packages

Electro-Optical Characteristics ($T_A = 23^\circ\text{C}$, typical values at gain listed, unless otherwise specified)

Product Model	Active Area		Responsivity @Gain M $\lambda = 800\text{ nm}$ (A/W)	Dark Current Gain M (nA)		Ct Gain M (pF)	Q.E. M = 1 $\lambda = 800\text{ nm}$ (%)	Breakdown Voltage 100 μA (V)		Temperature Coefficient of Breakdown Voltage (V/ $^\circ\text{C}$)	Bandwidth -3dB Gain M $\lambda = 800\text{ nm}$ (MHz)	Excess Noise Figure Gain M $\lambda = 800\text{ nm}$	Gain M $\lambda = 800\text{ nm}$	Storage Temperature ($^\circ\text{C}$)	Operating Temperature ($^\circ\text{C}$)	Package Style * 2
	Diameter*1 (mm)	Area (mm 2)		Typ	Max			Typ	Max							
APD02-8-150-T52	0.2	0.03	50	0.05	1	1.5	75	150	250	0.45	1000	0.3	100	-55 ~ +125	-40 ~ +100	65 / TO-52 or 66 / TO-52L
APD05-8-150-T52	0.5	0.19		0.1	1	3	75	150	250	0.45	900	0.3	100			65 / TO-52 or 66 / TO-52L
APD10-8-150-T52	1.0	0.78		0.2	2	6	75	150	250	0.45	600	0.3	100			65 / TO-52 or 66 / TO-52L
APD15-8-150-T05	1.5	1.77		0.5	5	10	75	150	250	0.45	350	0.3	100			67 / TO-5
APD30-8-150-T05	3.0	7.0	30	1	10	40	75	150	250	0.45	65	0.3	60			67 / TO-5
APD50-8-150-T08	5.0	19.6	20	3	30	105	75	150	250	0.45	25	0.3	40			3 / TO-8

*1: Area in which a typical gain can be obtained.

*2: Please refer to the Silicon APD brochure for more detailed information.
Cap with micro-lens is available for small active area size.



info@amstechnologies.com
www.amstechnologies-webshop.com



Typ. Spectral Response ($T_A = 23^\circ\text{C}$, $M = 100$)

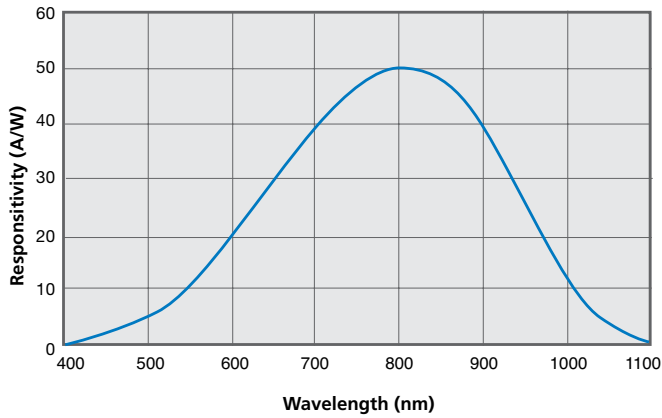

Typ. Quantum Efficiency vs. Wavelength ($T_A = 23^\circ\text{C}$)

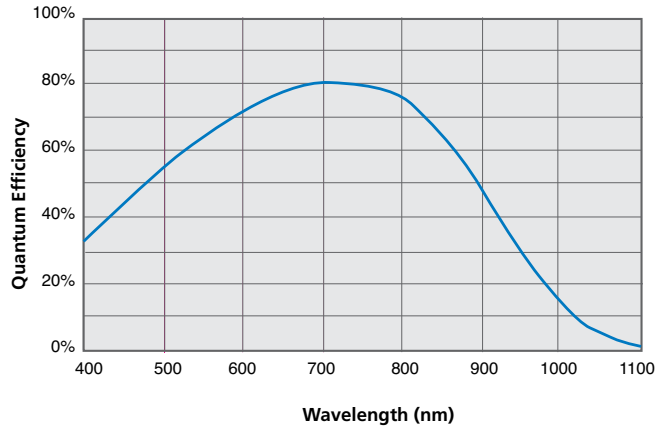

Typ. Dark Current vs. Reverse Bias ($T_A = 23^\circ\text{C}$)

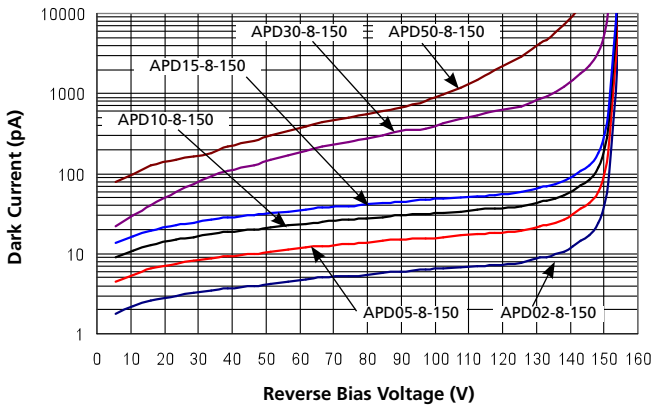

Typ. Gain vs. Reverse Bias ($T_A = 23^\circ\text{C}$, 800 nm)

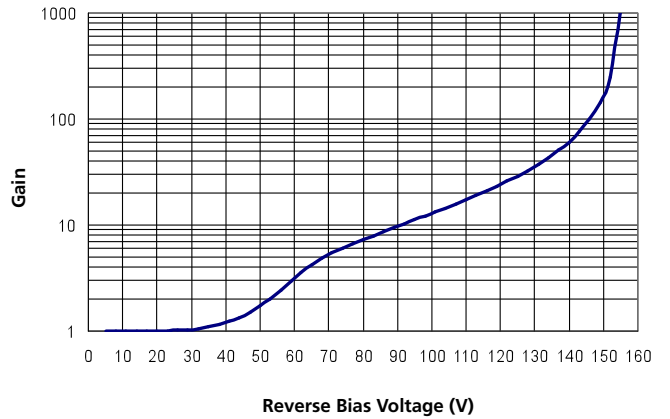

Typ. Capacitance vs. Reverse Bias ($T_A = 23^\circ\text{C}$, $f = 1\text{MHz}$)

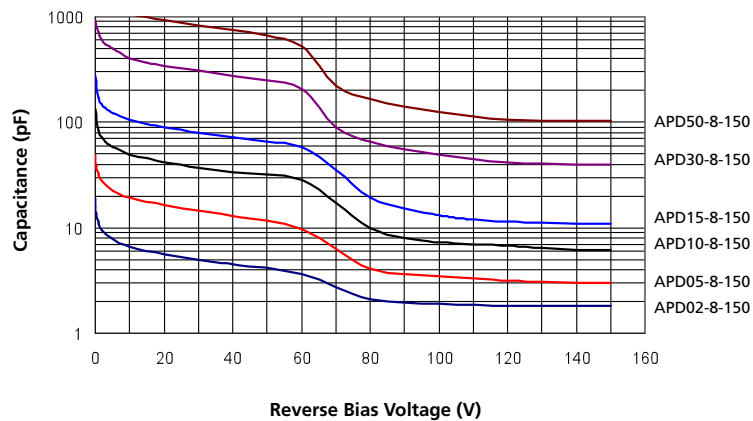

AVOID DIRECT LIGHT

Since the spectral response of silicon photodiode includes the visible light region, care must be taken to avoid photodiode exposure to high ambient light levels, particularly from tungsten sources or sunlight. During shipment from OSI Optoelectronics, your photodiodes are packaged in opaque, padded containers to avoid ambient light exposure and damage due to shock from dropping or jarring.

AVOID SHARP PHYSICAL SHOCK

Photodiodes can be rendered inoperable if dropped or sharply jarred. The wire bonds are delicate and can become separated from the photodiode's bonding pads when the detector is dropped or otherwise receives a sharp physical blow.

CLEAN WINDOWS WITH OPTICAL GRADE CLOTH / TISSUE

Most windows on OSI Optoelectronics photodiodes are either silicon or quartz. They should be cleaned with isopropyl alcohol and a soft (optical grade) pad.

OBSERVE STORAGE TEMPERATURES AND HUMIDITY LEVELS

Photodiode exposure to extreme high or low storage temperatures can affect the subsequent performance of a silicon photodiode. Storage temperature guidelines are presented in the photodiode performance specifications of this catalog. Please maintain a non-condensing environment for optimum performance and lifetime.

OBSERVE ELECTROSTATIC DISCHARGE (ESD) PRECAUTIONS

OSI Optoelectronics photodiodes, especially with IC devices (e.g. Photops) are considered ESD sensitive. The photodiodes are shipped in ESD protective packaging. When unpacking and using these products, anti-ESD precautions should be observed.

DO NOT EXPOSE PHOTODIODES TO HARSH CHEMICALS

Photodiode packages and/or operation may be impaired if exposed to CHLOROTHENE, THINNER, ACETONE, or TRICHLOROETHYLENE.

INSTALL WITH CARE

Most photodiodes in this catalog are provided with wire or pin leads for installation in circuit boards or sockets. Observe the soldering temperatures and conditions specified below:

Soldering Iron:	Soldering 30 W or less Temperature at tip of iron 300°C or lower.
Dip Soldering:	Bath Temperature: 260±5°C. Immersion Time: within 5 Sec. Soldering Time: within 3 Sec.
Vapor Phase Soldering:	DO NOT USE
Reflow Soldering:	DO NOT USE

Photodiodes in plastic packages should be given special care. Clear plastic packages are more sensitive to environmental stress than those of black plastic. Storing devices in high humidity can present problems when soldering. Since the rapid heating during soldering stresses the wire bonds and can cause wire to bonding pad separation, it is recommended that devices in plastic packages to be baked for 24 hours at 85°C.

The leads on the photodiode **SHOULD NOT BE FORMED**. If your application requires lead spacing modification, please contact OSI Optoelectronics Applications group at (310)978-0516 before forming a product's leads. Product warranties could be voided.



*Most of our standard catalog products are RoHS Compliant. Please contact us for details

Mechanical Drawings

Mechanical Specifications and Die Topography

1. Parameter Definitions:

A = Distance from top of chip to top of glass.

a = Photodiode Anode.

B = Distance from top of glass to bottom of case.

c = Photodiode Cathode

(Note: cathode is common to case in metal package products unless otherwise noted).

W = Window Diameter.

F.O.V. = Filed of View (see definition below).

2. Dimensions are in inches (1 inch = 25.4 mm).

3. Pin diameters are 0.018 ± 0.002 " unless otherwise specified.

4. Tolerances (unless otherwise noted)

General: $0.XX \pm 0.01$ "

$0.XXX \pm 0.005$ "

Chip Centering: ± 0.010 "

Dimension 'A': ± 0.015 "

5. Windows

All '**UV**' Enhanced products are provided with QUARTZ glass windows, 0.027 ± 0.002 " thick.

All '**XUV**' products are provided with removable windows.

All '**DLS**' PSD products are provided with A/R coated glass windows.

All '**FIL**' photoconductive and photovoltaic products are epoxy filled instead of glass windows.



$$F.O.V. = \tan^{-1} \left(\frac{W}{2A} \right)$$

For Further Assistance
Please Call One of Our Experienced
Sales and Applications Engineers

310-978-0516

OSI Optoelectronics
An OSI Systems Company

- Or -

visit our website at

www.osioptoelectronics.com

Mechanical Specifications

All units in inches. Pinouts are bottom view.

1 TO-18 2 TO-5 3 TO-8

Products:
PIN-020A
PIN-040A
PIN-040-DP/SB

Pin Circle Dia.=0.100

P/N	A	B	W
PIN-020A	0.075	0.200	0.155
PIN-040A	0.075	0.200	0.155

Products:
PIN-5DI
PIN-5DP
PIN-13DI
PIN-13DPI
PIN-5-YAG
CD-25T

Pin Circle Dia.=0.200

P/N	A	B	W
All Others	0.094	0.180	0.240
CD-25T	0.050	0.130	0.23

Products:
PIN-6DI
PIN-6DPI
PIN-44DI
PIN-44DPI
APD50-8-150-TO8

Pin Circle Dia.=0.295

P/N	A
PIN-6DI/6DPI	0.115
APD50-8-150-TO8	
PIN-44DI/44DPI	0.125
OSD35-0	0.130

4 TO-18 5 TO-5 6 TO-8

Products:
PIN-2DI
PIN-2DPI
PIN-3CDI
PIN-3CDP
PIN-3CDPI

Pin Circle Dia.=0.100

A	B
0.070	0.200
0.090	0.150

Products:
PIN-5D
PIN-5DP
PIN-5DP/SB
PIN-13D
PIN-13DP
PIN-005E-550F
UV-001
UV-005
UV-005DQ
UV-005EQ
UV-013DQ
UV-013EQ
UV-015
OSD-5-0
OSD15-0
OSD5-5T
OSD15-5T

Pin Circle Dia.=0.200

P/N	A	B
OSD-Prefix Devices	0.050	0.130
UV-XXXDQ	0.065	0.138
UV-XXXEQ	0.055	0.138
All Others	0.102	0.180

Quartz Window: OSD5.8-7Q
 UV Transmissive Window: OSD5.8-7U

Products:
PIN-6D
PIN-6DP
PIN-44D
PIN-44DP
UV-020
UV-035DQ
UV-035EQ
UV-035

Pin Circle Dia.=0.295

Dimensions		
P/N	A	B
UV-035DQ	0.130	0.195
UV-035EQ	0.120	0.195
All Others	0.140	0.205

7 TO-18 8 TO-18 9 TO-18

Products:
PIN-3CD
PIN-3CDP
BPX-65
OSD1-0
OSD1-5T
OSD3-5T
OSD1-E
OSD3-E

Pin Circle Dia.=0.100

P/N	A	B
PIN-3CD / 3CDP	0.087	0.146
BPX-65	0.075	0.200
OSD-Prefix Devices	0.080	0.200

Quartz Window: OSD1.2-7Q
 UV Transmissive Window: OSD1.2-7U

Products:
PIN-125DPL

Pin Circle Dia.=0.100

Products:
PIN-HR005
PIN-HR008
PIN-HR020
PIN-HR026
PIN-HR040

Pin Circle Dia.=0.100

Mechanical Specifications

All units in inches. Pinouts are bottom view.

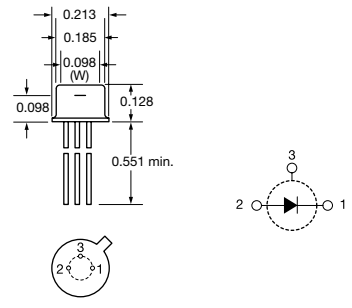
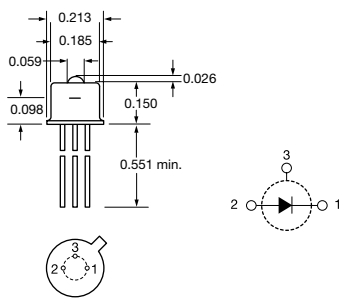
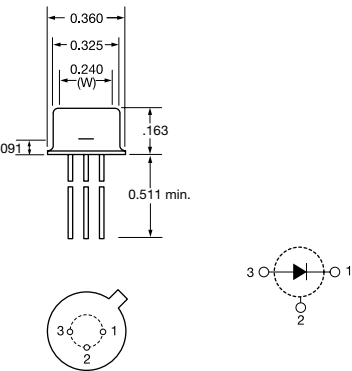
65 TO-52	66 TO-52L	67 TO-5
<p>Products: APD02-8-150-T52 APD05-8-150-T52 APD10-8-150-T52</p>  <p>Pin Circle Dia.=0.100</p>	<p>Products: APD02-8-150-T52L APD05-8-150-T52L APD10-8-150-T52L</p>  <p>Pin Circle Dia.=0.100</p>	<p>Products: APD15-8-150-TO5 APD30-8-150-TO5</p>  <p>Pin Circle Dia.=0.200</p>

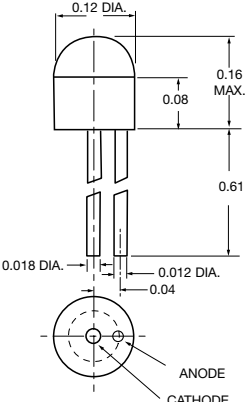
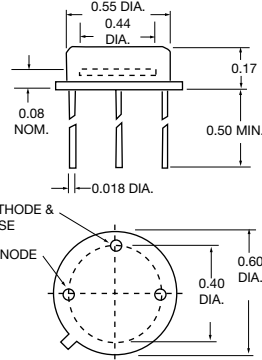
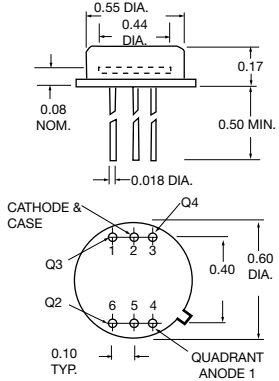
68 Plastic	69 TO-8	70 TO-8
<p>Products: CD-1705</p>  <p>ANODE CATHODE</p>	<p>Products: OSD60-0 OSD60-ST OSD60-E</p>  <p>CATHODE & CASE ANODE</p>	<p>Products: QD50-0</p>  <p>CATHODE & CASE Q4 Q3 Q2 Q1 QUADRANT ANODE 1</p>

Distributor



amstechnologies
where technologies meet solutions

info@amstechnologies.com
www.amstechnologies-webshop.com

Contact us 