

Type MX Precision High Voltage Resistors

For Replacements see the RoHS Compliant Models MX531, MX540, MX550, MX580, and MX585

Cost Effective High Voltage Resistors for Industrial and General Purpose Applications

The Type MX Precision High Voltage Resistors were specifically developed for use in industrial and general purpose high voltage systems. These resistors combine the proven performance of Caddock's Micronox[®] resistance system with new cost efficient design elements. These resistors are intended for the design of high voltage systems where the system is not exposed to full military or space grade operating conditions. For full military or space grade operating conditions, we recommend Caddock's **Type TG Low TC Precision High Voltage Resistors** or **Type MG Precision High Voltage Resistors**.

The performance features of the Type MX Precision High Voltage Resistors are:

- Five Models with Voltage Ratings from 7.5 KV to 32 KV.
- Temperature Coefficient: 80 ppm/°C from 0°C to +70°C.
- Load Life Stability of 0.50% per 1,000 hours.
- Resistance Tolerance: 1% Standard.
- Non-Inductive Design.
- Resistance Range from 1 Megohm to 1,000 Megohms.

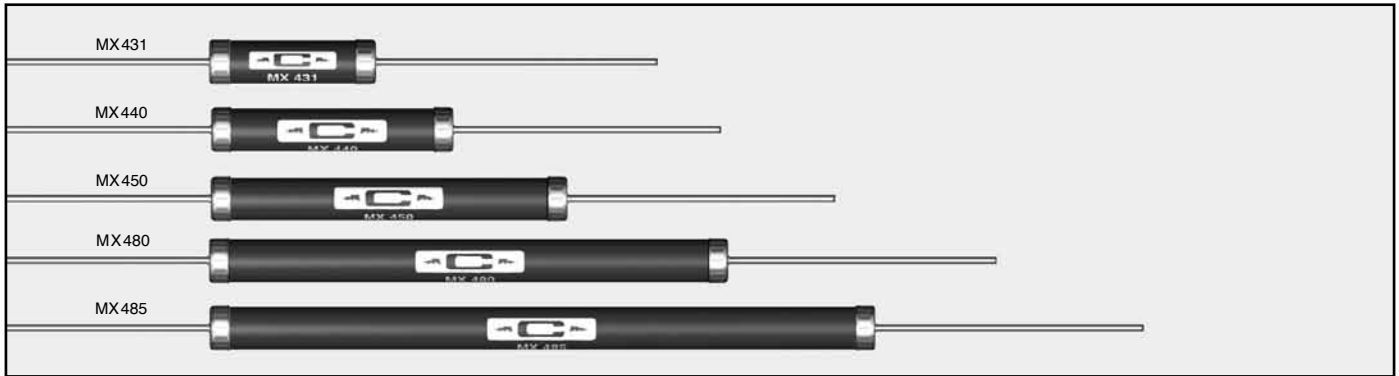

Model No.	Watt-age	Max. Continuous Oper. Volt.	TC ppm/°C	Resistance		Dimensions in inches and (millimeters)		
				Min.	Max.	A	B	C
MX431	2.0	7,500	80	1 Meg	150 Meg	.940 ±.040 (23.88 ±1.02)	.270 ±.020 (6.86 ±.51)	.040 ±.002 (1.02 ±.05)
MX440	3.5	11,000	80	1.5 Meg	300 Meg	1.450 ±.040 (36.83 ±1.02)	.270 ±.020 (6.86 ±.51)	.040 ±.002 (1.02 ±.05)
MX450	5.0	16,000	80	2 Meg	500 Meg	2.080 ±.040 (52.83 ±1.02)	.270 ±.020 (6.86 ±.51)	.040 ±.002 (1.02 ±.05)
MX480	7.5	24,000	80	3 Meg	750 Meg	3.080 ±.050 (78.23 ±1.27)	.270 ±.020 (6.86 ±.51)	.040 ±.002 (1.02 ±.05)
MX485	10.0	32,000	80	4 Meg	1,000 Meg	3.940 ±.050 (100.08 ±1.27)	.270 ±.020 (6.86 ±.51)	.040 ±.002 (1.02 ±.05)

Standard Resistance Values:

- 1% tolerance standard
- | | | | |
|----------|----------|---------|----------|
| 1.00 Meg | 10.0 Meg | 100 Meg | 1000 Meg |
| 2.00 Meg | 20.0 Meg | 200 Meg | |
| 2.50 Meg | 25.0 Meg | 250 Meg | |
| 5.00 Meg | 50.0 Meg | 500 Meg | |

Non-standard (custom) resistance values are available. Please contact Caddock Applications Engineering.

Specifications:

Temperature Coefficient: 80 ppm/°C referenced to +25°C, ΔR taken at 0°C and +70°C.

Thermal Shock: Mil-Std-202, Method 107, Cond. A, ΔR, 0.20% max.

Moisture Resistance: Mil-Std-202, Method 106, ΔR, 1.0% max.

Load Life: 1,000 hours at rated voltage at +70°C, not to exceed rated power, ΔR, 0.50% max.

Lead Material: Tinned copper clad steel, solderable.

Encapsulation: Screen printed high temperature silicone coating over resistor element.

Type MX Resistors Utilize Caddock's Patented Coating Design

Type MX Precision High Voltage Resistors combine Caddock's Non-Inductive serpentine pattern with a patented, high thru-put screen printed silicone coating. The alignment of the gap in the coating pattern with the gap in the serpentine resistor pattern provides a complete encapsulation of the resistor element. The cap and lead assemblies are pressed onto the resistor core, finishing the resistor and providing rugged terminal attachment.

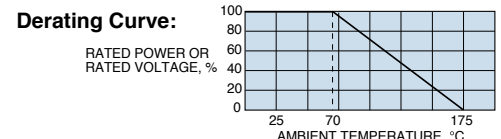
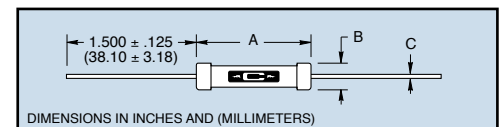
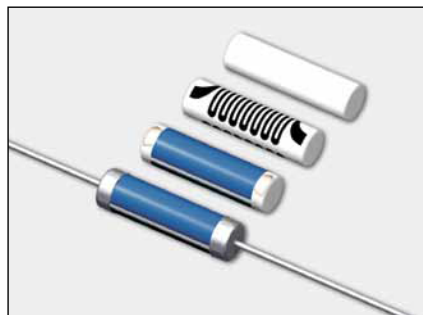

Ordering Information:

Model Number: **MX485** - **100M** - **1%** Tolerance
Resistor Value: _____