

# EYP-RWS-0780-00080-1500-TOV01-0000

Revision 0.90

2025-04-08

## SINGLE FREQUENCY LASER DFB Laser



### General Product Information

Product	Application
780 nm Wavelength Stabilized Laser	Metrology
with hermetic 8-Pin TO Package (RoHS compliant)	Interferometry
including Monitor Diode, Thermoelectric Cooler and Thermistor	

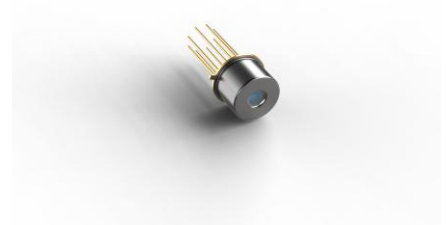

### Absolute Maximum Ratings

Parameter	Symbol	Unit	min	typ	max
Storage Temperature	$T_S$	°C	-40		85
Operational Temperature at Case	$T_C$	°C	-20		75
Operational Temperature at Chip	$T_{chip}$	°C	5		50
Forward Current	$I_F$	mA			200
Reverse Voltage	$V_R$	V			2
Output Power	$P_{opt}$	mW			100
TEC Current	$I_{TEC}$	A			1.0
TEC Voltage	$V_{TEC}$	V			1.0

### Measurement Conditions / Comments

Stress in excess of one of the Absolute Maximum Ratings may damage the laser. Please note that a damaging optical power level may occur although the maximum current is not reached. These are stress ratings only, and functional operation at these or any other conditions beyond those indicated under Recommended Operational Conditions is not implied.

### Recommended Operational Conditions

Parameter	Symbol	Unit	min	typ	max
Operational Temperature at Case	$T_{case}$	°C	-20		65
Operational Temperature at Chip	$T_{chip}$	°C	15		45
Forward Current	$I_F$	mA			180
Output Power	$P_{opt}$	mW	20		80

### Measurement Conditions / Comments

measured by integrated Thermistor

# EYP-RWS-0780-00080-1500-TOV01-0000

Revision 0.90

2025-04-08

## SINGLE FREQUENCY LASER DFB Laser



### Characteristics Tchip = 25 °C at BOL

Parameter	Symbol	Unit	min	typ	max
Center Wavelength	$\lambda_c$	nm	778	780	783
Linewidth	$\Delta\lambda$				
Sidemode Suppression Ratio	SMSR	dB	30	45	
Temp. Coefficient of Wavelength	$d\lambda / dT$	nm/K		0.06	
Current Coefficient of Wavelength	$d\lambda / dI$	nm/mA		0.003	
Laser Current	$I_{LD}$	mA			180
Slope Efficiency	$\eta$	mW/mA		1.0	
Threshold Current	$I_{th}$	mA			70
Divergence parallel	$\Theta_{  }$	°		8	
Divergence perpendicular	$\Theta_{\perp}$	°		21	
Degree of Polarization	DOP	%		90	

### Measurement Conditions / Comments

FWHM: Popt = 80 mW  
under single mode condition

parallel to Pin 1 - Pin 6 plane (see p. 3)  
perpendicular to Pin 1 - Pin 6 plane (see p. 3)  
Popt = 80 mW; E field perpendicular to Pin 1 - 6 plane

### Monitor Diode

Parameter	Symbol	Unit	min	typ	max
Monitor Detector Responsivity	$I_{mon} / P_{of}$	$\mu A/mW$	0.3		100

Measurement Conditions / Comments  
5 V

### Thermoelectric Cooler

Parameter	Symbol	Unit	min	typ	max
Current	$I_{TEC}$	A		0.4	
Voltage	$U_{TEC}$	V		0.4	
Power Dissipation (total loss at case)	$P_{loss}$	W		0.4	
Temperature Difference	$\Delta T$	K			40

Measurement Conditions / Comments  
Popt = 80 mW,  $\Delta T = 20$  K  
Popt = 80 mW,  $\Delta T = 20$  K  
Popt = 80 mW,  $\Delta T = 20$  K  
Popt = 80 mW,  $\Delta T = |T_{case} - T_{chip}|$

### Thermistor (Standard NTC Type)

Parameter	Symbol	Unit	min	typ	max
Resistance	R	k $\Omega$		10	
Beta Coefficient	b			3952	
Steinhart & Hart Coefficient A	A			$9.531 \times 10^{-4}$	
Steinhart & Hart Coefficient B	B			$2.644 \times 10^{-4}$	
Steinhart & Hart Coefficient C	C			$-4.356 \times 10^{-8}$	

Measurement Conditions / Comments  
Tchip = 25 °C  
 $R_1/R_2 = e^{b(1/T_1 - 1/T_2)}$  at Tchip = 0 ... 50 °C  
 $1/T = A + B(\ln R) + C(\ln R)^3$   
T: Temperature in Kelvin  
R: resistance at T in  $\Omega$

# EYP-RWS-0780-00080-1500-TOV01-0000

Revision 0.90

2025-04-08

## SINGLE FREQUENCY LASER DFB Laser



### Pin Assignment

1 Laser Diode Anode	5 Thermistor
2 Laser Diode Cathode	6 Thermistor
3 Thermoelectric Cooler (-)	7 Photo Diode Anode
4 Thermoelectric Cooler (+)	8 Photo Diode Cathode

All 8 pins are isolated from case.

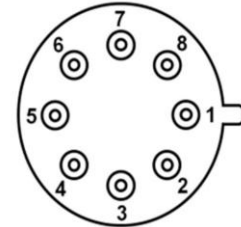

bottom view

### Package Drawings

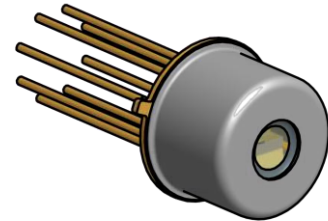
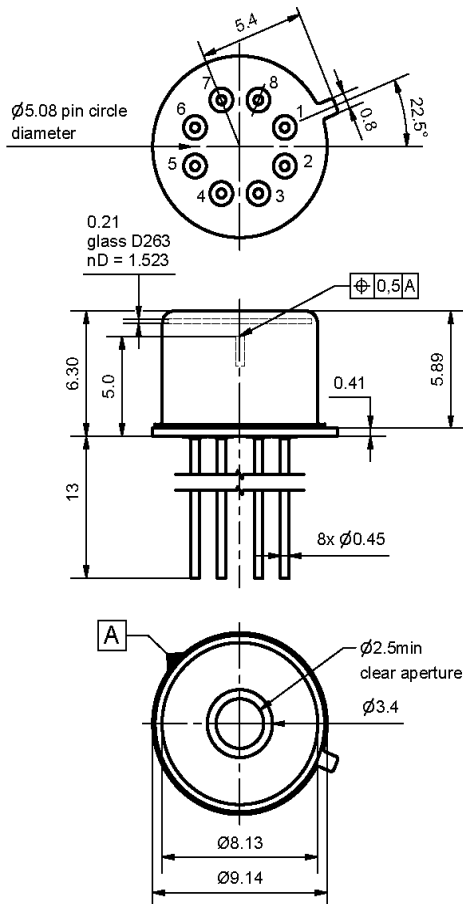

AIZ-19-0129-1426C

# EYP-RWS-0780-00080-1500-TOV01-0000

Revision 0.90

2025-04-08

## SINGLE FREQUENCY LASER DFB Laser



### Unpacking, Installation and Laser Safety

Unpacking the laser diodes should only be done at electrostatic safe workstations (EPA). Though protection against electro static discharge (ESD) is implemented in the laser package, charges may occur at surfaces. Please store this product in its original package at a dry, clean place until final use. During device installation, ESD protection has to be maintained.

A laser diode is sensitive against optical feedback, so an optical isolator may be required in order to avoid any disturbance of the emission spectrum. Operating at moderate temperatures on proper heat sinks will contribute to a long lifetime of the diode.

Avoid direct and/or indirect exposure to the free running beam. Collimating and focussing the free running beam with optics as common in optical instruments will increase threat to the human eye.

Each laser diode will come with an individual test protocol verifying the parameters given in this document.

Performance figures, data and any illustrative material provided in this specification are typical and must be specifically confirmed in writing by eagleyard Photonics before they become applicable to any particular order or contract. In accordance with the eagleyard Photonics policy of continuous improvement specifications may change without notice.

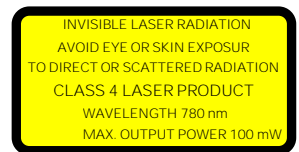

IEC-60825-1



Complies with 21 CFR 1040.10 and 1040.40