

High-Sensitivity USB2.0 Color 8/12-Bit 1.4MP 2/3" CCD Camera with Frame Buffers (Part Numbers: CXN-C013-U, CXE-C013-U)

FEATURES

- Built-in frame buffer (8 frames at full resolution)
- Support multi-camera applications
- 4-pin GPIOs
- 1,392 x 1,040 active pixels
- Ultra compact
- High-speed USB2.0 (480Mb/s)
- Digital output, no need for frame grabber
- Full-featured SDK
- Compatible with Windows 2000, XP, Vista, Windows 7 and 8
- TWAIN driver
- USB protocol for non-Windows based applications
- External and Software trigger
- Strobe output for external flash
- ROI & pixel skipping/binning
- No need for external power supply
- OEM versions available

APPLICATIONS

- Digital microscopy
- Machine vision
- Fluorescence imaging
- Medical imaging
- Semiconductor equipment
- Test instruments
- Document scanners
- 2D barcode readers
- High-quality ID photos
- Security camera
- Astrophotography



PRODUCT DESCRIPTION

Mightex USB 2.0 CCD cameras with frame buffers are optimized for machine-vision applications, and they can also be used for a wide variety of other applications such as digital microscopy and medical imaging, where quality, ease of use, and cost-effectiveness are crucial. These cameras have built-in frame buffers, external trigger-in, strobe-out, and a powerful camera engine that supports multiple cameras. Frame rate can be as high as 15 fps in full resolution and up to 80 fps using ROI mode. In addition, a user-friendly GUI based application software and an SDK are provided for custom software development. A USB command set protocol is also provided for non-Windows based applications.

PERFORMANCE SPECIFICATIONS

Parameters	CXN-C013-U	CXE-C013-U	Unit
Board-level / enclosed	Board-level	Enclosed	
Number of GPIOs	4	4	
Resolution	1,392 x 1,040 Color		
Bit	8/12		bits
CCD Chip	2/3" Sony ICX285AQ, Global shutter		
Pixel Size	6.45 x 6.45		μm
Active Imager Size	Diagonal 11.0		mm
Scanning System	Progressive		
Frame Rates* (@28MHz Clock)	15 @1,392 x 1,040 49 @348 x 256 (1:4 Skip)		fps
Sub Resolutions	348 x 256 (1:4 Skip)		
Shutter Speed (Exposure time)	0.05 ~ 200,000		ms
Hardware Gains	6 ~ 43		dB
Trigger Mode	With external trigger**		
Trigger Delay	< 25		μs
Strobe Out	Yes		
Lens Mount	C- mount or CS-mount		
Built-in Filters	IR-cut (factory standard), no filter, or IR-pass		
Power Consumption	< 1.8		W
Dimension	89 x 64 x 34 (CS-mount) 89 x 64 x 39 (C-mount)	95 x 70 x 38.5 (CS-mount) 95 x 70 x 43.5 (C-mount)	mm
Weight (excluding lens)	80	150	g

* The actual achievable frame rate depends on exposure time, as well as available resources of PC system.

** Part number of the trigger cable for external trigger : ACC-CAM-DIN8

High-Sensitivity USB2.0 Monochrome 8/12-Bit 1.4MP 2/3" CCD Camera with Frame Buffers (Part Numbers: CXN-B013-U, CXE-B013-U)

FEATURES

- Built-in frame buffer (8 frames at full resolution)
- Support multi-camera applications
- 4-pin GPIOs
- Higher sensitivity than color cameras
- 1,392 x 1,040 active pixels
- Ultra compact
- High-speed USB2.0 (480Mb/s)
- Digital output, no need for frame grabber
- Full-featured SDK
- Compatible with Windows 2000, XP, Vista, Windows 7 and 8
- TWIN driver
- USB protocol for non-Windows based applications
- External and Software trigger
- Strobe output for external flash
- ROI & pixel skipping/binning
- No need for external power supply
- OEM versions available

APPLICATIONS

- Digital microscopy
- Fluorescence imaging
- Machine vision
- Medical imaging
- Semiconductor equipment
- Test instruments
- High-quality ID photo capture
- Document scanners
- 2D barcode readers
- Security camera
- Astrophotography



PRODUCT DESCRIPTION

Mightex USB 2.0 CCD cameras with frame buffers are optimized for machine-vision applications, and they can also be used for a wide variety of other applications such as digital microscopy and medical imaging, where quality, ease of use, and cost-effectiveness are crucial. These cameras have built-in frame buffers, external trigger-in, strobe-out, and a powerful camera engine that supports multiple cameras. Monochrome cameras often exhibit 20% higher spatial resolution than their color counterparts because no pixel interpolation is necessary. Without a Bayer color filter on the sensor, monochrome cameras are also more sensitive than color sensors especially in near IR and UV regions. Frame rate can be as high as 15 fps in full resolution and up to 80 fps using ROI mode. In addition, a user-friendly GUI based application software and an SDK are provided for custom software development. A USB command set protocol is also provided for non-Windows based applications.

PERFORMANCE SPECIFICATIONS

Parameters	CXN-B013-U	CXE-B013-U	Unit
Board-level / enclosed	Board-level	Enclosed	
Number of GPIOs	4	4	
Resolution	1,392 x 1,040 Monochrome		
Bit	8/12		bits
CCD Chip	2/3" Sony ICX285AL, Global shutter		
Pixel Size	6.45 x 6.45		µm
Active Imager Size	Diagonal 11.0		mm
Scanning System	Progressive		
Frame Rates* (@28MHz Clock)	15 @1,392 x 1,040 29 @696 x 520 (2 x 2 Bin) 37 @464 x 344 (3 x 3 Bin) 49 @348 x 256 (4 x 4 Bin) 49 @348 x 256 (1:4 Skip)		fps
Sub Resolutions	696 x 520(2 x 2 Bin), 464 x 344 (3 x 3 Bin), 348 x 256 (4 x 4 Bin), 348 x 256 (1:4 Skip)		
Shutter Speed (Exposure time)	0.05 ~ 200,000		ms
Hardware Gains	6 ~ 43		dB
Trigger Mode	With external trigger		
Trigger Cable	ACC-CAM-DIN8		
Trigger Delay	< 25		µs
Strobe Out	Yes		
Lens Mount	C- mount or CS-mount		
Built-in Filters	IR-cut (factory standard), no filter, or IR-pass		
Power Consumption	< 1.8		W
Dimension	89 x 64 x 34 (CS-mount) 89 x 64 x 39 (C-mount)	95 x 70 x 38.5 (CS-mount) 95 x 70 x 43.5 (C-mount)	mm
Weight (excluding lens)	80	150	g

* The actual achievable frame rate depends on exposure time, as well as available resources of PC system.

C-Series 1.4MP 2/3" CCD Cameras

OPERATION CONDITION

Operating Temperature Range:	0°C ~ 45°C
Storage Temperature Range:	-25°C ~ 85°C
Relative Humidity, Non-condensing:	5% ~ 95%

RECOMMENDED SYSTEM CONFIGURATION

Processor:	Pentium III 900 MHz or better, or a compatible processor
Operating System:	Windows 2000, XP, Vista, Windows 7 AND 8
RAM:	256MB or greater
Hard Disk Space:	30MB for software installation, plus additional space for storing captured images
USB2.0 Host Controller:	Intel integrated host controller (recommended)

EXAMPLE OF GRAPHICAL USER INTERFACE



Distributor



info@amstechnologies.com
www.amstechnologies-webshop.com

Contact us 



INSTALLATION DRAWINGS

Enclosed camera with CS-mount

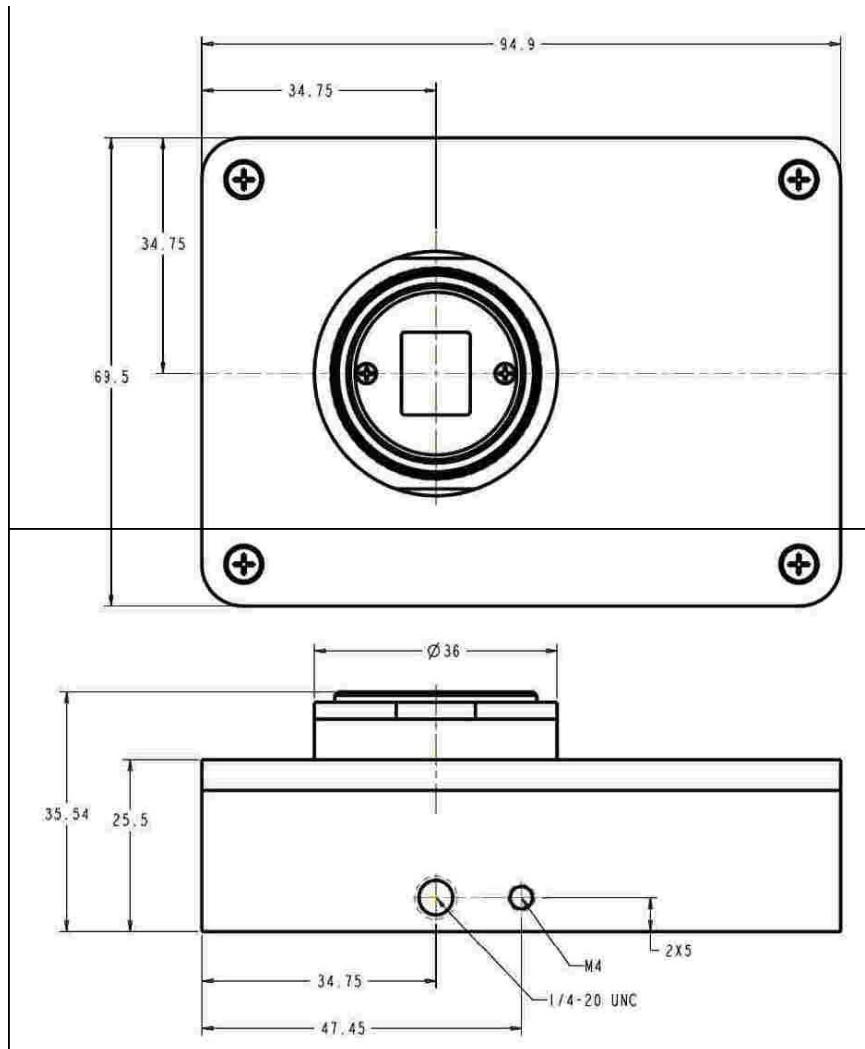

Distributor



amstechnologies
where technologies meet solutions

info@amstechnologies.com
www.amstechnologies-webshop.com

Contact us 

WHAT'S IN A C-MOUNT CAMERA?

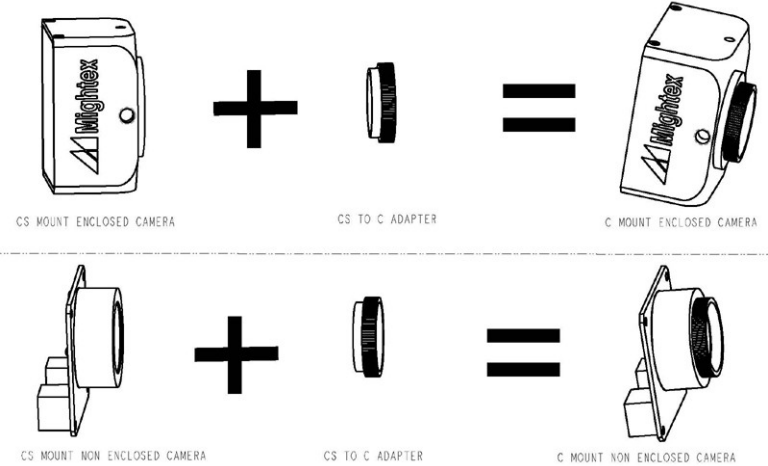

A C-mount camera is composed of a CS-mount camera and a CS-to-C-mount adapter. The latter is essentially a 5mm thick threaded ring.

With a world-class OEM design team, Mightex offers a broad range of customized solutions in order to meet individual customer's unique requirements. Please call 1-416-840 4991 or email sales@mightex.com for details.

Distributor



amstechnologies
where technologies meet solutions

info@amstechnologies.com
www.amstechnologies-webshop.com

Contact us 