

## Lead Selenide Plate Cells Series F-FA-FS Hermetically Sealed Series FM-FAM-FSM

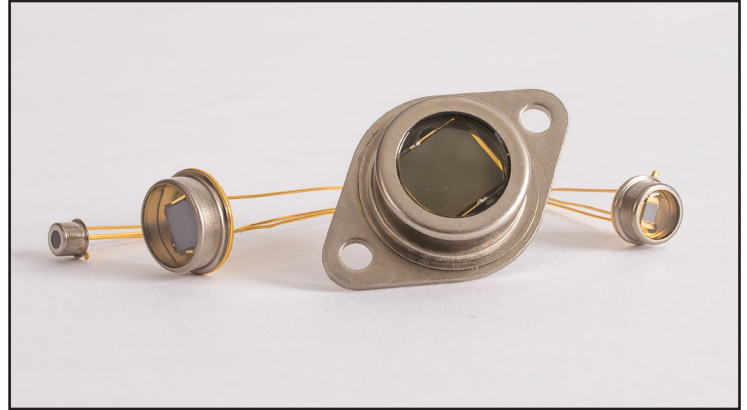

### FEATURES:

- Hermetically Sealed Packages
- Room Temperature Operation
- Custom Wavelength Response
- Custom Test Procedure
- Hybrid Amplifiers
- 2 Year Warranty
- Customized Filters Available
- Custom Packages

### HOW TO ORDER:

Select the proper electrical type: (F, FM), and match it with the proper mechanical and package code number. Example: FM-1-5, FM-5-8. The active areas listed are considered standard sizes. Special sizes are available upon request.

### Electrical Specifications

| Test Conditions at 25°C - Typical  | F & FM  | FA & FAM | FS & FSM |
|------------------------------------|---------|----------|----------|
| D* (Pk., 1000,1) x 10 <sup>9</sup> | 2-4     | 5-7      | >8       |
| Wavelength Cut-off - Microns       | 4.5-5.0 | 4.5-5.0  | 4.5-5.0  |
| Peak Wavelength Response - Microns | 3.8-4.3 | 3.8-4.3  | 3.8-4.3  |
| Time Constant - μSeconds           | 3-5     | 3-5      | 3-5      |
| Resistance - Megohms               | 0.1-4   | 0.1-4    | 0.1-4    |

### Active Area Specifications

| Code Number | Active Area   |         | Bias Voltage Range |         | Typical VW-1 Responsivity | Package Size |
|-------------|---------------|---------|--------------------|---------|---------------------------|--------------|
|             | Inches        | MM      | Minimum            | Maximum |                           |              |
| 1           | 0.040 x 0.040 | 1 x 1   | 1                  | 100     | 6,000                     | TO-5 - TO-46 |
| 2           | 0.080 x 0.080 | 2 x 2   | 1                  | 200     | 3,000                     | TO-5         |
| 3           | 0.120 x 0.120 | 3 x 3   | 1                  | 300     | 2,000                     | TO-5         |
| 5           | 0.200 x 0.200 | 5 x 5   | 1                  | 500     | 1,200                     | TO-8         |
| 10          | 0.400 x 0.400 | 10 x 10 | 1                  | 1000    | 600                       | TO-3         |

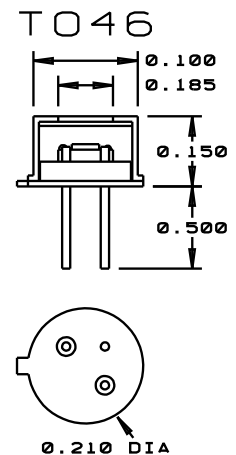
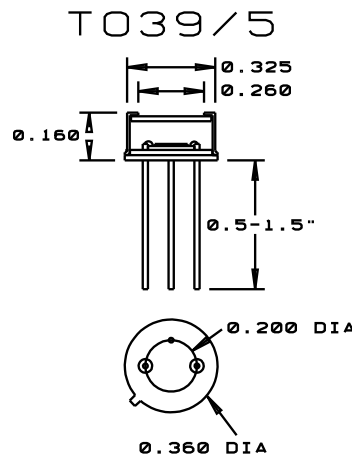
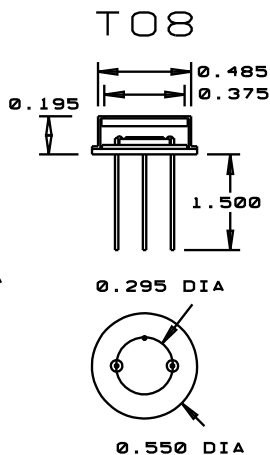
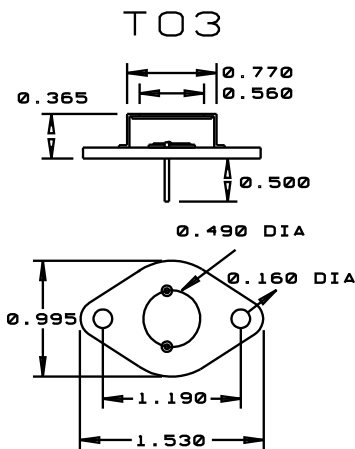

## Ordering Information

| Series Code | Description - Lead Sulfide (PbS) | Series Code | Description - Lead Sulfide (PbS)     |
|-------------|----------------------------------|-------------|--------------------------------------|
| A           | Plate Cell                       | F           | Plate Cell                           |
| B           | Plate Cell                       | FA          | Plate Cell, Medium Performance       |
| C           | Plate Cell                       | FS          | Plate Cell, High Performance         |
| AM          | Type A, Hermetic Package         | FM          | Hermetic Package                     |
| BM          | Type B, Hermetic Package         | FAM         | Hermetic Package, Medium Performance |
| CM          | Type C, Hermetic Package         | FSM         | Hermetic Package, High Performance   |
| D           | 1-stage TE cooled -20 C          | G           | 1-stage TE cooled -20 C              |
| D2          | 2-stage TE cooled -30 C          | G2          | 2-stage TE cooled -30 C              |
| D21         | 2-stage TE cooled - 45 C         | G21         | 2-stage TE cooled -45 C              |

## Size and Package Codes

| Size Code | Description             | Package Code | Description                           |
|-----------|-------------------------|--------------|---------------------------------------|
| 25        | .25 mm sq. - 0.010" SQ  | 5-46-8-66-37 | TO-5, TO-46, TO-8, TO-66, TO-37, TO-3 |
| 50        | .50 mm sq. - 0.020" SQ  | 5-46-8-66-37 | TO-5, TO-46, TO-8, TO-66, TO-37, TO-3 |
| 1         | 1.0 mm sq. - 0.040" SQ  | 5-46-8-66-37 | TO-5, TO-46, TO-8, TO-66, TO-37, TO-3 |
| 2         | 2.0 mm sq. - 0.080" SQ  | 5-8-66-37    | TO-5, TO-8, TO-66, TO-37, TO-3        |
| 3         | 3.0 mm sq. - 0.120" SQ  | 5-8-66-37    | TO-5, TO-8, TO-66, TO-37, TO-3        |
| 5         | 5.0 mm sq. - 0.200" SQ  | 8-66-3       | TO-3, TO-8, TO-66                     |
| 6         | 6.0 mm sq. - 0.240" SQ  | 3            | TO-3                                  |
| 10        | 10.0 mm sq. - 0.400" SQ | 3            | TO-3                                  |

Other sizes and geometrics available. See Page 8 for Package Dimensions.

Liquid Nitrogen Dewars Available: D=Down Looking and S=Side Looking

Contact NEP or Visit our web site for more details

## Examples

|         |  |
|---------|--|
| B-1     | Lead Sulfide 1x1 mm plate cell   |
| CM-5-8  | Lead Sulfide 5x5 mm detector, in a TO-8 package, hermetically sealed     |
| FM-3-5  | Lead Selenide 3x3 mm detector, in a TO-5 package, hermetically sealed    |
| D21-5-8 | Lead Sulfide 5x5 mm detector with a 2-stage TE cooler, in a TO-8 package |
| NOTE:   | TE cooled devices include thermistor: please add "C" for calibration     |
| Arrays  | Please contact NEP for array and multiplexed array orders                |

Response

Charts

PbSe  
LEAD SULFIDE

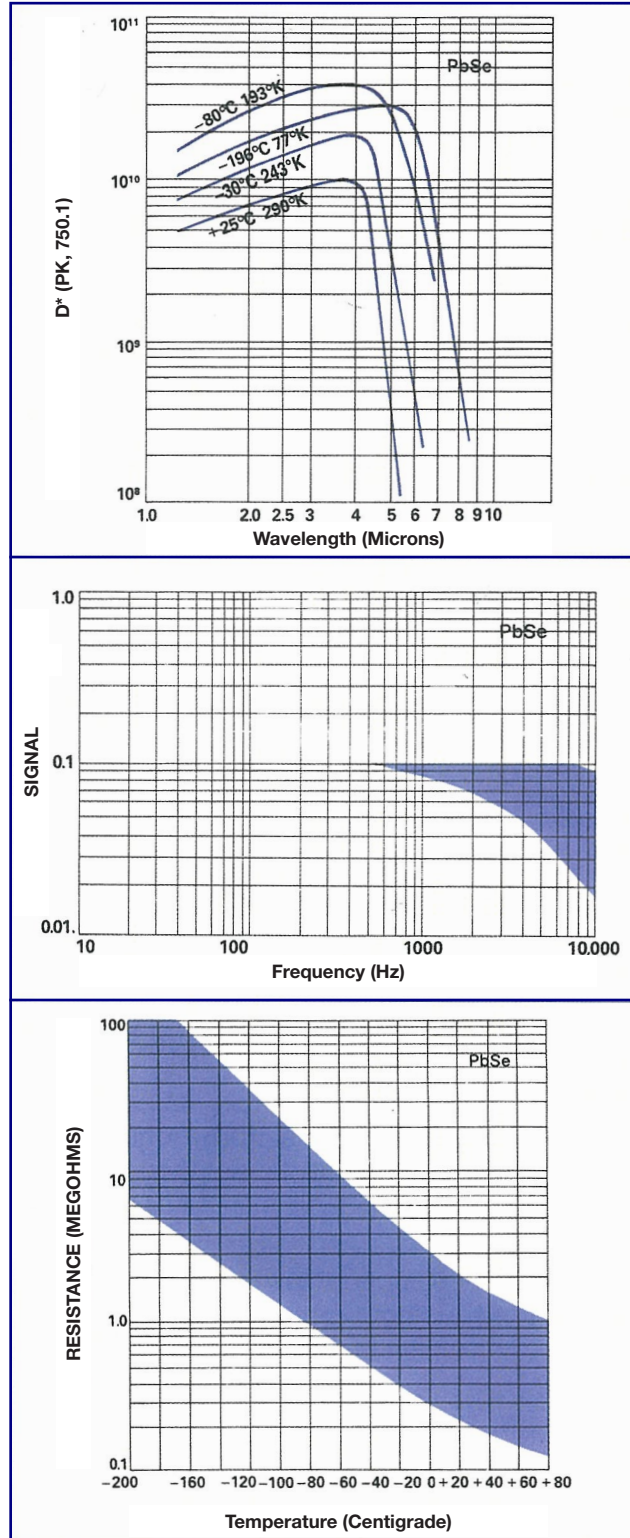

## Detector Performance Terminology

### Photoconductive Detector

A photon detector which exhibits increased conductivity with incident radiant power.

### Photovoltaic Detector

A photon detector with a p-n or p-i-n junction which converts radiant power directly into electrical current; also called a photodiode.

### D-Star ( $D^*$ )

A relative measure of sensitivity used to compare the detecting capabilities of different detectors.  $D^*$  is the signal-to-noise ratio at a specific electrical frequency with 1 Hz bandwidth when radiant power is incident on the detector active area.

### Responsivity

A value indicating signal output from radiation incident on the detector element. The value where the detector has a maximum spectral response is called peak responsivity. It is a function of detector area, wavelength and circuit parameters.

### Noise-Equivalent-Power (NEP)

The amount of required signal radiant power on the detector element area to yield a signal-to-noise ratio of one, and indicates the minimum detectable radiation level; the smaller the NEP value, the better the performance.

### Resistivity

The square areas resistance of a thin film detector, where L and W are equal; L being the separation between the electrodes and W is the length of the detector area. Resistivity is a function of the detector element temperature and the level of irradiance.

### RMS Signal Voltage or Current

The element of the electrical output (voltage or current) which is coherent with the monochromatic or blackbody input signal radiant power. It is a function of electrical frequency, signal power, spectral characteristics, operating temperature, and other circuit parameters such as the load resistor and bias voltage.

### RMS Noise Voltage or Current

The element of the electrical output (voltage or current) which is incoherent with the signal radiant power, usually measured with no signal radiation incident on the detector element and is related to the detector area. It is the function of frequency response, noise equivalent bandwidth, operating temperature, other circuit parameters such as load resistor, and in some cases, detector solid angle and background temperature.

### Dark Resistance

The ratio of the DC voltage across the detector to the DC current through it when no radiation is incident on the detector.

### Dark Current

The measured current in a detector circuit when operated with no signal radiation incident on the detector element.

### Bias Voltage

The voltage applied to the detector circuit, normally DC volts; sometimes called optimum bias for values which give optimum signal-to-noise ratios and maximum bias for values which product the maximum signal voltage output; it is called reverse bias when applied to the P-N junction of solid crystal detectors in a reverse mode to increase the speed of response or to increase the long wavelength response..

### Background Temperature

The effective temperature of all radiation sources viewed by the detector, excluding the signal source.

### Spectral Response

Most of the time, this is shown as  $D^*$  vs Wavelength; usually presented as a graph showing relative signal as a function of wavelength of the incident of radiant power.

### Load Resistor

A resistance element that is in a series with the detector element and bias voltage; typically matched to the detector's dark resistance.

### Open Circuit Voltage

A DC voltage produced by a photo voltaic detector when connected to a high impedance load.

### Time Constant

A measurement of a detector's speed of response when the detector is exposed to a square-wave pulse of radiation. the rise time constant is the time required for the signal voltage to reach 0.63 times its asymptotic value. The decay time constant is the time required fr the signal voltage to decay to 0.37 of the asymptotic value. This can also be measured by determining the chopping frequency at which the signal response id 0.707 of its maximum value.

### Rise Time - Fall Time

Rise time and fall time are the times in seconds required for the signal response to rise from 10% to 90% and fall from 90% to 10% of the maximum observed signal value. This happens when detectors are exposed to pulses of signal radiant power..

### Cut-off Wavelength

The long wavelength point where the detector responsivity has degraded to a specific percent of the peak responsivity; usually 20% or 50% of the peak responsivity.



**Distributor**

**amSTECHNOLOGIES**

where technologies meet solutions

info@amstechnologies.com  
www.amstechnologies-webshop.com

**Contact us**

