

# STG / STV / STU High Performances Green & UV Triggered Microchip Series

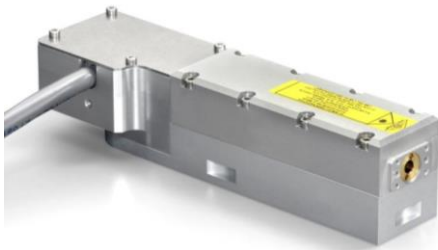

## KEY FEATURES

- Ultra-short pulses down to 350ps
- 532nm, 355nm and 266nm
- Single-shot to 100kHz
- Multi-kW peak power
- Excellent beam quality
- Efficient, air-cooled
- Sealed package, extremely long life

For generating high peak power pulses of a few hundred picoseconds, microchip lasers are economical, compact, and reliable. Visible and UV wavelength are generated from the harmonic conversion of an IR passively Q-switched Nd:YAG microchip engine, within a sealed package ensuring incredibly long lifetime even in harsh industrial environment.

The triggered series offer the highest peak power and shortest pulses of the entire Microchip family, and span the full wavelength spectrum down to 266nm. With these devices, the user is able to trigger pulse emission on demand from single-shot to 4kHz.

## APPLICATIONS

- Instrumentation
  - Ranging
  - Differential absorption LIDAR
  - Super-continuum generation
  - Distributed temperature sensing
  - Raman spectroscopy
- Biophotonics
  - Micro-dissection of cells
  - Brain nanosurgery
  - Protein cross-linking



**amSTECHNOLOGIES**  
where technologies meet solutions

info@amstechnologies.com  
www.amstechnologies-webshop.com

**Contact us** 

	STG-03E-1x0	STG-05E-1x0	STV-01E-1x0	STV-02E-1x0 <sup>(9)</sup>	STU-01E-1x0
<b>Wavelength</b>	532nm	532nm	355nm	355nm	266nm
<b>Maximum Repetition Rate</b> $RR_{max}^{(1)}$	4 kHz	1 kHz	4 kHz	4 kHz	4 kHz
<b>Constant Pulse width (FWHM)</b> <sup>(2)</sup>	<0.5ns	<0.7ns	<0.4ns	<0.6ns	<0.4ns
<b>Output Energy</b>	>3 $\mu$ J	>5 $\mu$ J	>1 $\mu$ J	>2 $\mu$ J	>1 $\mu$ J
<b>Peak Power</b>	>6kW	>7.1kW	>2.5kW	>4kW	>2kW
<b>PCD</b> <sup>(3)</sup>	<70 $\mu$ s	<70 $\mu$ s	<100 $\mu$ s	<100 $\mu$ s	<100 $\mu$ s
<b>PCD jitter</b>	< $\pm$ 1.5 $\mu$ s	< $\pm$ 1.5 $\mu$ s	< $\pm$ 1.5 $\mu$ s	< $\pm$ 1.5 $\mu$ s	< $\pm$ 1.5 $\mu$ s
<b>Short term (1min) power stability</b> <sup>(4)</sup>	< $\pm$ 1%	< $\pm$ 1%	< $\pm$ 2%	< $\pm$ 2%	< $\pm$ 2%
<b>Long term (6 hrs) power stability</b> <sup>(4)</sup>	< $\pm$ 3%	< $\pm$ 3%	< $\pm$ 5%	< $\pm$ 5%	< $\pm$ 5%
<b>Spectral properties</b>	Single Longitudinal Mode Linewidth: 0.8pm	Single Longitudinal Mode	Single Longitudinal Mode Linewidth: 0.5pm	Single Longitudinal Mode Linewidth: 0.3pm	Single Longitudinal Mode Linewidth: 0.3pm
<b>Beam profile</b>	Gaussian TEM00	Gaussian TEM00	Gaussian TEM00	Gaussian TEM00	See note (8)
<b>Full angle divergence</b>					
<b>Horizontal@1/e<sup>2</sup></b>	10 $\pm$ 2mrad	10 $\pm$ 2mrad	11 $\pm$ 2mrad	11 $\pm$ 2mrad	11.5 $\pm$ 2mrad
<b>Vertical@1/e<sup>2</sup></b>	9 $\pm$ 2mrad	9 $\pm$ 2mrad	7 $\pm$ 2mrad	7 $\pm$ 2mrad	0.65 $\pm$ 0.25mrad
<b>M<sup>2</sup></b> <sup>(5)</sup>	<1.3	<1.3	<1.3	<1.3	<1.4
<b>Beam ellipticity</b> <sup>(6)</sup>	<1.3	<1.3	<1.3	<1.3	N/A
<b>Main Lobe Gaussian Fit</b> <sup>(7)</sup>	N/A	N/A	N/A	N/A	>85%
<b>Polarization</b>	Linear PER>20dB	Linear PER>20dB	Linear PER>20dB	Linear PER>20dB	Linear PER>20dB
<b>Package dimensions</b>	144x42x36mm	186x60x36mm	186x60x36mm	186x60x36mm	210x60x36mm
<b>Package weight</b>	300g	500g	500g	500g	500g
<b>Options (table p3)</b>	0,1,2,3,4	0,1,2,3,4,C	0,1,2,3,4,C	0,1,2,3,4,C	0,1,2,3,4,C
<b>Options included</b>	S	S	S	S	S

**NOTES**

- (1) See options p3
- (2) Measured with 1GHz photodiode and 1GHz/10GS/s oscilloscope.
- (3) PCD = Pulse Creation Delay, the delay between the trigger command and the effective pulse firing
- (4) For temperature variation <  $\pm$  3°C and < 3°C/hour, stability is measured with calorimeter – detector band [DC, 2Hz]
- (5) Mean average value  $M = \sqrt{XY}$ , X and Y being respectively the major and minor axis of the ellipse
- (6) Beam ellipticity is calculated as the ratio of the main axis far field divergence
- (7) Measurement performed in the far field with a WincamTD-U series camera
- (8) Beam exhibits different profile in horizontal (Gaussian) and vertical ((sin x /x)<sup>2</sup> in far-field) plans
- (9) Contact factory for availability

## COMPLEMENTARY INFORMATION & OPTIONS

Environment Parameters	
Operating Temperature Range	0-50°C for STG 15-35°C for STV and STU
Maximum Laser Head Baseplate Temperature	50°C for STG 40°C for STV and STU
Maximum Power Consumption	<40W
Laser Head Thermal Dissipation	<15W
Storage Temperature	0-50°C
Shock of 11ms according to IEC 68-2-27, non operating	25g
Vibration 5Hz to 500Hz sinusoidal according to IEC 68-2-6	2g

Certification	
Laser classification according to IEC 60825-1:2007	3B Except STU-01E : 4
CDRH	Yes, if used with a MLC-03A-DP1 controller
ROHs	Yes

Options	
Fixed Repetition Rate = $RR_{max}$	-10x version
Fixed Repetition Rate $\neq RR_{max}$	-11x version ; RR to be chosen over 10Hz- $RR_{max}$
External Variable Repetition Rate	-12x version ; single shot to $RR_{max}$ , 1 optimized RR value
External Variable Multi-Repetition Rate	-13x version ; single shot to $RR_{max}$ , 3 optimized RR values
External Continuous Variable Repetition Rate	-14x version ; optimized over [10Hz- $RR_{max}$ ] if $RR_{max} \leq 2kHz$ ; or [10Hz - 2kHz] if $RR_{max} > 2kHz$
Multimode fibering (M)	Contact factory for availability
Single mode fibering (F)	Contact factory for availability
Collimation (C)	Contact factory for availability
Synchronization output (S)	TTL compatible output signal for synchronization/monitoring

Available Controller Types			
Model	Type	Input Power	CDRH
MLC-03A-DP1	Desktop	100-240 V AC	Yes
MLC-03A-MP1	Module	12 V DC	No
MLC-03A-BP1	Board	12 V DC	No

# CDRH LASER HEAD MECHANICAL DRAWINGS: STG-03E-1X0, STG-05E-1X0

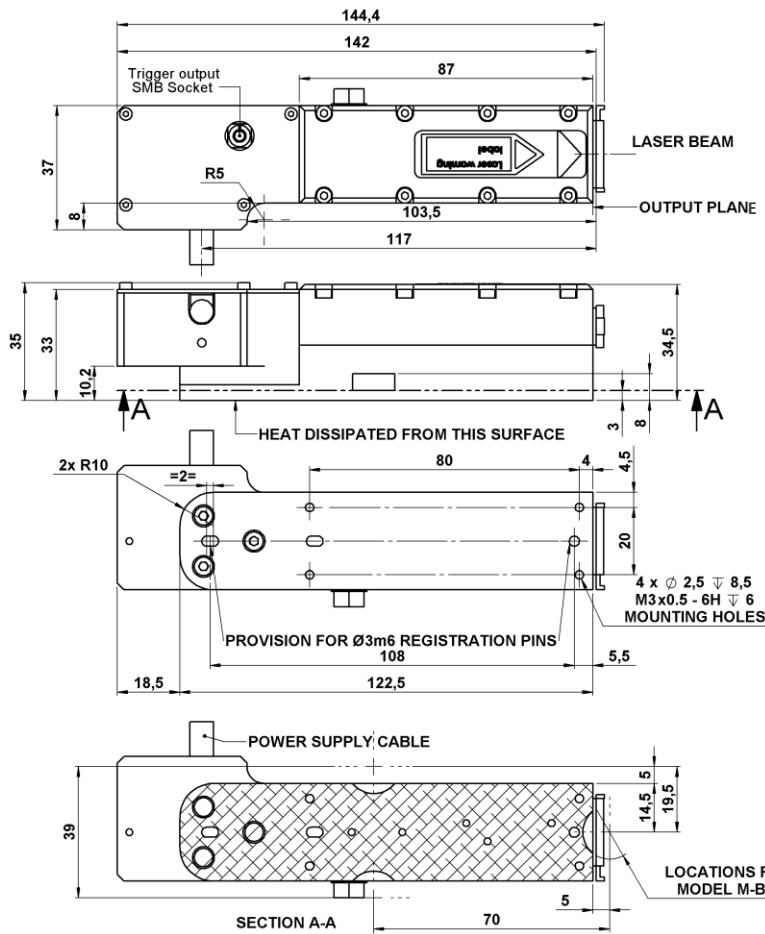

NOTES: All dimensions are in millimeters  
Third Angle Projection

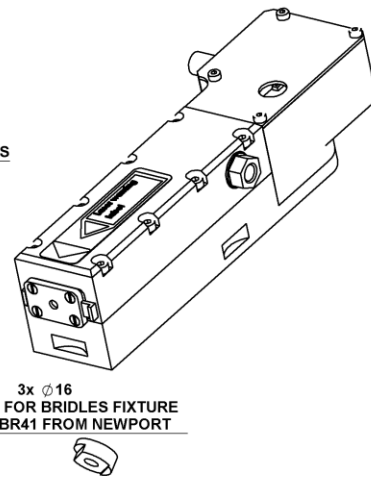
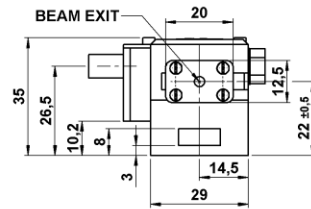

# CDRH LASER HEAD MECHANICAL DRAWINGS: STV-01E-1X0, STV-02E-1X0

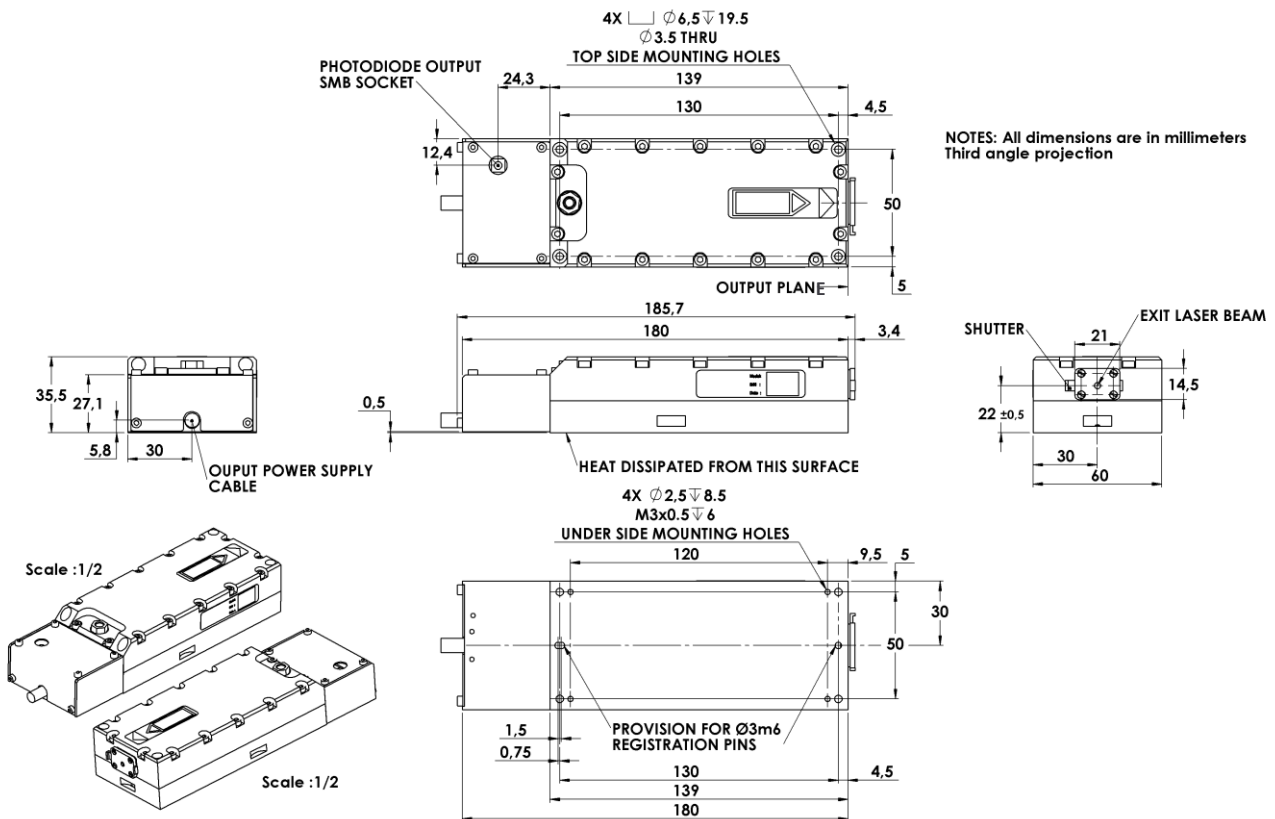

# CDRH LASER HEAD MECHANICAL DRAWING: STU-01E-1X0

