

DATASHEET AND OPERATING GUIDE

PLD10000/PLD12500

Laser Diode Drivers

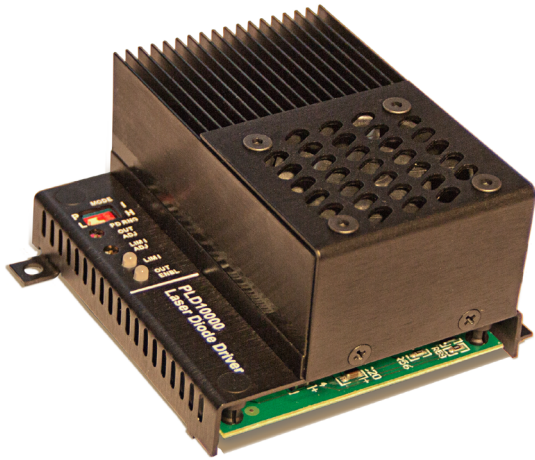

FEATURES AND BENEFITS

- Two models: 10 A and 12.5 A output current
- PLD10000 can be operated from a 5 VDC supply
- Separate power supply can be used to drive high-compliance lasers, up to 27.5 V
- Constant Current or Constant Power modes
- Safety features protect your laser
 - » Adjustable latching current limit
 - » Slow-start circuitry
- Remote Enable controls
- Optimized heatsink and fan simplifies integration

RELIABILITY YOU CAN TRUST

The PLD Series Laser Diode Drivers deliver the reliability and performance you expect from a Wavelength Electronics laser driver in a compact and easy-to-integrate package. Tens of thousands of PLD drivers are deployed in laser systems around the world, proving beyond doubt the reliability and stability of the design.

PLD Series drivers are used for fiber laser pumping, materials processing, pyrotechnic ignition, industrial applications, and laser diode LIV testers.

DESIGNED FOR EASY INTEGRATION

The PLD10000 is powered by a 5 V supply, and the laser can be driven from the same supply. High-compliance lasers can be driven by using a separate supply up to 30 V. The PLD12500 requires two separate supplies.

LASER SAFETY FEATURES

Built-in safety features make your product more robust to real world operating conditions: latching current limit switches off the output if the current limit is reached; a slow start circuit ramps the output current; and a mechanical shorting relay protects the laser from ESD events while the output is switched off.

Long-term reliability means better up-time, fewer service calls, and more customers who are satisfied with your products.

LOWER CURRENT MODELS

The PLD Series is available in lower current models. Go to our website for information on the PLD200, PLD500, PLD1250, PLD5000, and PLD6500 Laser Diode Drivers.

CONTENTS

	PAGE
QUICK CONNECT GUIDE	2
PIN DESCRIPTIONS	4
ELECTRICAL SPECIFICATIONS	5
SAFETY INFORMATION	6
OPERATING INSTRUCTIONS	7
ADDITIONAL TECHNICAL INFORMATION	13
TROUBLESHOOTING	18
MECHANICAL SPECIFICATIONS	19
CERTIFICATION AND WARRANTY	20

ORDERING INFORMATION

PART NO	DESCRIPTION
PLD10000	10 A Laser Diode Driver
PLD12500	12.5 A Laser Diode Driver
PLD10EV	Evaluation board for PLD10000 and PLD12500
USBKIT	USB Interface kit, with software

QUICK CONNECT GUIDE



TO ENSURE SAFE OPERATION OF THE PLD DRIVER, IT IS IMPERATIVE THAT YOU DETERMINE THAT THE UNIT WILL BE OPERATING WITHIN THE INTERNAL HEAT DISSIPATION SAFE OPERATING AREA (SOA).

Visit the Wavelength Electronics website for the most accurate, up-to-date, and easy to use SOA calculator:

<https://www.teamwavelength.com/support/design-tools/soa-ld-calculator/>

Figure 1 shows the top view of the PLD driver and the locations of the configuration switches, Output and Current Limit adjust trimpots, and status LEDs.

Figure 2 shows a typical wiring diagram for the PLD driver and external electronics to operate a Type A or B laser.

Figure 3 illustrates the three laser types that the PLD can drive. For detailed instructions on using the different laser types refer to the **Operating Instructions on page 7**.

* DO NOT change switch positions while the output is enabled; Doing so may damage the laser diode.

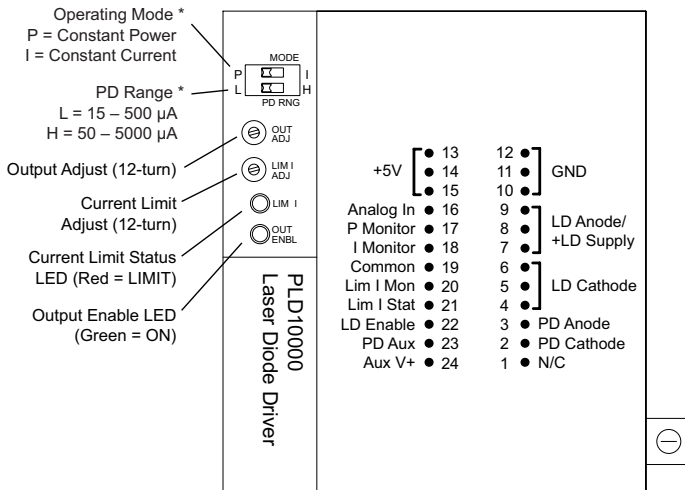

Figure 1. PLD Top View and Pin Layout

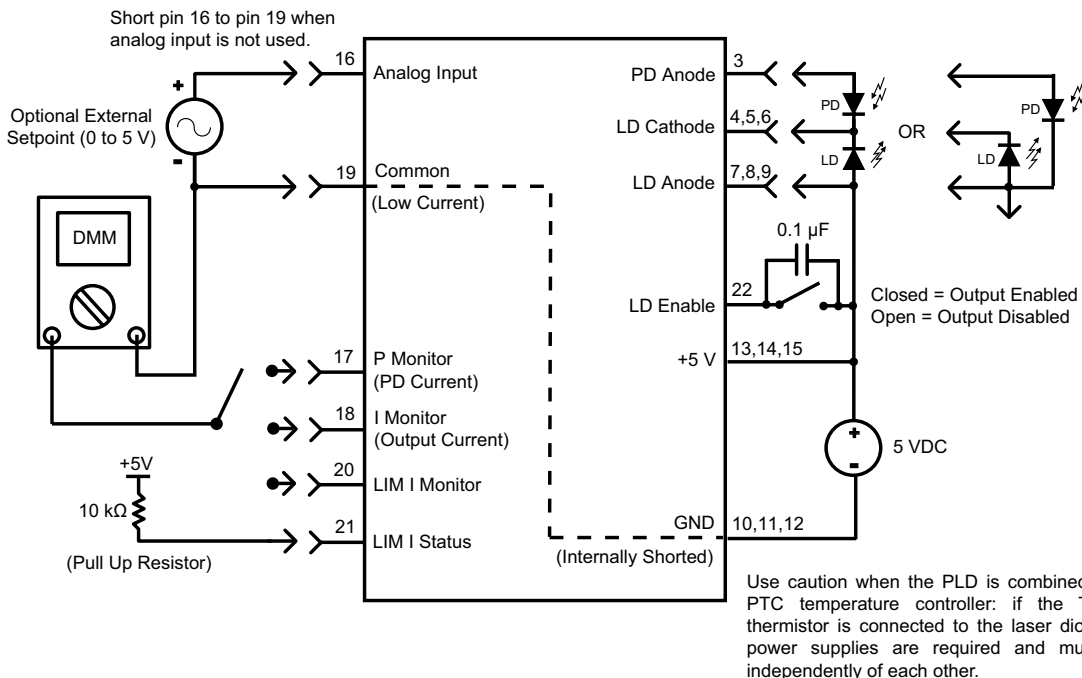

Figure 2. PLD10000 / PLD12500 Wiring Diagram, Type A/B Lasers

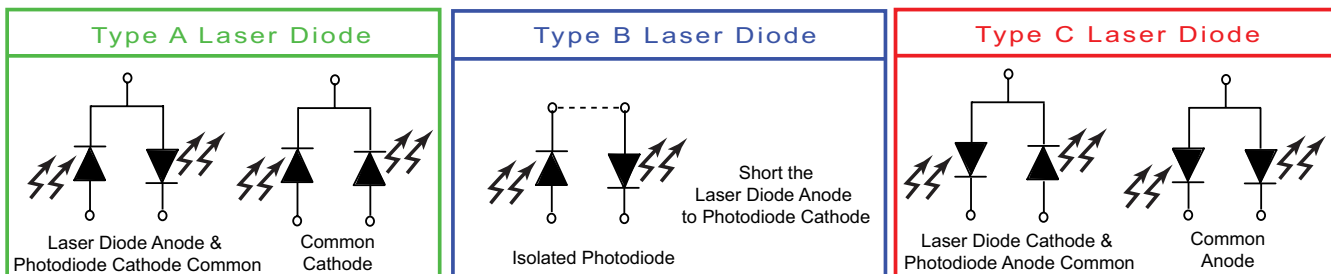

Figure 3. Laser Type Diagrams

QUICK CONNECT GUIDE, CONTINUED

We recommend using a test load to configure the PLD; refer to **Figure 4**. When using the test load, the actual drive current can be determined by measuring the voltage drop across the resistor. Do not place an ammeter in series with the load circuit.

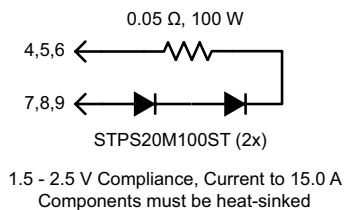

Figure 4. Laser Test Load, Constant Current Mode

PIN DESCRIPTIONS

Table 1. Pin Descriptions

PIN	NAME	PIN DESCRIPTION
1	No Connect	
2	PD Cathode	Photodiode cathode connection for Type C lasers only; see Figure 9 on page 10 .
3	PD Anode	Photodiode anode connection for Type A & B lasers. Photodiode feedback is required for Constant Power-mode operation. Tie this pin to PD Aux (pin 23) for Type C lasers (see page 10).
4, 5, 6	LD Cathode	Laser diode cathode connection.
7, 8, 9	LD Anode / +LD Supply	Laser diode anode connection. Also used as power supply input for high-compliance lasers. Maximum input voltage 30 VDC. On PLD12500, the supply voltage (+5 V) and LD Anode must be separate supplies.
10, 11, 12	GND	Power supply ground. Used with +5 V for high current return.
13, 14, 15	+5 V	Supply voltage to control electronics. Range 4.5 to 5.5 VDC. The power supply must be rated to source at least 1.1-times the laser current plus the PLD quiescent current. On PLD12500, the supply voltage (+5 V) and LD Anode voltage must be separate supplies.
16	Analog Input	Remote setpoint or modulation input. Transfer function varies by model and operating mode—refer to Table 2 . Range 0 to 5 V. Impedance 1 MΩ. Not TTL-compatible. Connect Analog Input pin to Common (pin 19) when not using the Analog Input function. The Analog Input signal sums with the onboard setpoint value. See Electrical Specifications for damage threshold information.
17	P Monitor	Photodiode Current Monitor (power monitor). Transfer function varies by PD feedback range setting—refer to Table 2 . Range 0 to 2.5 V. Impedance 1 kΩ.
18	I Monitor	Laser Diode Output Current Monitor. Transfer function varies by model—refer to Table 2 . Range 0 to 2.5 V. Impedance 1 kΩ.
19	Common	Measurement ground. Low current return used only with Monitor pins and Analog Input. Internally shorted to GND (pins 10, 11, 12).
20	LIM I Monitor	Current Limit Monitor. Transfer function varies by model—refer to Table 2 . Range 0 to 2.5 V. Impedance 1 kΩ. The current limit voltage should be set 0.2 V above the desired limit level. Instructions for fine-tuning the current limit are on page 13 .
21	LIM I Status	Status output pin. Indicates if the driver has reached current limit and has switched off the output. Signal is < 0.3 V if the driver is in limit and output is latched off; signal is at 5 V when output is not in limit. Toggle LD Enable to reset the limit circuit and enable the output current.
22	LD Enable	Output Enable. Disable = ground or floating. Enable = 3 to 5 V. Requires 5 mA input current. Not TTL-compatible.
23	PD Aux	For TYPE C Laser Diodes only. See Figure 9 on page 10 .
24	Aux V+	For TYPE C Laser Diodes only. See Figure 9 .

Table 2. Current Output Monitor, Limit Monitor, Photodiode Current Monitor, and Analog Input Transfer Functions

FUNCTION	MODE	PLD10000	PLD12500
LIM I Monitor (Current Limit)	CC / CP	4.6 A / V	5.0 A / V
I Monitor (Output Current)	CC / CP	4.6 A / V	5.0 A / V
Analog Input; CC-Mode	CC	2.3 A / V	2.5 A / V
Analog Input CP-Mode; Low Range	CP	100 μA / V	
Analog Input, CP-Mode; High Range <small>See Note</small>	CP	1 mA / V	
P Monitor (Photodiode Current); Low Range	CC / CP	200 μA / V	
P Monitor (Photodiode Current); High Range <small>See Note</small>	CC / CP	2 mA / V	

Note: High Range is not available when using Type C Lasers.

ELECTRICAL SPECIFICATIONS

PARAMETER	SYMBOL	MIN	TYP	MAX	UNIT	NOTE
ABSOLUTE MAXIMUM RATINGS						
Supply Voltage ¹	+5 V	5.0 to 5.5			VDC	
Supply Voltage, LDA High Compliance ^{1,2}	LD Anode / +LD Supply	3.0 to 30			VDC	Consult Safe Operating Area calculator for supply voltages > 5 VDC
Supply Voltage, Type C Lasers	Aux V+	8.0 to 12.5			VDC	
Operating Temperature Range ³	T _{OPR}	0 to 50			°C	
Storage Temperature Range	T _{STG}	-55 to 125			°C	
Weight		8.4			oz	235 grams
Size		3.35 x 3.20 x 1.93			in	85.1 x 81.3 x 49.0 mm

PARAMETER	MODEL		UNIT
	PLD10000	PLD12500	

DRIVE CURRENT OUTPUT			
Maximum Internal Power Dissipation	110	110	W
Maximum Output Current	10	12.5	A
Compliance Voltage	2.5 V max with 5 VDC power supply voltage 27.5 V max with 30 VDC power supply voltage		V
Short Term Stability, 1 hour, Constant Current Mode	< 200	< 300	ppm
Quiescent Current	250	250	mA
Temperature Coefficient	< 200		ppm

PHOTODIODE FEEDBACK			
High Range Photodiode Input Current	50 – 5000		µA
Low Range, Type A & B Lasers Only	15 – 500		µA
Short Term Stability, 1 hour, Constant Power Mode	< 0.05	< 0.05	%

EXTERNAL MODULATION			
Analog Input Damage Threshold	V _{IN} < -0.5 or V _{IN} > (0.5 V above Supply Voltage on Pin 15)		V
Input Pin Impedance	1		MΩ
Bandwidth, 3 dB ⁴	90	70	kHz
Depth of Modulation at 60 kHz ⁵	90		%
Rise Time	7	7	µsec
Fall Time	8	8	µsec

TIMING CHARACTERISTICS^{6,7}			
Output Turn-on Delay	≥1.5		seconds
Slowstart Output On-Time	250		msec
Disable Fall Time	>100		µsec

MONITOR ACCURACY			
Monitor Voltage vs. Expected Output based on transfer function	2		% of Full Scale

- Single 5 VDC supply operation is possible with PLD10000. Two supplies are required for PLD12500.
- Use two supplies with PLD10000 when driving high-compliance lasers, or when lower drive current noise is required. PLD12500 requires two supplies.
- PLD12500 maximum operating temperature is 35°C.
- Modulation bandwidth in Constant Power mode will depend on the photodiode frequency response. Photodiode specifications vary widely from one manufacturer to another, but the bandwidth in Constant Power mode is typically 10% of the Constant Current bandwidth.
- Peak-to-Peak output amplitude decreases as frequency increases. See figure at right.
- See **page 16** for timing graphs.
- See **page 15** for revision A & B timing characteristics.

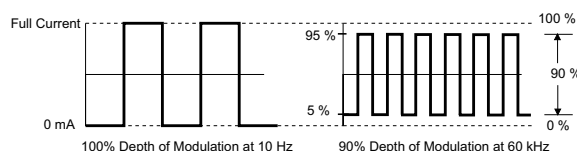

SAFETY INFORMATION

SAFE OPERATING AREA – DO NOT EXCEED INTERNAL POWER DISSIPATION LIMITS

Before attempting to operate the PLD driver, it is imperative that you first determine that the unit will operate within the *Safe Operating Area* (SOA). Operating outside of the SOA may damage the PLD and the laser. Operating outside of the SOA will void the warranty.

To determine if the PLD driver is suitable for your application and if it will be operating in the safe range, consult the online instructions for calculating the Safe Operating Area:

<https://www.teamwavelength.com/support/design-tools/soa-ld-calculator/>

SOA charts are included in this datasheet for quick reference (**page 17**), but we recommend you use the online tools instead.



TO ENSURE SAFE OPERATION OF THE PLD DRIVER, IT IS IMPERATIVE THAT YOU DETERMINE IF THE UNIT IS GOING TO BE OPERATING WITHIN THE INTERNAL HEAT DISSIPATION SAFE OPERATING AREA (SOA).

If you have any questions about the Safe Operating Area calculator call the factory for free and prompt technical assistance.

THEORY OF OPERATION

The PLD10000 and PLD12500 drivers are controlled linear-mode current sources: they deliver the current commanded by the setpoint. The current source continually monitors the actual output current, compares it to the setpoint, and adjusts the current if there is a difference between the two signals.

It may be useful to remember that you do not directly set the drive current setpoint; instead, you adjust a voltage signal that represents the output current. The voltage and output current are related by a transfer function that varies by driver model number.

The setpoint voltage is adjusted with the onboard trimpot or by an external input that sums with the onboard setpoint. The adjustable current limit is set using an onboard trimpot.

As current is driven through the load, there is a voltage drop across the load because of the impedance. As the current increases, the voltage drop may increase to the point that it reaches the Compliance Voltage limit of the current source. Once that occurs the current source is no longer able to increase the current driven to the load even if you increase the setpoint.

The PLD driver includes features that help protect your laser and make the driver more versatile in a wide array of applications:

- The user-adjustable latching current limit protects the laser from over-current situations by switching off the output when a limit condition is detected. Toggling the Enable resets the current limit circuit.
- Output current switches on after approximately 1.5 seconds from the time the Enable signal is applied.
- Output slow-start ramps the current to setpoint over 250 msec.

OPERATING INSTRUCTIONS

If you are using the driver on the benchtop or for prototyping your laser control system, we recommend using the PLD10EV board.

The driver is first configured for local control in order to set the drive current limit. Then the driver is reconfigured according to the actual application.

We recommend using a test load until you are familiar with operation of the driver. Refer to **page 3** for test load schematics.

NECESSARY EQUIPMENT

The following equipment is the minimum necessary to configure the PLD for basic operation:

- PLD controller
- PLD10EV evaluation board (recommended)
- Digital multimeter, 4-½ digit resolution recommended
- Test load for configuring the driver; laser diode, mount, and laser temperature controller
- Connecting wires
- Power Supplies (see below)

POWER SUPPLY REQUIREMENTS

Linear-regulated or low-noise switching power supplies can be used. We recommend using power supplies with noise specifications suitable for your application.

For single-supply operation (PLD10000 only):

- 5 VDC power supply rated for 1.1-times the maximum laser diode current, plus 250 mA for the electronics

For the PLD12500, or to drive a high-compliance laser with the PLD10000:

- 5 VDC power supply rated for > 250 mA
- Power supply rated for 1.1-times the maximum laser diode drive current and > 2.5 V greater than the compliance voltage of the laser

SAFE OPERATING AREA AND THERMAL DESIGN CONSIDERATIONS

SOA charts are included in this datasheet for quick reference, but we recommend you use the online tools instead:

<https://www.teamwavelength.com/support/design-tools/soa-ld-calculator/>



IT IS IMPERATIVE THAT YOU VERIFY THE UNIT WILL OPERATE WITHIN THE INTERNAL HEAT DISSIPATION SAFE OPERATING AREA (SOA).

OPERATING THE DRIVER OUTSIDE THE SOA MAY DAMAGE OR DESTROY THE DRIVER AND/OR LASER.

PREVENT DAMAGE FROM ELECTROSTATIC DISCHARGE

Before proceeding, it is critical that you take precautions to prevent electrostatic discharge (ESD) damage to the driver and your laser. ESD damage can result from improper handling of sensitive electronics, and is easily preventable with simple precautions.

Enter the search phrase ESD Precautions for Handling Electronics in an internet search engine to find information on ESD-safe handling practices.

We recommend that you always observe ESD precautions when handling the PLD driver and your laser diode.

INSTALL THE PLD ON THE PLD10EV BOARD

Align the pins of the PLD with the plated holes on the evaluation board, making sure all pins are aligned before seating the PLD on the board.



VERIFY THAT THE PLD IS PROPERLY ORIENTED ON THE BOARD, WITH PIN 1 AT THE CORRECT LOCATION. REFER TO FIGURE 5.

Next, insert the two 4-40 x 1/4" screws through the tabs on the PLD and into the threaded inserts on the PCB; then tighten. Finally, solder the PLD pins to the PLD10EV board.

It is essential to mechanically secure the PLD to the circuit board with the 4-40 x 1/4" screws. The electrical pins alone do not provide sufficient mechanical strength to secure the PLD to the circuit board.

CONFIGURE THE PLD10EV BOARD FOR YOUR APPLICATION

If you are using the PLD10EV evaluation board to familiarize yourself with operating the PLD10000 or PLD12500, follow these instructions to configure the jumpers on the evaluation board. Refer to Figure 5.

- **Laser Type-Select Jumper.** Remove this jumper for Type A/B laser operation. Install the jumper to tie pin 3 to pin 23 for Type C laser operation. The factory default configuration is with the jumper removed.
- **LD Power Supply Jumper.** To operate the PLD and laser from a single 5 VDC power supply, install this jumper. If you are operating a high-compliance laser with a separate power supply, remove the jumper. The jumper must be removed when using the PLD12500. The factory default configuration is with the jumper installed.

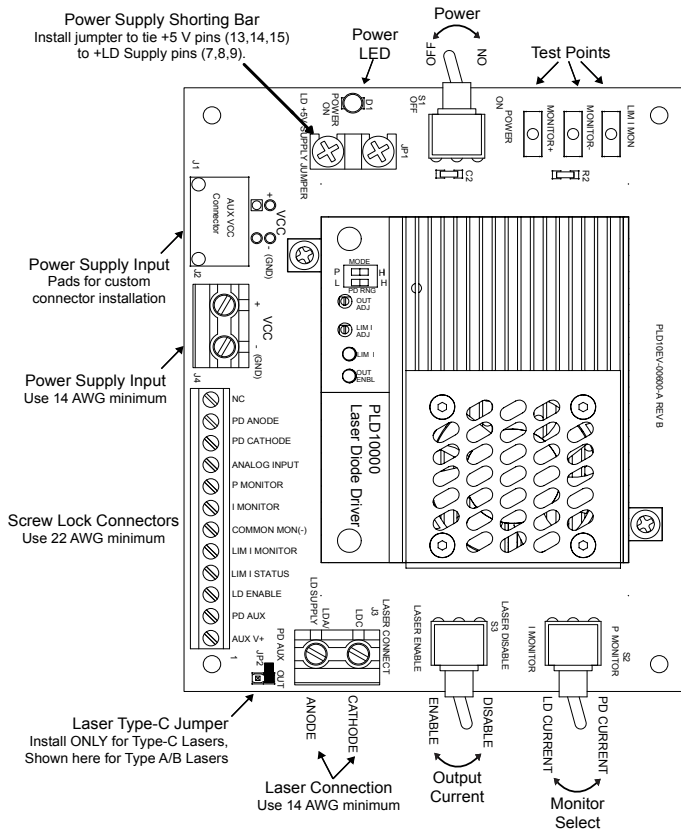

Figure 5. PLD10EV Evaluation Board

WIRE THE PLD LASER DRIVER

Refer to Table 3 for wiring instructions specific to your configuration. For setup and configuration use a test load. The same wiring instructions apply whether the PLD is used on the PLD10EV board or installed on a custom circuit board.

Table 3. Wiring Configurations

CONFIGURATION	DIAGRAM
Type A & B Laser Diode, Single 5 VDC Power Supply	Figure 6
Type A & B Laser Diode, High-Compliance Laser Diode	Figure 7
Type A & B Laser Diode, Negative Supply Operation	Figure 8
Type C Laser Diode, Single Power Supply	Figure 9

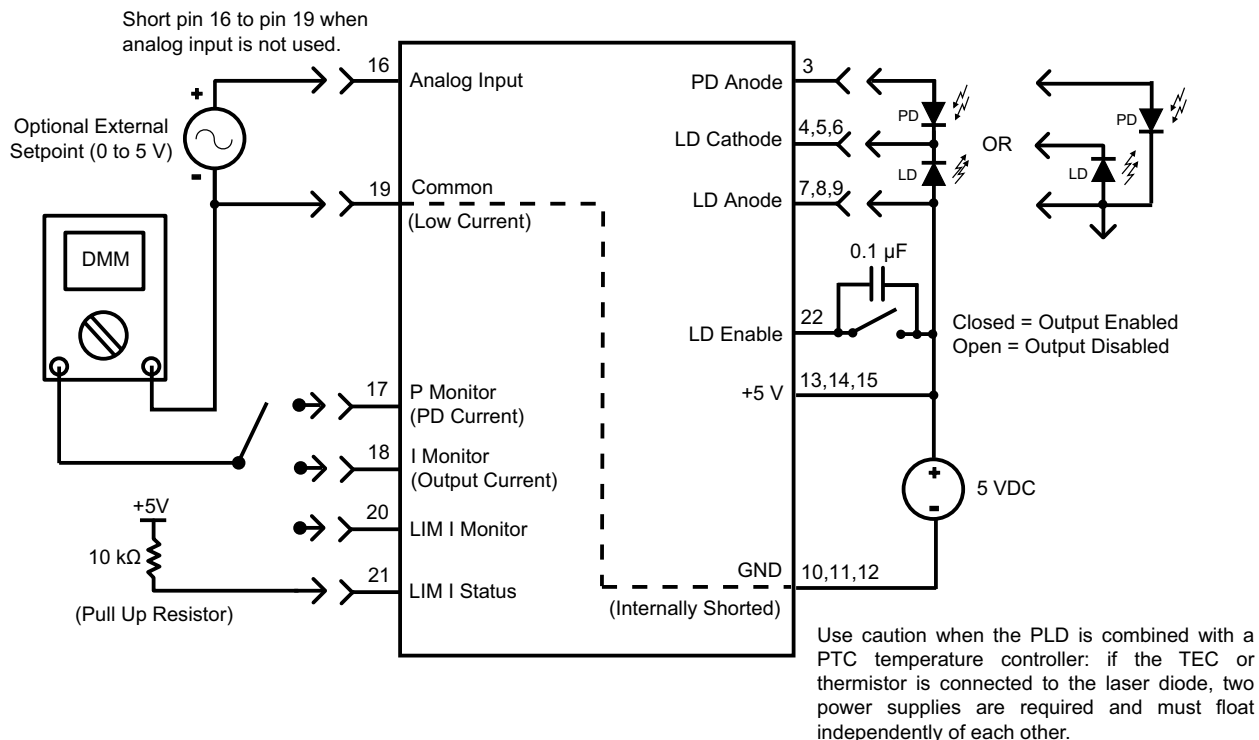

Figure 6. Type A & B Laser Diode, Single 5 VDC Power Supply

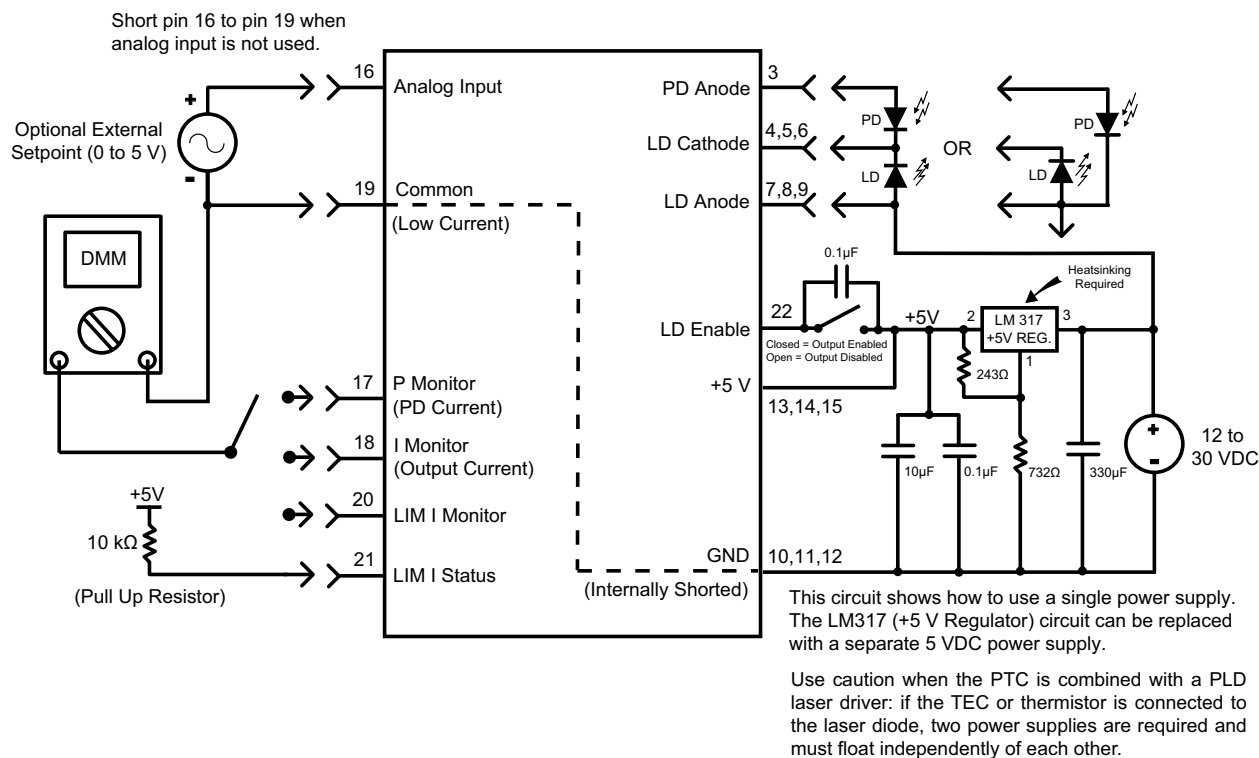

Figure 7. Type A & B Laser Diode, High-Compliance Laser Diode

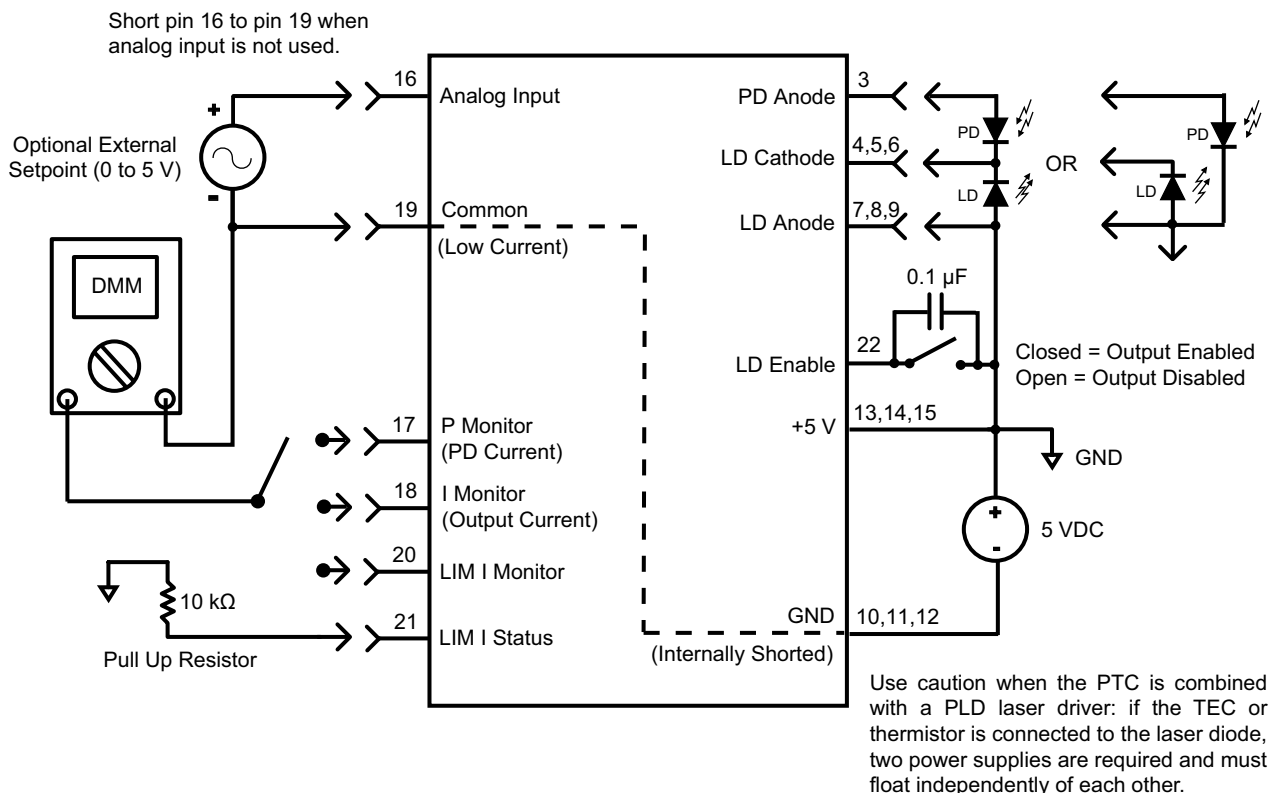

Figure 8. Type A & B Laser Diode, Negative Power Supply Operation

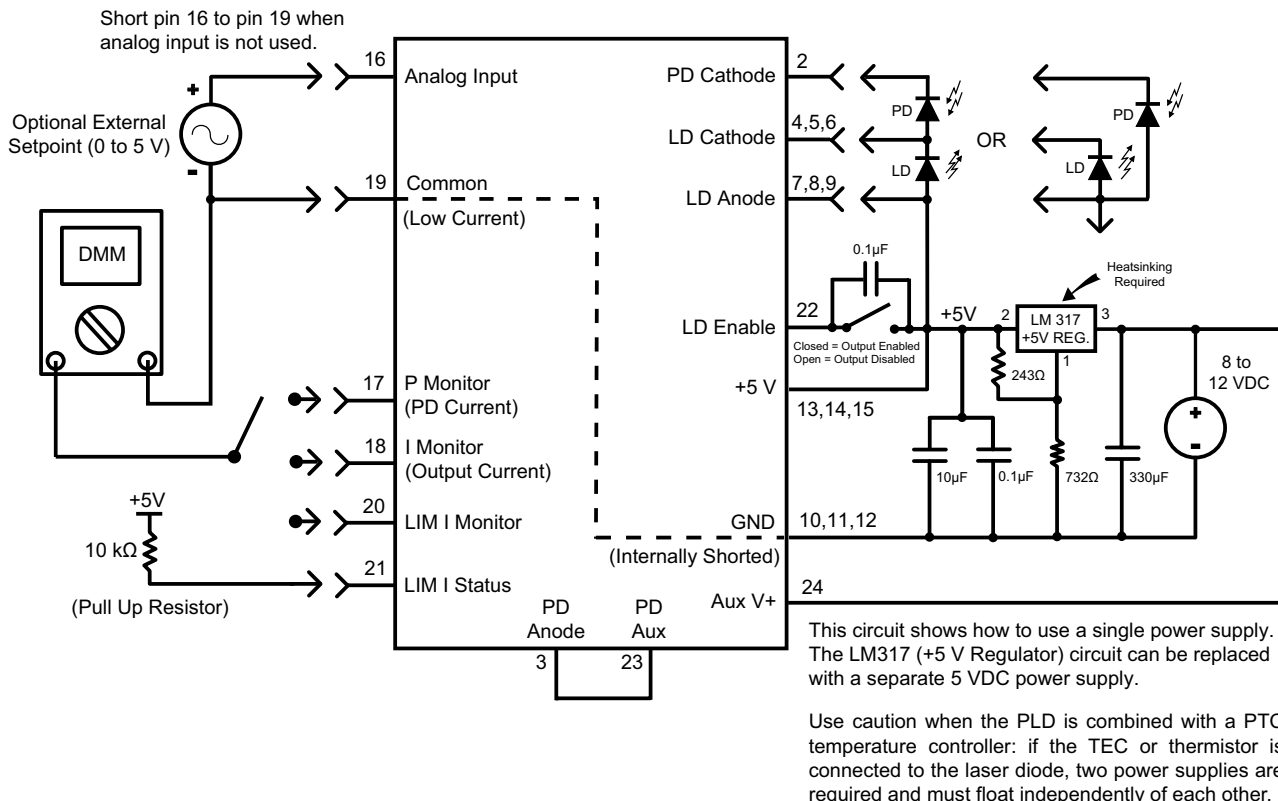

Figure 9. Type C Laser Diode

ONBOARD ADJUSTMENTS AND CONTROLS

Onboard controls are on the top of the PLD and must be set according to the operation mode. The controls are illustrated in **Figure 10**.

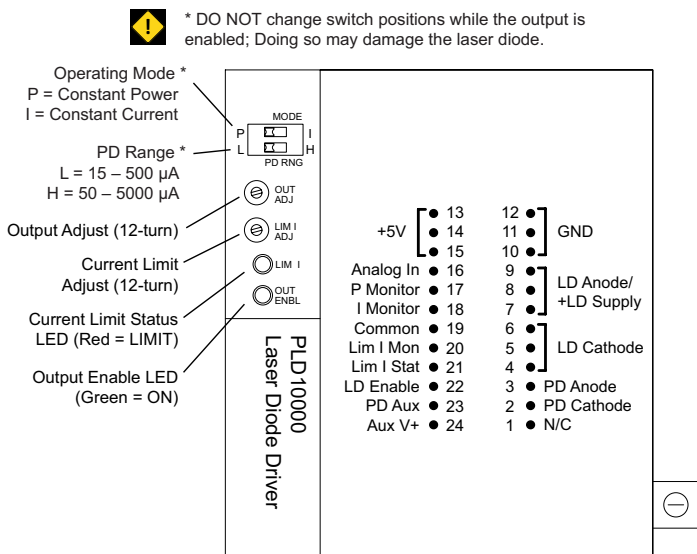

Figure 10. PLD Driver Adjustments and Controls

SET THE CONTROL MODE

Set the MODE switch to P (left) for Constant Power-mode operation (CP), or to I (right) for Constant Current-mode operation (CC). CP-mode operation requires a photodiode feedback loop from the laser diode.



DO NOT SWITCH THE CONTROL MODE WHILE THE OUTPUT IS ENABLED AND DRIVING A LASER DIODE. THE LASER DIODE MAY BE DAMAGED OR DESTROYED.

SET THE PHOTODIODE RANGE

Two photodiode feedback current ranges are available on the PLD drivers. Reference the datasheet for your laser diode to find the nominal photodiode current, and set the PD RANGE switch as follows:

- L (left) = Low Range, PD current 15 – 500 µA, Type A and B lasers only
- H (right) = High range; PD current 50 – 5000 µA



DO NOT SWITCH THE PD RANGE WHILE THE OUTPUT IS ENABLED AND DRIVING A LASER DIODE. THE LASER DIODE MAY BE DAMAGED OR DESTROYED.

CALCULATE THE MONITOR VOLTAGES

Refer to the datasheet for your laser to determine the maximum forward current, and calculate the LIM I Monitor voltage using this equation and the transfer function found in **Table 2**:

$$V_{\text{Lim I Mon}} = I_{\text{LIMIT}} / \text{Transfer Function}$$

If you are using the PLD in Constant Current mode, calculate the monitor voltage for the drive current setpoint. Refer to the datasheet for your laser to determine the nominal forward current, and calculate the I Monitor voltage using the transfer function found in **Table 2**:

$$V_{\text{I_MON}} = I_{\text{LD}} / \text{Transfer Function}$$

If you are using the PLD in Constant Power mode, calculate the P Monitor voltage. Refer to the laser diode datasheet to determine the nominal photodiode current at the desired operating point. Calculate the P Monitor voltage using the transfer function found in **Table 2**:

$$V_{\text{P_MON}} = I_{\text{PD}} / \text{Transfer Function}$$

SET THE CURRENT LIMIT

Connect the positive lead of the digital voltmeter to the LIM I Mon pin, or to the LIM I MON test point on the evaluation board. Connect the negative lead to the COMMON terminal.

Reference **Figure 5** for switch and control locations on the PLD and PLD10EV board, and configure the PLD and evaluation board:

- Set the POWER switch to ON
- Set the OUTPUT switch to LASER DISABLE
- Set the MONITOR switch to I MONITOR
- Set the OUTPUT ADJUST trimpot to zero by turning at least 12 turns counter-clockwise.
- Turn the CURRENT LIMIT ADJUST trimpot clockwise until the value on the digital multimeter matches the $V_{\text{Lim I Mon}}$ value calculated above.

Switch off power on the evaluation board, then switch off the power supply.

The PLD controllers trip the current limit circuit below the expected limit level, by 0.2 V on the monitor. To trip the current limit at exactly the desired current level, refer to **Set the Current Limit More Accurately on page 13**.

ADJUST THE OUTPUT CURRENT SETPOINT— ONBOARD CONTROL

To increase the output current, turn the onboard trimpot clockwise; turn counter-clockwise to decrease output current.

While adjusting the output current, measure the voltage on pin 18, I Monitor. Use the transfer function listed in **Table 2** to determine the output current from the monitor voltage.

ADJUST THE OUTPUT CURRENT SETPOINT— ANALOG INPUT

To use the Analog Input pin to adjust the output current, refer to **Pin Descriptions on page 4** for specifications. The analog input signal sums with the onboard trimpot value.

Refer to the **External Setpoint Circuit on page 14** for an example analog input circuit. Other circuits, a DAC signal, or function generator may be used.

COMBINING THE ONBOARD SETPOINT AND ANALOG INPUT

The Analog Input voltage signal on pin 16 sums with the onboard trimpot setpoint. This configuration allows the driver to be configured so that the laser current or power modulates around a DC setpoint.

If the sum of the two signals causes the PLD to attempt to drive the output current past the limit, the output will switch off and indicate a current limit error.

To avoid driving the current to the limit, first set the onboard trimpot to produce the constant current level. Then connect the modulation source to the Analog Input pin and slowly increase the modulation amplitude. Monitor the output current using the I Monitor pin, or by measuring the voltage across the test load. Do not monitor the voltage across a laser diode—measurement transients may damage the laser diode.

CURRENT LIMIT CIRCUIT TRIGGER AND RESET

If the PLD detects current limit, the output will switch off and the LIMIT I LED on the top of the unit will illuminate red. Set the Enable switch to OFF, correct the cause of the error, and then re-enable the output.

ADDITIONAL TECHNICAL INFORMATION

This section includes useful technical information on these topics:

- Remote Limit Status LED Circuit
- Set the Current Limit More Accurately
- Change the Photodiode Range, Type A & B Lasers
- Change the Photodiode Range, Type C Lasers
- Change the Analog Input Modulation Transfer Function
- External Setpoint Circuit
- Important Information on Grounding
- Fine Tune Deep Modulation
- Cable Lengths and High Current
- Add Laser Diode Protection for Long Cables
- Additional Noise Filtering
- Revision A & B Timing Characteristics
- Monitor Calibration Circuit
- Product Variations
- Output On/Off and Current Limit Timing

REMOTE LIMIT STATUS LED CIRCUIT

The LIM I Status feature can be used to drive a remote LED in your control system. Connect the LED as shown in **Figure 11**.

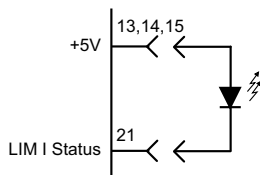

Figure 11. Remote LIM I Status LED

SET THE CURRENT LIMIT MORE ACCURATELY

The current limit circuit is designed with a small hysteresis, which causes the limit circuit to trip at a slightly lower current than calculated. To fine-tune the current limit, a small offset voltage must be factored in. Use this equation to calculate the hysteresis offset, where V_{+5V} is the supply voltage:

$$\text{Offset (V)} = (V_{+5V} - V_{L_MON}) / 25.9$$

Then add the Offset to $V_{Lim\ I\ Mon}$ calculated on **page 11**.

CHANGE THE PHOTODIODE RANGE, TYPE A & B LASERS

The photodiode current range and transfer function can be adjusted using an external resistor. This feature is useful when the photodiode current of your laser falls in a range that does not allow maximum measurement sensitivity on the PLD driver.

Figure 12 shows the internal resistor network of the PLD photodiode feedback range control; the equations explain the interaction with the external resistor.

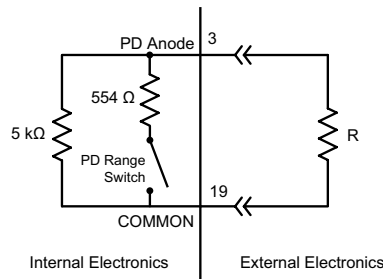

PD Range = L	PD Range = H
$\text{Range} = \frac{2.5\text{ V} * 10^6}{R \parallel 5\text{ k}\Omega} \text{ } [\mu\text{A}]$	$\text{Range} = \frac{2.5\text{ V} * 10^6}{R \parallel 500\ \Omega} \text{ } [\mu\text{A}]$
$\text{Transfer Function} = \frac{10^6}{R \parallel 5\text{ k}\Omega} \text{ } [\mu\text{A} / \text{V}]$	$\text{Transfer Function} = \frac{10^6}{R \parallel 500\ \Omega} \text{ } [\mu\text{A} / \text{V}]$
$R \parallel 5\text{ k}\Omega = \frac{R * 5000}{R + 5000} \text{ } [\Omega]$	$R \parallel 500\ \Omega = \frac{R * 500}{R + 500} \text{ } [\Omega]$

Figure 12. Adjusting the PD Range, Type A & B Lasers

CHANGE THE PHOTODIODE RANGE, TYPE C LASERS

The photodiode range and transfer function can be adjusted when using Type C lasers by connecting a ¼ W resistor between the PD Cathode (pin 2) and AUX V+ (pin 24).

The PD current range is calculated (units are amps):

$$\text{Range} = 2.5\text{ V} / (R \parallel 5\text{ k}\Omega)$$

The transfer function is calculated (units are A / V):

$$\text{Transfer Function} = 1 / (R \parallel 5\text{ k}\Omega)$$

($R \parallel 5\text{ k}\Omega$) is calculated (units are Ω):

$$(R * 5000) / (R + 5000)$$

CHANGE THE ANALOG INPUT MODULATION TRANSFER FUNCTION

The Analog Input Modulation transfer function can be changed by adding a voltage divider resistor network external to the PLD driver. **Figure 13** illustrates a simple circuit.

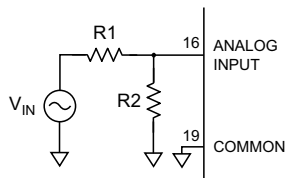

$$\text{New Transfer Function} = \frac{R2}{R2 + R1} * \text{Built-In Transfer Function}$$

Example: R1 = 9 kΩ
(for PLD10000) R2 = 1 kΩ

$$\text{New Transfer Function} = \frac{1}{1 + 9} * 2.3 \text{ A/V} = 0.23 \text{ A/V}$$

Keep R1 and R2 below 100 kΩ for maximum accuracy.

Figure 13. Changing the Analog Input Modulation Transfer Function

EXTERNAL SETPOINT CIRCUIT

An external trimpot circuit can be used to adjust the laser current setpoint; refer to **Figure 14**.

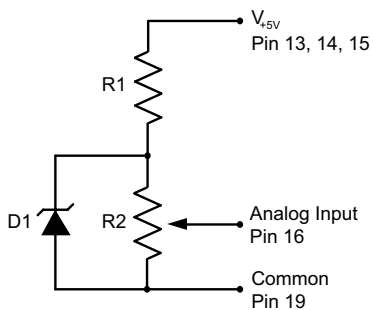

V_{5V} = Supply voltage
D1 = Bandgap reference* (LM4040)
R1 = 2.2 kΩ, 1 W resistor
R2 = Trimpot, 10 kΩ to 100 kΩ

*V_{5V} must be at least 1 volt greater than the voltage value of D1.

Figure 14. Trimpot Circuit for Analog Input

IMPORTANT INFORMATION ON GROUNDING

Some laser diodes connect the laser anode or cathode to the case. Pay particular attention to grounding to ensure safe operation of the PLD and laser.



IT IS CRITICAL THAT THE PLD DRIVER IS PROPERLY GROUNDED. IF THE PLD DRIVER IS USED WITH A WAVELENGTH ELECTRONICS TEMPERATURE CONTROLLER, YOU MAY NEED TO USE TWO SEPARATE POWER SUPPLIES THAT FLOAT INDEPENDENTLY OF EACH OTHER.

If the laser anode is connected to the laser case, it is possible that the anode will be connected to earth ground when the laser is installed in a benchtop mount, or in your laser system. In situations where the laser diode is connected to the case, it is critical that the negative terminal of the power supply remain isolated from earth ground.

FINE TUNE DEEP MODULATION

If the analog modulation input is near the rail (> 4.5 V), output current signal response may be insufficient. Performance may be improved by connecting a low-ESR 330 μF, 16 V, electrolytic capacitor between pins 10 and 13. This decoupling capacitor should be connected at the driver.

CABLE LENGTHS AND HIGH CURRENT

The length and gauge of cable from the power supply or to the laser diode can impact performance. The resistance and inductance of the wire can reduce bandwidth or cause the voltage to the PLD to droop.

Use minimum 14 AWG wire for the laser diode interconnect wires. Always twist the wire pairs to eliminate reactance.

If the output current starts to oscillate as setpoint voltage approaches the limit setting, then the power supply cables may be too long. If you cannot shorten the cables, place a 330 μF capacitor across pins 10 and 13 to minimize droop.

ADD LASER DIODE PROTECTION FOR LONG CABLES

With a cable longer than two feet, add a Schottky diode across the laser diode, see **Figure 15**.

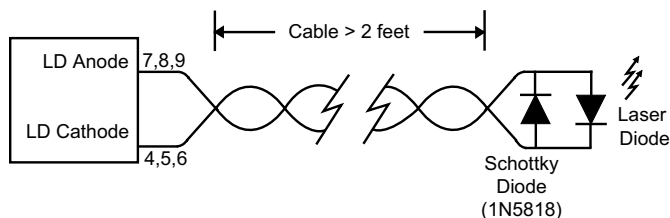

Figure 15. Long Cable Laser Protection

ADDITIONAL NOISE FILTERING

The PLD drivers provide low-noise current to the laser diode, but in some cases additional filtering may be needed. Refer to **Figure 16** for a simple and effective filter.



Figure 16. PLD Output Filter

REVISION A & B TIMING CHARACTERISTICS

Table 4 and **Table 5** describe the timing characteristics of Revisions A and B of the drivers.

Table 4. Output Timing, PLD10000 Revision A

TURN-ON TIME	TURN-OFF TIME	SLOWSTART DELAY
10 µsec	12 µsec	≥1.5 sec

Table 5. Output Timing, Revision B

MODEL	TURN-ON TIME	TURN-OFF TIME	SLOWSTART DELAY
PLD10000	5.3 µsec	9.5 µsec	≥1.5 sec
PLD12500	5 µsec	8 µsec	≥1.5 sec

MONITOR CALIBRATION CIRCUIT

A small offset may be present when measuring the P Monitor, I Monitor or LIM I Monitor voltage with respect to the actual output. Use the circuit shown in **Figure 17** to remove any offset.

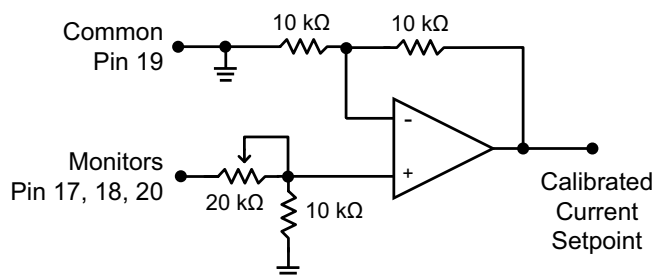

Figure 17. Monitor Calibration Circuit

PRODUCT VARIATIONS

We design and manufacture our products in-house, and that gives us the unique ability to quickly and inexpensively modify our drivers and controllers to suit your application. Our Product Variation service allows us to address your design requests, from prototype quantities to long-term high-volume manufacturing.

Examples of past Product Variations include:

- Replacing current limit trimpots with fixed-value resistors to maximize long-term stability in an OEM laser controller system
- Increasing the maximum output current
- Changing the controller input voltage

OUTPUT ON/OFF AND CURRENT LIMIT TIMING

Figure 18 through Figure 20 illustrate the the output turn-on delay, slowstart turn-on/off time, and current limit response.

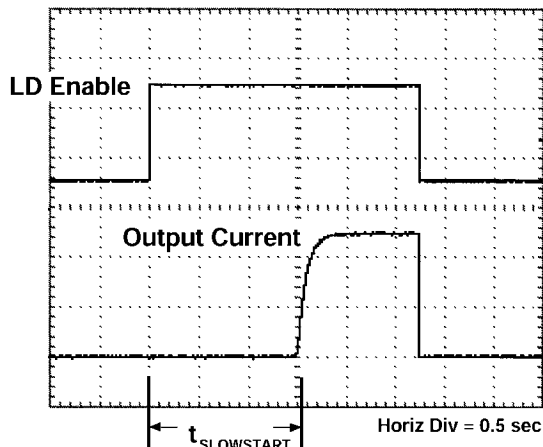

Figure 18. Output Turn-On Delay

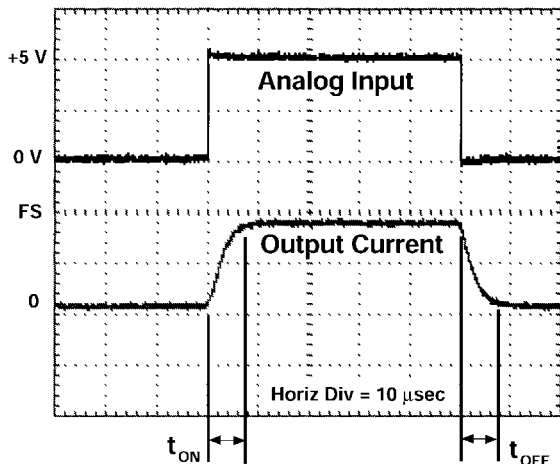

Figure 19. Output On/Off-Time

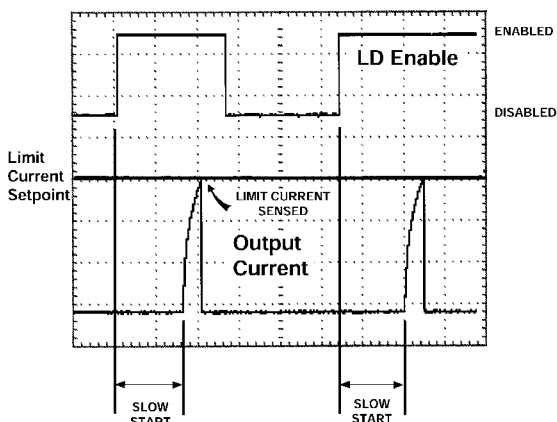

Figure 20. Current Limit Response

SAFE OPERATING AREA CALCULATION

The Safe Operating Area of the PLD driver is determined by the amount of power that can be dissipated within the output stage of the driver. If that power limit is exceeded permanent damage can result.



DO NOT OPERATE THE PLD DRIVER OUTSIDE OF THE SAFE OPERATING AREA CURVE.

OPERATING THE PLD DRIVER OUTSIDE OF THE SOA VOIDS THE WARRANTY.

Refer to the Wavelength Electronics website for the most up-to-date SOA calculator for our products. The online tool is fast and easy to use, and also takes into consideration operating temperature.

<https://www.teamwavelength.com/support/design-tools/soa-ld-calculator/>

SOA charts are included in this datasheet for quick reference, however we recommend you use the online tools instead.

Follow these steps to determine if the driver will be operating within the SOA.

- Refer to the laser diode datasheet to find the maximum voltage (V_{MAX}) and current (I_{MAX}) specifications
- Calculate the voltage drop across the controller:

$$V_{DROP} = V_S - V_{MAX} \quad (V_S \text{ is the power supply voltage})$$

- Mark V_{DROP} on the X-axis, and extend a line upward
- Mark I_{MAX} on the Y-axis, and extend a line to the right until it intersects the V_{DROP} line
- On the X-axis, mark value of V_S
- Extend a diagonal line from V_S to the intersection of the V_{DROP} and I_{MAX} lines; this is the Load Line
- If the Load Line crosses the Safe Operating Area line at any point, the configuration is not safe

If the SOA calculator indicates the PLD will be outside of the Safe Operating Area, the system must be changed so that less power is dissipated within the driver. See Wavelength Electronics Application Note [AN-LDTC01: The Principle of the Safe Operating Area](#) for information on shifting the Load Line.

After changing any of the parameters, recalculate the SOA to make sure the driver will operate safely. If you have questions, or run into difficulties calculating the SOA, contact Wavelength Electronics for assistance.

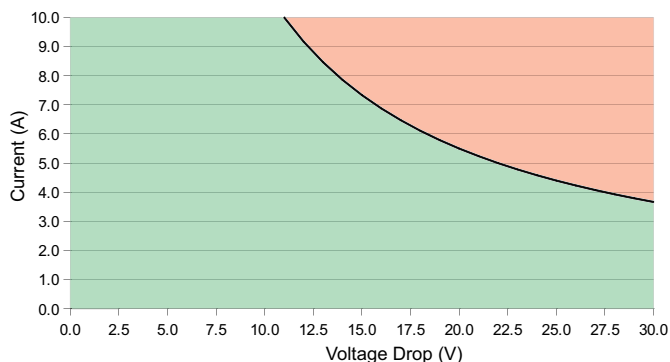

Figure 21. SOA for PLD10000

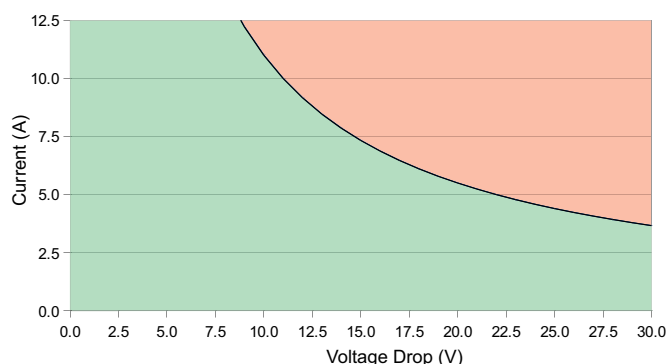

Figure 22. SOA for PLD12500

TROUBLESHOOTING

PROBLEM	POTENTIAL CAUSES	SOLUTIONS
Driver will not switch on	Improperly configured power supply	Carefully check the wiring diagram according to Table 3 . Make sure the polarity of the power supply is correct.
Output will not enable	Remote Enable signal is not correct	Refer to the LD Enable specifications in Table 1 and make sure the LD ENABLE (pin 22) signal is correct.
Laser output power too low in Constant Current mode	Laser current setpoint too low	Increase the setpoint either by adjusting the I OUT ADJ trimpot clockwise, or by increasing the signal voltage on the Analog Input (pin 16).
	Laser current limit set too low	Refer to page 11 for instructions on setting the laser driver current limit.
	Laser drive is compliance limited	Check the laser diode specifications to determine the forward voltage (V_F). Make sure that the PLD is not compliance limited. Refer to the Electrical Specifications table on page 5 . If the driver is compliance limited, $V_{LD\ Anode}$ (pins 7, 8, 9) may need to be increased. Verify that the PLD will be operating within the Safe Operating Area if the supply voltage is increased.
Laser does not reach desired output in Constant Power mode	Current limit set too low	Check the laser diode datasheet to determine the approximate laser drive current at the desired optical power output level. Then verify that the current limit is set slightly higher than that. Refer to page 11 for instructions on setting the laser driver current limit.
	Photodiode feedback current is out of range for the PLD	Refer to the laser diode datasheet to determine the approximate photodiode (PD) current at the desired output power level. If the PD current exceeds the PLD PD current range, set the PD Range switch to High Range (Type A/B laser diodes only.)
	Voltage drop across cables is too high	At high currents the voltage drop across the transmission wires may become an issue. The excessive voltage drop may result in the driver being compliance voltage limited before the drive current setpoint is reached. Use large-gauge wires, and keep the wires as short as possible.

MECHANICAL SPECIFICATIONS

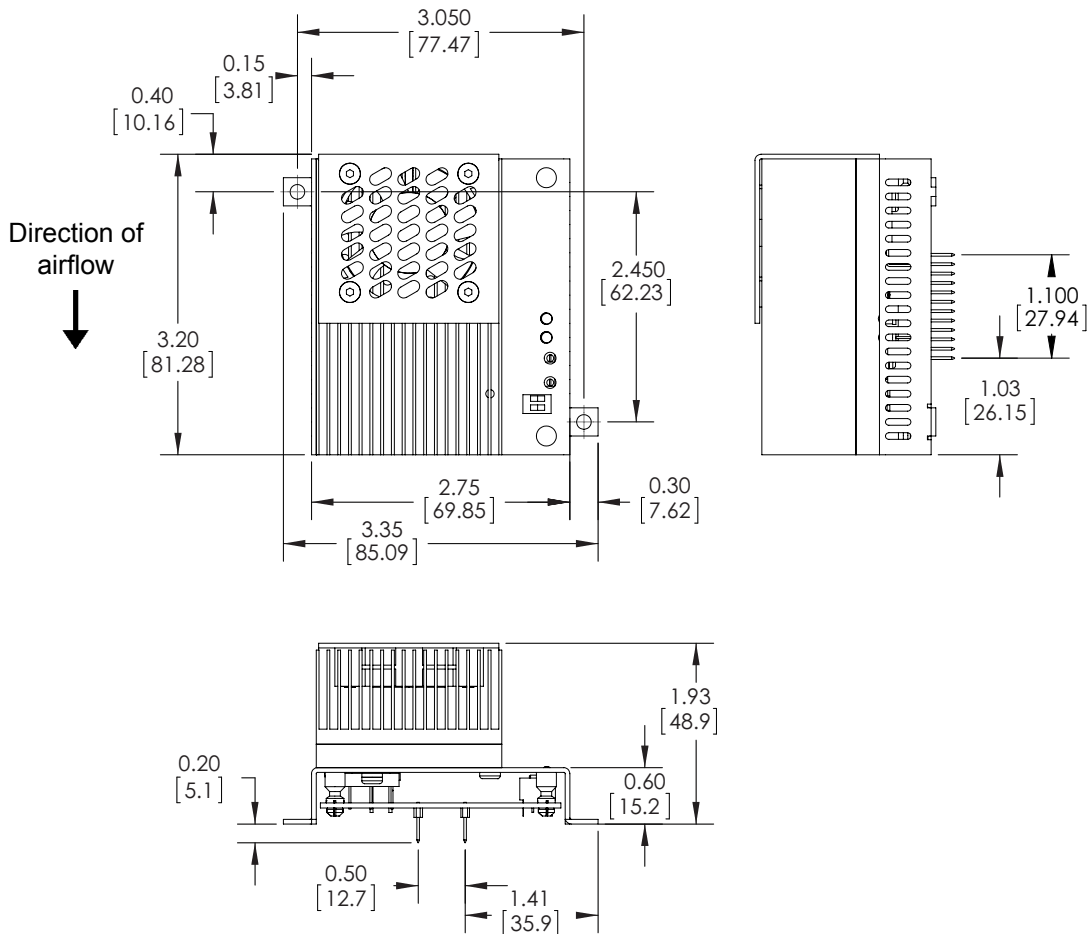

Figure 23. PL10000 / PLD12500 Mechanical Dimensions

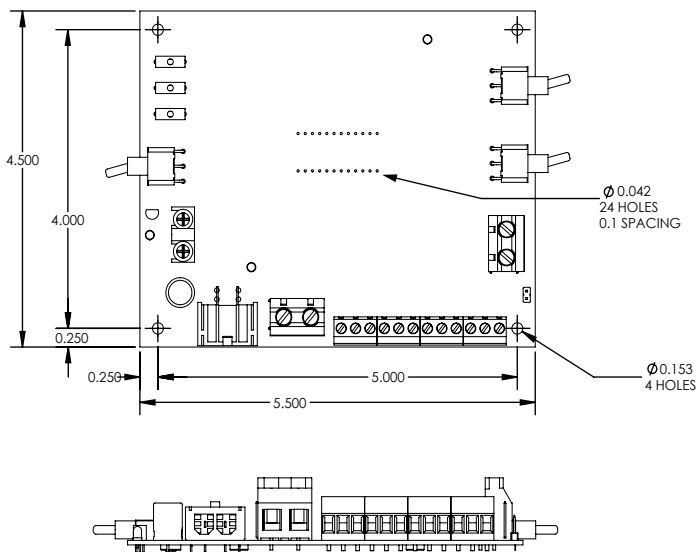

Figure 24. PLD10EV Eval Board Dimensional Layout

All tolerances $\pm 5\%$; units in inches [mm]

CERTIFICATION AND WARRANTY

CERTIFICATION

Wavelength Electronics, Inc. (Wavelength) certifies that this product met its published specifications at the time of shipment. Wavelength further certifies that its calibration measurements are traceable to the United States National Institute of Standards and Technology, to the extent allowed by that organization's calibration facilities, and to the calibration facilities of other International Standards Organization members.

WARRANTY

This Wavelength product is warranted against defects in materials and workmanship for a period of one (1) year from date of shipment. During the warranty period, Wavelength will, at its option, either repair or replace products which prove to be defective.

WARRANTY SERVICE

For warranty service or repair, this product must be returned to the factory. An RMA is required for products returned to Wavelength for warranty service. The Buyer shall prepay shipping charges to Wavelength and Wavelength shall pay shipping charges to return the product to the Buyer upon determination of defective materials or workmanship. However, the Buyer shall pay all shipping charges, duties, and taxes for products returned to Wavelength from another country.

LIMITATIONS OF WARRANTY

The warranty shall not apply to defects resulting from improper use or misuse of the product or operation outside published specifications. No other warranty is expressed or implied. Wavelength specifically disclaims the implied warranties of merchantability and fitness for a particular purpose.

EXCLUSIVE REMEDIES

The remedies provided herein are the Buyer's sole and exclusive remedies. Wavelength shall not be liable for any direct, indirect, special, incidental, or consequential damages, whether based on contract, tort, or any other legal theory.

REVERSE ENGINEERING PROHIBITED

Buyer, End-User, or Third-Party Reseller are expressly prohibited from reverse engineering, decompiling, or disassembling this product.

NOTICE

The information contained in this document is subject to change without notice. Wavelength will not be liable for errors contained herein or for incidental or consequential damages in connection with the furnishing, performance, or use of this material. No part of this document may be translated to another language without the prior written consent of Wavelength.

SAFETY

There are no user-serviceable parts inside this product. Return the product to Wavelength Electronics for service and repair to ensure that safety features are maintained.

LIFE SUPPORT POLICY

This important safety information applies to all Wavelength electrical and electronic products and accessories:

As a general policy, Wavelength Electronics, Inc. does not recommend the use of any of its products in life support applications where the failure or malfunction of the Wavelength product can be reasonably expected to cause failure of the life support device or to significantly affect its safety or effectiveness. Wavelength will not knowingly sell its products for use in such applications unless it receives written assurances satisfactory to Wavelength that the risks of injury or damage have been minimized, the customer assumes all such risks, and there is no product liability for Wavelength. Examples of devices considered to be life support devices are neonatal oxygen analyzers, nerve stimulators (for any use), auto-transfusion devices, blood pumps, defibrillators, arrhythmia detectors and alarms, pacemakers, hemodialysis systems, peritoneal dialysis systems, ventilators of all types, and infusion pumps as well as other devices designated as "critical" by the FDA. The above are representative examples only and are not intended to be conclusive or exclusive of any other life support device.

REVISION HISTORY

DOCUMENT NUMBER: PLD10000-0400

REV.	DATE	CHANGE
E	7-Aug-2012	Added PLD12500 SOA data
F	3-Sep-2012	Updated pin specifications
G	January 2013	Update for Product Revision D
H	November 2013	Added CE mark and extended warranty
I	March 2015	Added airflow direction
J	October 2015	Added Disable Fall Time specification
K	Nov. 2015	Removed relay short from 12.5 A



51 Evergreen Drive
Bozeman, Montana 59771

406-587-4910 (tel)
406-587-4911 (fax)

Sales & Tech Support
sales@teamwavelength.com
techsupport@teamwavelength.com