

Vacuum contactors

RP133 three-phase vacuum contactors

View A-A

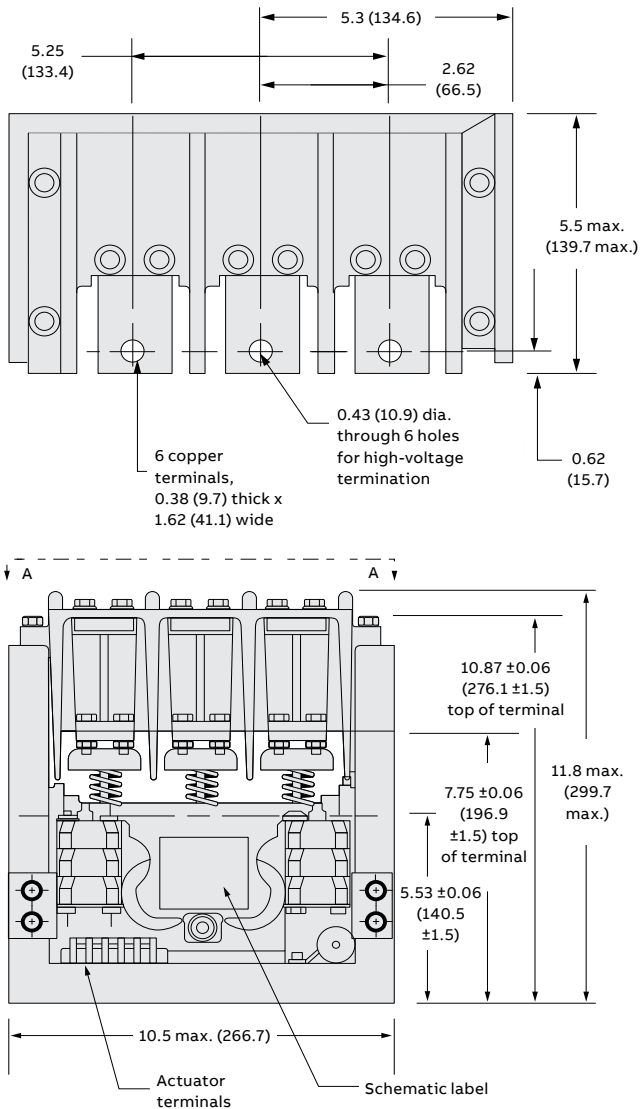

Dimensions shown are in inches (mm).

The Jennings RP133 vacuum contactor may be small – only 11.8"H x 10.5"W x 5.5"D – and weigh less than 30 pounds, but it can take on requirements of the most demanding equipment. Using a trio of Jennings vacuum interrupters, the three-phase unit provides a short contact-to-contact gap required to interrupt the circuit for highly reliable operation. The contact materials are rated for 1.5 kV, 450 A load life and 4500 A fault current.

Designed to withstand the frequent switching required to control furnaces and large air conditioning motors, the RP133 is commonly used to protect power transformers and DC power supplies. Use it to switch capacitor banks for voltage regulation and power factor correction as a means of reducing operating costs. Reliable and durable, the RP133 can also be used in motor controllers that operate production and processing equipment, mining and construction equipment, earth movers or carriers, power shovels, rock crushers and conveyors.

Features

- Sealed main contacts provide a minimum of 1 million maintenance-free open and close operations
- Reliable operation in harsh temperature extremes ranging from -20 °C to 70 °C
- Versatility for use with heavy-duty motors, power equipment and motor controllers



Vacuum contactors

RP133 three-phase vacuum contactors



01

01 Units shown in de-energized position

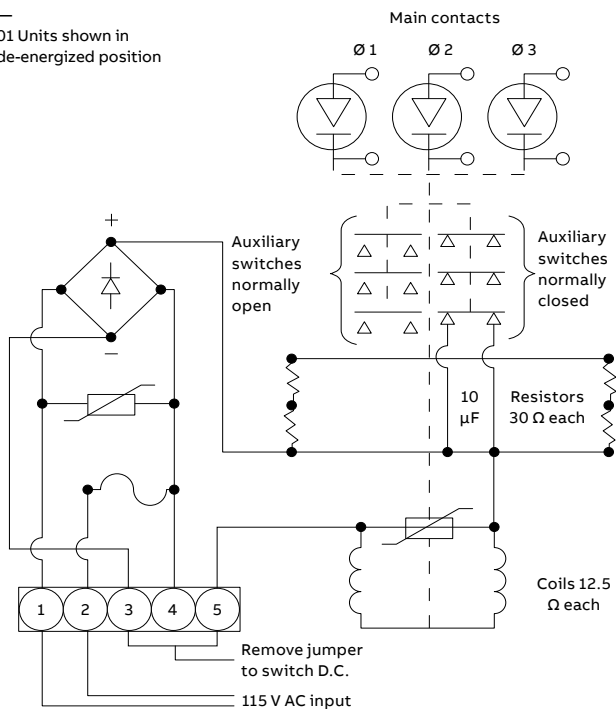

Voltage ratings	
Maximum three-phase line (V and kV)	600 and 1.5
Dielectrics 50/60/400 Hz, 60-second withstand	
- Line-to-ground (kV RMS)	6.5
- Line-to-line (kV RMS)	6.5
- Across open contacts (kV RMS)	6.5
BIL, 1.2 x 50 µsec impulse	
- Line-to-ground peak (kV)	20
- Line-to-line peak (kV)	20
- Across open contacts (kV)	20
Current rating	
Continuous (amps RMS)	450
Load-switching (amps RMS)	450
- Capacitors	750 kVAR at 1.5 kV
- Motors	750 HP at 1.1 kV
Making current (random make)	
- 100 times at 1.5 kV with 3-second backup (kA RMS)	4.5
- 10 times at 1.5 kV with current-limiting fuse (kA)	28 peak
- 100 times at 1.5 kV with 3-second backup (kA RMS)	6
Minimum load life at 450 A RMS	1 million open/close operations
Interrupt (amps RMS at 1.5 kV)	4500
Actuator	
Control voltage	115 V AC, 50/60 Hz or 110 V DC
Control current	7.1 pull-in A, 0.9 hold-in A
Auxiliary contacts configuration	2 N/C, 3 N/O, SPST double break, 10 A resistive at 600 V AC
Mechanical	
Weight (lb.)	30 max.
Release time (msec.) from control switch off to separation of main contacts	16 max.
Mounting	Operates in any position

RP133 three-phase vacuum contactors

Cat. no.	Mounting option	Actuator volts	Line-to-line voltage (RMS)
RP133-2332-00	2332	115 V AC/110 V DC	1500
RP133-2332-01	2332	115 V AC/110 V DC	3300
RP133-2334-00	2334	100 V DC	1500
RP133-2335-00	2335	115 V AC/110 V DC	1500

Vacuum contactors

Overview

Jennings vacuum contactors offer one of the most reliable means available for remotely controlling electric power

—
01 Figure 1— Typical Jennings solenoid-operated vacuum contactor

Jennings vacuum contactors provide all the operating advantages of a vacuum interrupter plus the benefits of a matching actuator to meet specific application requirements. These low and medium voltage contactors offer the most reliable means of remotely controlling electric power.

Maintenance-free vacuum contactors provide fast arc extinction and rapid recovery of dielectric strength

Jennings contactors consist of a vacuum interrupter and an actuator linked together by an insulated actuating rod. Linkage and stand-off posts that isolate the high voltage from ground are made of epoxy glass laminate for DC switching. Heavy-duty connectors are provided for the high voltage connection.

Figure 1 illustrates a solenoid-operated vacuum contactor. Its interrupter consists of an evacuated ceramic insulating envelope in which there are two contacts, one stationary and one movable. The movable contact is operated from the outside through a metallic bellows that provides a vacuum-tight seal.

A vacuum has an extremely high dielectric strength – As high as 1000 V per mil. When the contacts are opened to interrupt current flow, metal vapor is generated by the passage of current through the contacts. The vapor sustains the arc that is created, maintaining it down to or near current zero.

The small arc drawn on the contact opening is quickly extinguished because there are no gases, and there is only a small voltage drop across it. As the arc extinguishes, the metallic vapor rapidly diffuses outward and condenses on the cool surface of the vapor shields. The vapor shields prevent the metallic vapor from depositing on the ceramic insulating surfaces.

Fast arc extinction and rapid recovery of dielectric strength after contact opening are characteristics of vacuum interrupters. A phenomenon with these interrupters is the auto-maintenance of the vacuum. The metallic ions released from the contacts provide a gettering action. Tests have shown that frequent operation of the contacts produces a steady improvement in vacuum level because the released metallic ions actually remove gas molecules from the evacuated space. This ion-pumping action tends to maintain the vacuum near the high initial value.

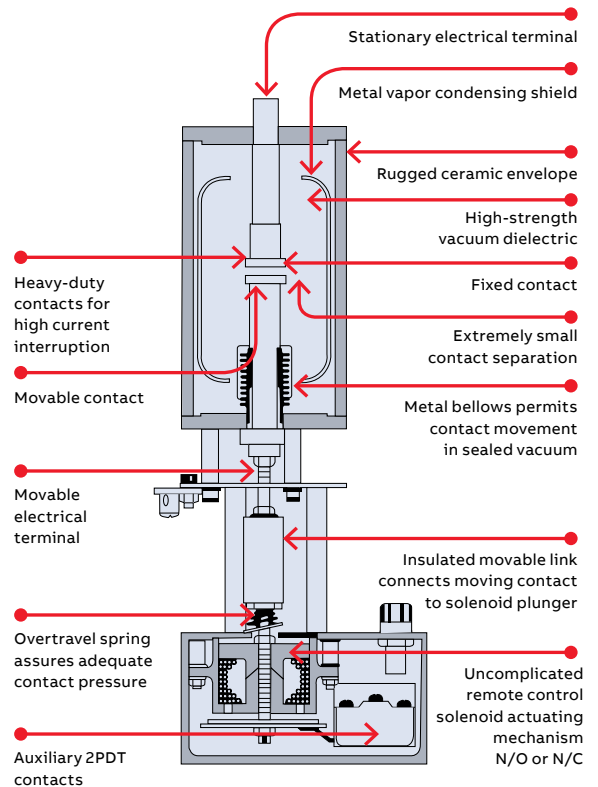

Vacuum contactors

Overview

Typical applications

Jennings vacuum power contactors are used for controlling DC and 50/60/400 Hz circuits. Principal use is in high power electrical equipment requiring long contact life without maintenance, low-cost, high voltage control or sealed contacts because of environmental conditions.

Switching and protecting transformers used in DC power supplies is one of the most common power frequency applications for contactors. Most transformer switching is done on the primary side for off-on control or to switch out current-limiting resistors or reactors used for reduced-voltage starting of power tubes. It may be necessary to use additional backup fault protection to take care of primary line-side faults. This is sometimes accomplished using a current-limiting fuse or coordinating with a high capacity system breaker already located in the primary side. However, where frequent faults are anticipated, contactors offer a much longer life with no contact maintenance, and they are often less expensive.

Advantages of Jennings vacuum contactors

By employing proven Jennings vacuum interrupter technology, Jennings contactors provide reliable, maintenance-free operation in industrial motor controls and other systems using a wide range of currents and voltages. The operation of contacts within a vacuum offers several inherent advantages:

- No required contact maintenance – Contacts are sealed within a very high vacuum and remain clean permanently. There is no contact oxidation or possibility of foreign matter forming on the contacts and leaving contaminating residues.
- Long life – The arc that results as the contact is made or broken is quickly extinguished within a vacuum. The special contact material utilized erodes at an extremely slow rate to provide reliable operation for tens of thousands of operations.
- Environmental safety factor – Vacuum contactors can be used in environments involving corrosive atmospheres because there is no exposed arcing during interruption.
- Compact, reliable operating mechanism – The high dielectric strength of a vacuum minimizes the contact-to-contact gap required to interrupt current. This short contact stroke not only provides high operating speed, but also reduces the size and weight of the operating mechanism used.
- No arc chute replacement – Ordinary air-break contactors require fragile arc chutes to extinguish the arc that forms when the contact is broken. Arc chutes are damaged with use and ultimately require replacement. The manner in which vacuum contactors operate causes the arc to be extinguished rapidly with minimal damage or wear.
- Proven operation – Jennings vacuum interrupters have been supplied for several decades for use in electrical power generation and distribution systems operating at all voltage levels. The long life and reliability of these devices is such that many of the original units are still in operation.
- Low contact resistance – This resistance remains low and stable for the life of the contactor.

