

Lytron's standard tubed cold plates provide cost-effective thermal solutions for component cooling applications where the heat load is low-to-moderate. Our tubed cold plates consist of copper or stainless steel tubes pressed into a channeled aluminum extrusion.

- **Superior thermal performance:** Our tubed cold plates are manufactured using Lytron's proprietary Press-Lock technology, which mechanically locks the tubes into the aluminum plate. Press-Lock technology eliminates the need for performance-limiting epoxy between the tube and the plate, resulting in superior thermal performance. Compared to similar tubed cold plates, the CP12 cold plate offers 30% better performance and the CP15 offers 40% to 50% better performance.
- **Compatible with water and a range of coolants:** Copper tubes are compatible with water and most other common coolants, while stainless steel tubes can be used with deionized water or corrosive fluids.
- **Reliable and leak-free:** Each tubed cold plate has a single tube with no joint, ensuring leak-free operation.
- **Dual-sided mounting option:** The tubes of the CP12 and CP15 cold plates are coplanar with the plate to allow for dual-sided mounting. The cold plate's tube side offers higher performance as the copper tubes are in direct contact with the component being cooled.

Model	Tube Material	Configuration	Mounting	Tube Diameter
CP10	Copper or Stainless Steel	2-Pass or 4-Pass	Single-Sided	3/8" (9.5 mm) OD Tubing
CP12	Copper	4-Pass	Dual-Sided	3/8" (9.5 mm) OD Tubing
CP15	Copper	6-Pass	Dual-Sided	1/4" (6.4 mm) OD Tubing

Please review our specifications table on page 39 for complete standard tubed cold plate model numbers.

☞ *Press-Lock cold plate with custom machining and custom tube configuration*



Customization Options

The CP10, CP12, and CP15 tubed cold plates can be drilled, tapped, or surface-machined according to your requirements. Other customizations, such as variations in dimensions, fittings, and tubing configuration, are available for OEM volumes.

See page 30 for more custom cold plates.



-  DWG 38
-  GRAPHS 39
-  SPECS 39
-  SELECT 40

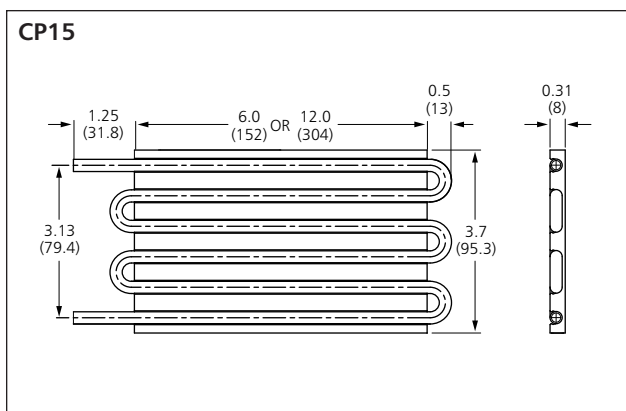
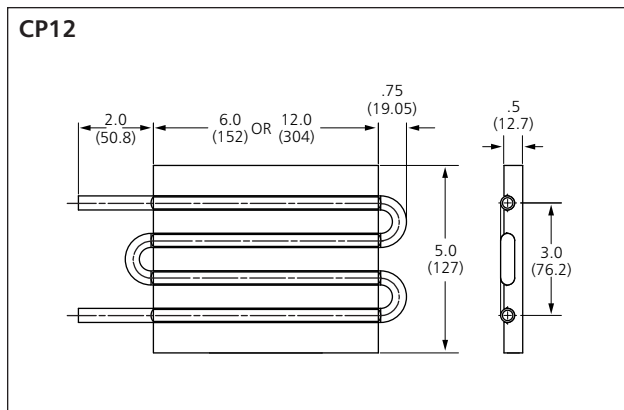
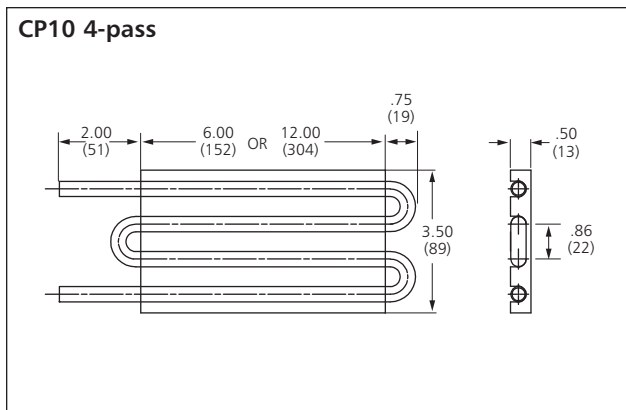
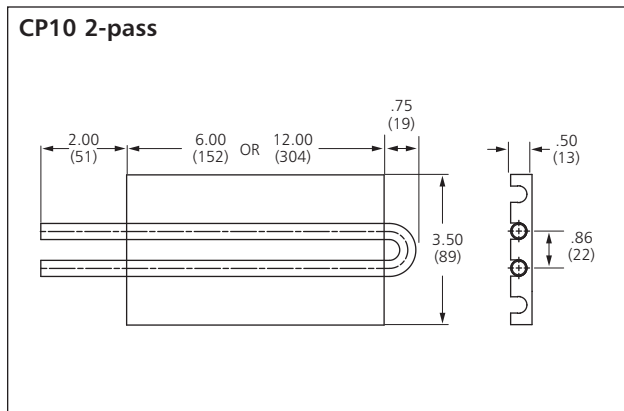
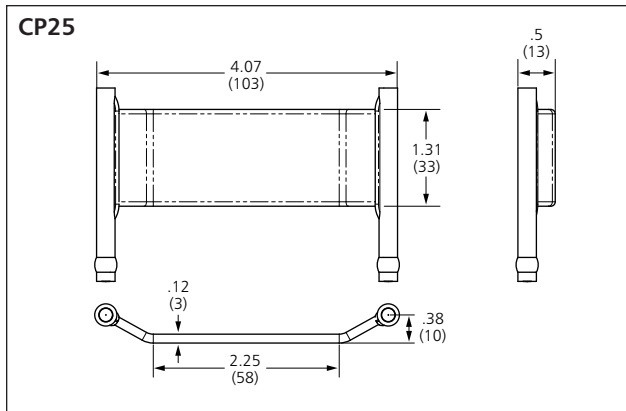
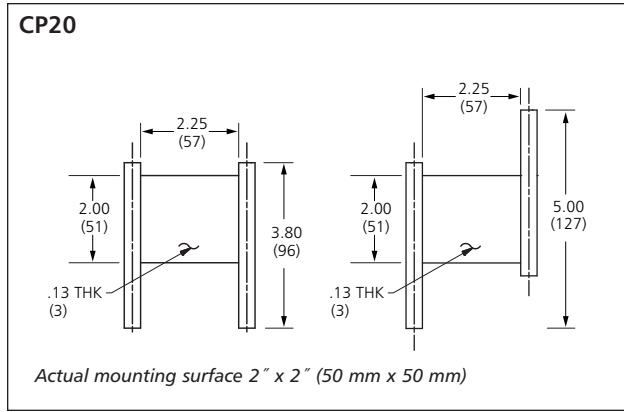
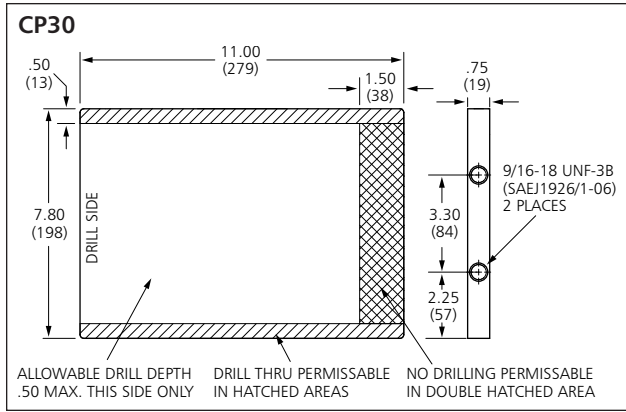

PDFs, IGS files, and eDrawings of standard cold plates are available at www.Lytron.com. Main dimensional label is inches. Dimension in parentheses is mm.

Thermal resistance is normally expressed as °C per Watt. Thermal resistance describes how much hotter the surface of a cold plate is relative to the temperature of the fluid flowing through the cold plate, under a given thermal load. Our performance curves show the local thermal resistance—the surface temperature versus the local liquid temperature. Full details on thermal resistance calculations and how to select a cold plate technology are on page 40.

Normalized performance graphs

This graph shows the **normalized** thermal resistance for our standard cold plate products (i.e. thermal impedance per square inch). It enables cold plate technologies to be compared independently of individual part geometries. The lower the thermal impedance, the better the performance of the cold plate.

1. Thermal resistance is inversely proportional to area. To find the thermal resistance of a 25 inch² (161 cm²) cold plate, divide the normalized performance by 25.
2. Our CP30 standard cold plate is designed for prototyping purposes, so it has a thick surface plate for machining. We show two traces—before (0.5"/13 mm) and after (0.05"/1.3 mm) machining. The performance of a custom vacuum-brazed cold plate is usually significantly better than the standard part.
3. For comparison purposes, the performance of all cold plates is shown using water as the coolant. Treated water is recommended with aluminum (CP20 & CP30) cold plates.
4. Please visit www.Lytron.com for individual cold plates' thermal performance, pressure drop graphs, weight, and fluid volume.

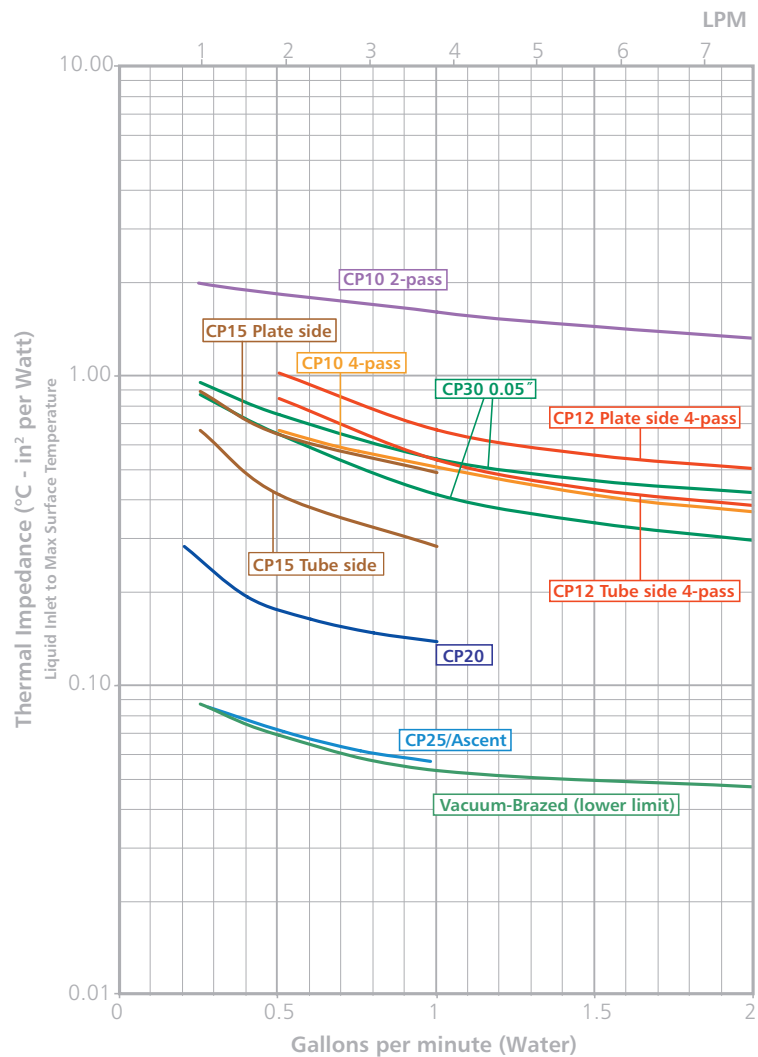

Cold Plate Specifications & Fittings*

Model	Tubed Material	Tube Diameter	Configuration	Fitting	Mounting Surface
CP30G01	Aluminum	NA	Square	9/16-18 UNF-3B	7.8" x 11" (19.81 cm x 27.94 cm)
CP20G01/G02	Aluminum	3/8" (9.5 mm)	U	Straight or Beaded*	2" x 2" (5.08 cm x 5.08 cm)
CP20G03/G04	Aluminum	3/8" (9.5 mm)	Z	Straight or Beaded*	2" x 2" (5.08 cm x 5.08 cm)
CP25G01/G02	Copper	1/4" (6.4 mm)	U	Straight or Beaded*	2.25" x 1.3" (5.72 cm x 3.30 cm)
CP10G01/G02	Copper	3/8" (9.5 mm)	2-Pass	Straight or Beaded*	6" x 3.5" (15.24 cm x 8.89 cm)
CP10G03/G04	Stainless Steel	3/8" (9.5 mm)	2-Pass	Straight or Beaded*	6" x 3.5" (15.24 cm x 8.89 cm)
CP10G05/G06	Copper	3/8" (9.5 mm)	2-Pass	Straight or Beaded*	12" x 3.5" (30.48 cm x 8.89 cm)
CP10G07/G08	Stainless Steel	3/8" (9.5 mm)	2-Pass	Straight or Beaded*	12" x 3.5" (30.48 cm x 8.89 cm)
CP10G14/G15	Copper	3/8" (9.5 mm)	4-Pass	Straight or Beaded*	6" x 3.5" (15.24 cm x 8.89 cm)
CP10G16/G17	Stainless Steel	3/8" (9.5 mm)	4-Pass	Straight or Beaded*	6" x 3.5" (15.24 cm x 8.89 cm)
CP10G18/G19	Copper	3/8" (9.5 mm)	4-Pass	Straight or Beaded*	12" x 3.5" (30.48 cm x 8.89 cm)
CP10G20/G21	Stainless Steel	3/8" (9.5 mm)	4-Pass	Straight or Beaded*	12" x 3.5" (30.48 cm x 8.89 cm)
CP12G01/G02	Copper	3/8" (9.5 mm)	4-Pass	Straight or Beaded*	6" x 5" (15.24 cm x 12.70 cm)
CP12G05/G06	Copper	3/8" (9.5 mm)	4-Pass	Straight or Beaded*	12" x 5" (30.48 cm x 12.70 cm)
CP15G01/G02	Copper	1/4" (6.4 mm)	6-pass	Straight or Beaded*	6" x 3.75" (15.24 cm x 9.53 cm)
CP15G05/G06	Copper	1/4" (6.4 mm)	6-pass	Straight or Beaded*	12" x 3.75" (30.48 cm x 9.53 cm)

* Letter G followed by an odd number indicates straight fittings and letter G followed by an even number indicates beaded fittings. For example, part number CP20G01 has a straight fitting and CP20G02 has a beaded fitting.

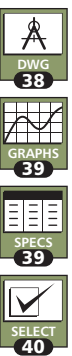

Selecting a Cold Plate Technology

To select the best cold plate for your application, you need to know the cooling fluid flow rate, the fluid inlet temperature, the heat load of the devices attached to the cold plate, and the maximum desired cold plate surface temperature, T_{max} . From these you can determine the maximum allowable thermal resistance of the cold plate.

First, calculate the maximum temperature of the fluid when it leaves the cold plate, T_{out} . This is important because if T_{out} is greater than T_{max} , there is no solution to the problem.

T_{out} can be calculated by solving the heat capacity equation:

$$T_{out} = T_{in} + \frac{Q}{\rho \cdot \dot{v} \cdot C_p}$$

T_{out} = temperature of fluid leaving cold plate
 T_{in} = inlet temperature of fluid
 Q = heat load of devices
 ρ = density of the fluid
 \dot{v} = cooling fluid flow rate
 C_p = specific heat of the fluid

Alternatively, you can use the heat capacity graphs found on www.Lytron.com. These graphs describe the change in temperature, ΔT , that occurs along the fluid path. To find T_{out} , add ΔT to the inlet temperature, T_{in} .

Assuming T_{out} is less than T_{max} , the next step is to determine the required normalized thermal resistance (θ) for the cold plate using this equation:

$$\theta = (T_{max} - T_{out}) \cdot (A/Q)$$

θ = thermal impedance
 T_{max} = maximum desired cold plate surface temperature
 T_{out} = temperature of fluid leaving cold plate
 A = area being cooled
 Q = heat load of devices

Any cold plate technology that provides a normalized thermal impedance less than or equal to the calculated value will be a suitable solution.

Example:

A cold plate is used to cool a 2" x 4" (5.08 cm x 10.16 cm) IGBT that generates 500 W of heat. It is cooled with 20°C water at a 0.5 gpm flow rate. The surface of the cold plate must not exceed 55°C.

We know:

T_{in} : 20°C T_{max} : 55°C Q : 500 Watts A : 8 in²

We need to calculate T_{out} and θ .

First calculate T_{out} . Using the heat capacity graphs on www.Lytron.com, we find that the temperature change for 500 W at a 0.5 gpm flow rate is 4°C. Therefore $T_{out} = 20°C + 4°C = 24°C$.

T_{out} is less than T_{max} so we can proceed to the second part of the problem. The required thermal impedance is given by this equation:

$$\theta = (T_{max} - T_{out}) \cdot (A/Q) \quad \theta = (55°C - 24°C) \cdot (8 \text{ in}^2 / 500 \text{ W})$$

$$\theta = 0.5°C \cdot \text{in}^2 / \text{W} \text{ at } 0.5 \text{ gpm}$$

We then plot this point on the normalized thermal impedance graph. Any technology below this point will meet the thermal requirement. The CP15, CP20, CP25, and CP30 provide the necessary thermal impedance. However, because the cooling fluid is water, you should only consider the CP15 and CP25 cold plates.

