

# DATASHEET AND OPERATING GUIDE

# PTCxK-CH Series

## Chassis Mount Temperature Controllers

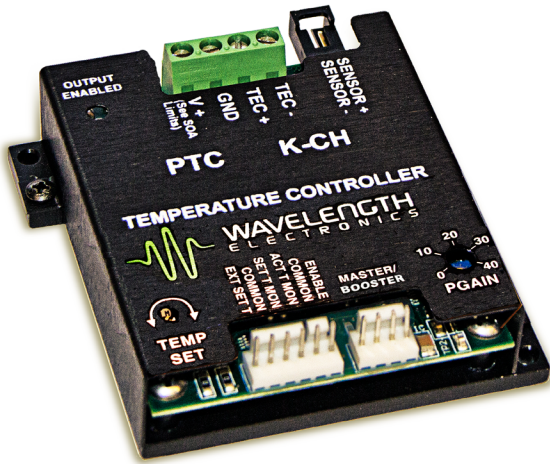

### FEATURES AND BENEFITS

- Drive up to  $\pm 2.5$ ,  $\pm 5.0$ , or  $\pm 10.0$  A of linear bipolar TEC or heater current
- Add a booster unit to drive up to  $\pm 20.0$  A
- Single supply operation: 5 to 30 VDC
- Small package: 3.0" x 3.2" x 1.1"
- Use a wide variety of temperature sensors
- Remote Output and Setpoint controls
- Short term stability:  $0.0012^{\circ}\text{C}$
- Long term stability:  $0.002^{\circ}\text{C}$
- Selectable sensor bias current
- Adjustable current limit
- Failsafe Setpoint default in case of remote temperature setpoint signal error

### TIME-TESTED RELIABILITY

The PTCxK-CH Series Chassis Mount Temperature Controllers deliver the precision performance and long-term reliability you expect from a Wavelength Electronics temperature controller.

### APPLICATIONS

PTCxK-CH Series controllers are found in such diverse applications as particle and droplet measurement, manufacturing machine vision systems, biomolecular interaction analysis, and more.

### VERSATILE AND EASY TO USE

The PTCxK-CH controllers operate from a single power supply between 5 V and 30 V. The linear bipolar controller drives a Peltier thermoelectric cooler or a resistive heater, and integrates easily into OEM applications.

PTCxK-CH controllers interface with a variety of temperature sensors, and the bias current is adjustable in order to maximize controller sensitivity and stability.

The compact chassis mount design simplifies heatsinking and requires minimal space. PTCxK-CH controllers are quick to configure for your prototype project, and there are no surprises when it's time to integrate the controller into the final design.

### CONTENTS

	PAGE
QUICK CONNECT GUIDE	2
PIN DESCRIPTIONS	3
ELECTRICAL SPECIFICATIONS	4
SAFETY INFORMATION	5
OPERATING INSTRUCTIONS	6
ADDITIONAL TECH NOTES	14
TROUBLESHOOTING	17
CABLE SPECIFICATIONS	19
MECHANICAL SPECIFICATIONS	20
CERTIFICATION AND WARRANTY	21

### ORDERING INFORMATION

PART NO	DESCRIPTION
PTC2.5K-CH	$\pm 2.5$ A Temperature Controller
PTC5K-CH	$\pm 5.0$ A Temperature Controller
PTC10K-CH	$\pm 10.0$ A Temperature Controller
PTC10K-BOOST	$\pm 10.0$ A Booster Unit
WCB105	Sensor Cable (included)
WCB106	Input / Output Cable (included)
WCB107	Power / TEC Cable
WCB501	Master / Booster Cable
USBKIT	USB Interface kit, with software



# QUICK CONNECT GUIDE



TO ENSURE SAFE OPERATION OF THE PTCxK-CH CONTROLLER, IT IS IMPERATIVE THAT YOU VERIFY THAT THE UNIT WILL BE OPERATING WITHIN THE INTERNAL HEAT DISSIPATION SAFE OPERATING AREA (SOA).

Visit the Wavelength Electronics website for the most accurate, up-to-date, and easy to use SOA calculator:

[www.teamwavelength.com/support/design-tools/soa-tc-calculator/](http://www.teamwavelength.com/support/design-tools/soa-tc-calculator/)

Figure 1 is a top view of the PTCxK-CH, showing the trim pots and connector identifiers. Configuring the PTC for operation with remote controls, or changing the sensor bias current, requires the cover be removed; refer to page 9.

Figure 3 is the Quick Connect schematic for TEC operation using a Negative Temperature Coefficient (NTC) sensor. Refer to page 7 and page 8 for additional wiring diagrams.

We recommend using a test load and simulated thermistor when configuring the PTCxK-CH; see Figure 2. The thermistor test load simulates a 10 kΩ thermistor operating at 25°C ± 5°C.

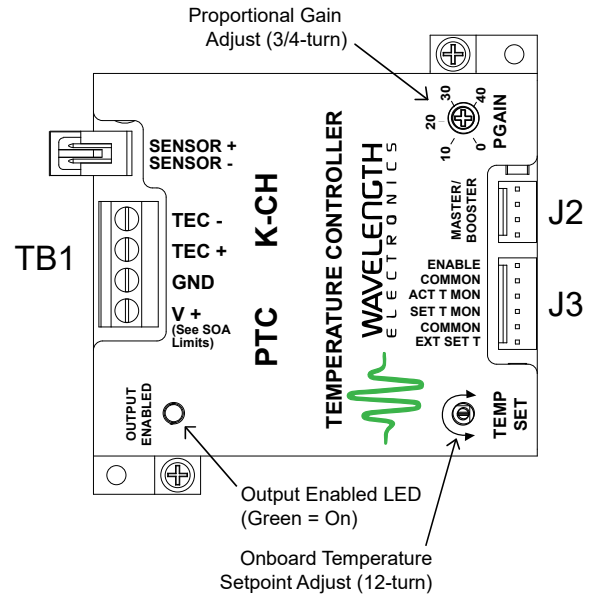

Figure 1. Top View of PTCxK-CH

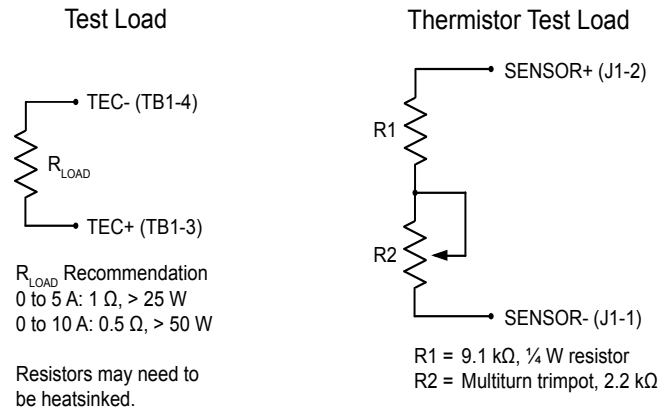
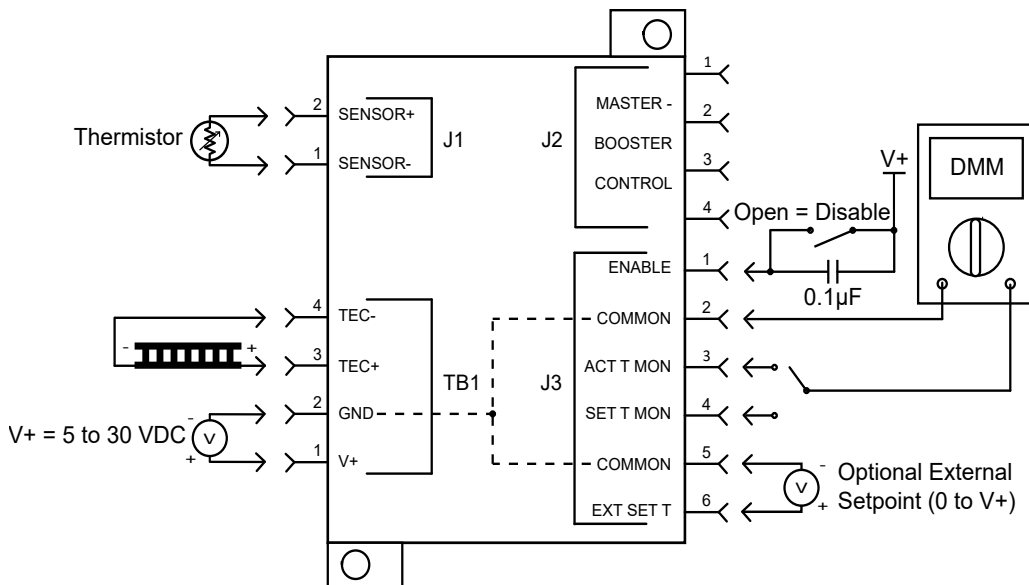

Figure 2. Load and Thermistor Test Circuits



Use caution when the PTC is combined with a PLD laser driver: if the TEC or thermistor is connected to the laser diode, two power supplies may be required and must float independently of each other.

Figure 3. Wiring Diagram for TEC Operating with Negative Temperature Coefficient Sensor

## PIN DESCRIPTIONS

Table 1. Pin Descriptions and Wire Colors

PIN	NAME	CABLE COLOR	PIN DESCRIPTION
Connector TB1, WCB107 Power / TEC Cable			
1	V+	Red	Power supply input, 5 – 30 VDC. The power supply must be rated to drive at least 1.1-times the TEC module plus PTC quiescent current. <b>Verify internal heat dissipation stays within the Safe Operating Area calculator.</b>
2	GND	Black	Power supply ground. <b>This is the only ground connection designed as a high current return.</b>
3	TEC +	Orange	Positive side of TEC. <b>Refer to the operating instructions for proper connections to a TEC or Resistive Heater based on the type of sensor being used.</b>
4	TEC–	Yellow	Negative side of TEC.
Connector J1, WCB105 Sensor Cable (included)			
1	SENSOR–	Black	Negative side of temperature sensor. Internally connected to COMMON and GND. <b>This pin is intended as a low-current return only.</b>
2	SENSOR+	Red	Positive side of temperature sensor. Bias current is driven from SENSOR+ to SENSOR– according to the bias current jumper setting (see <b>page 9</b> ). If the AD590 sensor jumper is in place, the input impedance on pin J1:2 is 10 k $\Omega$ (see <b>page 9</b> ).
Connector J2, WCB501; included with Booster Unit only			
1 - 4	Master / Booster		Master / Booster connector, used to connect Master connector J2 to Booster connector J2. The ends of the cable are interchangeable.
Connector J3, WCB106 Input / Output Cable (included)			
1	ENABLE	Red	Remote Enable. <b>Disable</b> = Ground or <1.45 V. <b>Enable</b> = >3.4 V up to V <sub>DD</sub> or V+ (+5 to +30 V). The Remote Enable is TTL-compatible.
2	COMMON	Black	Common reference ground. <b>Do not use for high current return.</b>
3	ACT T MON	White	Actual temperature sensor voltage monitor. Range 0 to 6 V. When the temperature is stabilized at the setpoint the ACT T MON voltage will closely match the voltage at SET T MON (pin 4). Impedance 1 k $\Omega$ .
4	SET T MON	Blue	Temperature setpoint voltage monitor. Range 0 to 6.2 V and will match the voltage across the sensor when the load is stable at the set temperature. Impedance 1 k $\Omega$ .
5	COMMON	Green	Common reference ground. <b>Do not use for high current return.</b>
6	EXT SET T	Orange	External Temperature Setpoint voltage. Used for remote voltage control of the temperature setpoint. The jumper on the controller top panel must be properly configured for this input to be recognized. The EXT SET T voltage does not sum with the onboard trimpot setting. If the signal falls below 0.3 V the setpoint will default to 1 V (contact factory for alternate default settings).

Table 2. Control and Monitor Transfer Functions

FUNCTION	PTC2.5K-CH	PTC5K-CH	PTC10K-CH	DESCRIPTION
Limit Monitor	0.4 V / A	0.2 V / A	0.1 V / A	Current limit monitor test point, located internally.
EXT SET T		1 V / V		The controller drives the TEC or heater to make the voltage across the sensor match the EXT SET T voltage.
SET T MON		1 V / V		The setpoint temperature monitor voltage matches the setpoint voltage.
ACT T MON		1 V / V		The actual temperature monitor voltage matches the voltage drop across the temperature sensor.

## ELECTRICAL SPECIFICATIONS

PARAMETER	SYMBOL	PTC2.5K	PTC5K	PTC10K	UNIT	NOTE
<b>ABSOLUTE MAXIMUM RATINGS</b>						
Supply Voltage	V+		4.5 to 30		VDC	<a href="#">Consult Safe Operating Area calculator.</a>
Internal Power Dissipation <sup>1</sup>	P <sub>MAX</sub>		60		W	derating begins at 55°C
Case Operating Temperature			-40 to 85		°C	
Case Storage Temperature			-65 to 125		°C	
Weight			4.3		oz	120.4 g
Size			3.00 x 3.18 x 1.11		inches	76.2 x 80.9 x 28.2 mm

PARAMETER	SYMBOL	PTC2.5K	PTC5K	PTC10K	UNIT	NOTE
<b>OUTPUT CURRENT</b>						
Max Output Current	I <sub>MAX</sub>	±2.5	±5	±10	A	V+ = 5 VDC
Minimum Compliance Voltage	V <sub>COMP</sub>	V+ - 1.5	V+ - 2.2	V+ - 4.5	V	V+ > 5.3 VDC
Short Term Stability, 1 hr, Off ambient <sup>1,2,3</sup>			< 0.0012		°C	
Short Term Stability, 1 hr, On ambient <sup>1,2,3</sup>			< 0.0014		°C	10 kΩ thermistor at 100 μA bias current
Long Term Stability, 24 hr, Off ambient <sup>1,2,3</sup>			< 0.002		°C	
Temperature Coefficient			< 100		ppm / °C	

**POWER SUPPLY**

Power Supply Voltage	V+		5 to 30		VDC	
PTC Quiescent Current			50		mA	
Minimum Current Rating			1.1 * (I <sub>TEC</sub> + Quiescent Current)		A	

**TEMPERATURE SENSORS**

Sensor Compatibility		Thermistor, RTD, Linear Sensors				
Sensor Input Voltage Range			0 to (V+ - 1.5) 0 to 5.5		V	V+ < 7 VDC V+ ≥ 7 VDC
Sensor Input Damage Threshold			5.5		V	

**BIAS CURRENT**

Bias Current Selection		10 μA, 100μA, 1 mA, 10 mA				
Bias Current Accuracy			±0.5%			over full temperature range
Bias Current Temperature Coefficient			25 10		ppm / °C	V+ < 7 VDC V+ ≥ 7 VDC

**EXTERNAL SETPOINT AND MONITORS**

External Setpoint Voltage Range			0 to V+ 0 to 6.2		V	V+ < 7 VDC V+ ≥ 7 VDC
External Setpoint Damage Threshold			< -0.5, or > 7.2		V	
SET T MON Output Voltage Range			0 to 6.2		V	
ACT T MON Output Voltage Range			0 to 6		V	
Sensor Voltage to ACT T MON Accuracy			1		mV	
SET T MON to ACT T MON Accuracy			1		mV	

**FEEDBACK LOOP**

Proportional Gain Range			5 to 40		A / V	
Integrator Time Constant		1.7	1.5	1.8	A / V-s	can be changed at factory

<sup>1</sup>) Assumes steady-state operation with a tuned system, using a 10 kΩ thermistor, and P<sub>GAIN</sub> tuned to critical damping point.

<sup>2</sup>) Use the lowest-noise power supplies available for your application. Contact the factory for recommendations.

<sup>3</sup>) When using resistive heaters, stability can only be consistently achieved when specified temperatures are 10°C or more above ambient.

## SAFETY INFORMATION

### SAFE OPERATING AREA – DO NOT EXCEED INTERNAL POWER DISSIPATION LIMITS

Before attempting to operate the PTCxK-CH Controller, it is imperative that you first determine that the unit will operate within the *Safe Operating Area* (SOA). Operating the unit outside of the SOA may damage the controller or the load. Operating outside of the SOA will void the warranty.

To determine if the PTCxK-CH Controller is suitable for your application and if it will be operating in the safe range, consult the online instructions for calculating the Safe Operating Area:

[www.teamwavelength.com/support/design-tools/soa-tc-calculator/](http://www.teamwavelength.com/support/design-tools/soa-tc-calculator/)

SOA charts are included in this datasheet for quick reference (**page 16**), but we recommend you use the online tools instead.



TO ENSURE SAFE OPERATION OF THE PTCXK-CH CONTROLLER, IT IS IMPERATIVE THAT YOU DETERMINE IF THE UNIT IS GOING TO BE OPERATING WITHIN THE INTERNAL HEAT DISSIPATION SAFE OPERATING AREA (SOA).

If you have any questions about the Safe Operating Area calculator call the factory for free and prompt technical assistance.

## THEORY OF OPERATION

The PTCxK-CH Series are high-current linear temperature controllers that deliver bidirectional current to Peltier Effect thermoelectric coolers, or unidirectional current to resistive heaters.

The fundamental operating principle is that the controller adjusts the TEC drive current in order to change the temperature of the sensor that is connected to the thermal load. The goal is to make the voltage across the sensor match the setpoint voltage, and then keep them equal in spite of changes to ambient conditions and variations in thermal load.

The controller measures the load temperature by driving a current through the temperature sensor and measuring the voltage drop across it. It may be useful to remember that you do not directly adjust the setpoint temperature. Rather, you adjust a voltage signal that represents the sensor voltage at the desired temperature setpoint.

While output is enabled, the controller continuously compares the setpoint voltage and the actual sensor voltage. If there is a difference between the two signals the controller adjusts the output current—thereby driving the TEC or heater to change temperature—until the difference is zero.

Once the actual sensor voltage equals the setpoint voltage, the controller makes minor adjustments to the output current in order to keep the difference at zero. If the ambient temperature changes, for example, the controller will adjust the drive current accordingly.

The controller includes features that help protect the load from damage, and also make it more versatile in a wide array of applications.

- **Current limit:** the adjustable current limit must be set correctly in order to avoid over-driving and damaging the TEC or heater.
- **External and Onboard temperature setpoint control:** for prototyping and benchtop applications the temperature setpoint can be adjusted with the onboard trimpot. When the controller is integrated in an automated control system the temperature setpoint can be adjusted by a remote voltage signal.
- **Remote Enable and Local Enable:** the controller can be configured to use a remote signal to enable the output, or it can be configured so that the output is always on whenever power is applied to the unit.
- **Control loop:** the controller employs a smart Proportional-Integrating control loop to adjust the drive current. The proportional term is user-adjustable, and when properly configured will quickly settle the load temperature with minimal overshoot and ringing.

## OPERATING INSTRUCTIONS

These instructions are written for the most common operational mode of the PTCxK-CH controllers: driving a thermoelectric cooler with a thermistor temperature sensor.

The controller is first configured for local control in order to set the drive current limit. Then the controller is reconfigured according to the actual application.

We recommend using a test load until you are familiar with operation of the controller. Refer to **Figure 2** for TEC and thermistor test circuits.

## NECESSARY EQUIPMENT

- PTCxK-CH controller
- Digital multimeter (DMM), 4-½ digit resolution recommended
- Power supply, 5 – 30 VDC, current rated for 1.1-times the TEC current plus PTCxK-CH quiescent current
- Thermistor or other temperature sensor
- Peltier-type thermoelectric module or resistive heater
- Heatsink, mounting hardware, thermal washers, or thermal paste
- Connecting wires
- Test Loads

## SAFE OPERATING AREA AND THERMAL DESIGN CONSIDERATIONS

SOA charts are included in this datasheet for quick reference, but we recommend you use the online tools instead:

[www.teamwavelength.com/support/design-tools/soa-tc-calculator/](http://www.teamwavelength.com/support/design-tools/soa-tc-calculator/)



IT IS IMPERATIVE THAT YOU VERIFY THE UNIT WILL OPERATE WITHIN THE INTERNAL HEAT DISSIPATION SAFE OPERATING AREA (SOA).

OPERATING OUTSIDE THE SOA MAY DAMAGE OR DESTROY THE PTCxK-CH AND/OR LOAD.

If you have any questions about the Safe Operating Area calculator call the factory for free and prompt technical assistance.

When you assemble and mount the TEC (or heater), heatsink, and temperature sensor, make sure the physical connections between the components are solid. We recommend using thermal paste or thermal washers at the load/TEC and TEC/heatsink interfaces. The thermistor must be in firm contact with the load in order to achieve stable and reliable temperature control.

## PREVENT DAMAGE FROM ELECTROSTATIC DISCHARGE

Before proceeding, it is critical that you take precautions to prevent electrostatic discharge (ESD) damage to the controller and load. ESD damage can result from improper handling of sensitive electronics, and is easily preventable with simple precautions.

Enter the search phrase “ESD Precautions for Handling Electronics” in an internet search engine to find information on ESD-safe handling practices.

We recommend that you always observe ESD precautions when handling the PTCxK-CH controller and load.

## THERMAL MOUNTING CONSIDERATIONS

The chassis-mounted PTCxK-CH temperature controllers are rated to dissipate a significant amount of heat internally, and must be adequately heatsinked in order to prevent overheating the controller. An external heatsink is necessary, and at higher power dissipation a fan will be required to increase airflow over the heatsink.



ENSURE ADEQUATE HEATSINKING AND AIRFLOW ARE PROVIDED IN ORDER TO PREVENT OVERHEATING AND POTENTIALLY DAMAGING THE PTCxK-CH CONTROLLER.

## WIRE THE CONTROLLER

Refer to **Table 3** to determine which configuration applies to your application, and then reference the associated figure for wiring instructions.

Refer to **page 3** for complete information on the pin functions, operating parameters, and transfer functions.

**Table 3. Wiring Configurations**

CONFIGURATION	DIAGRAM
TEC with Negative Temperature Coefficient Sensor	<b>Figure 4</b>
Heater with Negative Temperature Coefficient Sensor	<b>Figure 5</b>
TEC with Positive Temperature Coefficient Sensor (RTD, LM335, AD590)	<b>Figure 6</b>
Heater with Positive Temperature Coefficient Sensor	<b>Figure 7</b>

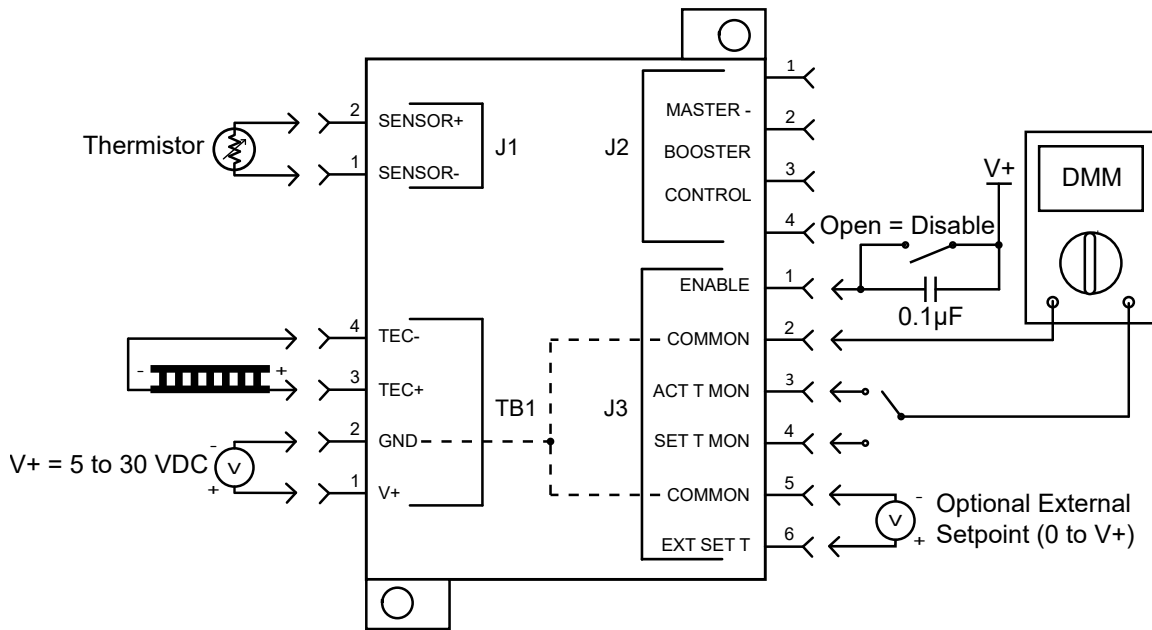

Use caution when the PTC is combined with a PLD laser driver: if the TEC or thermistor is connected to the laser diode, two power supplies may be required and must float independently of each other.

Figure 4. Wiring Diagram for TEC Operating with Negative Temperature Coefficient Sensor

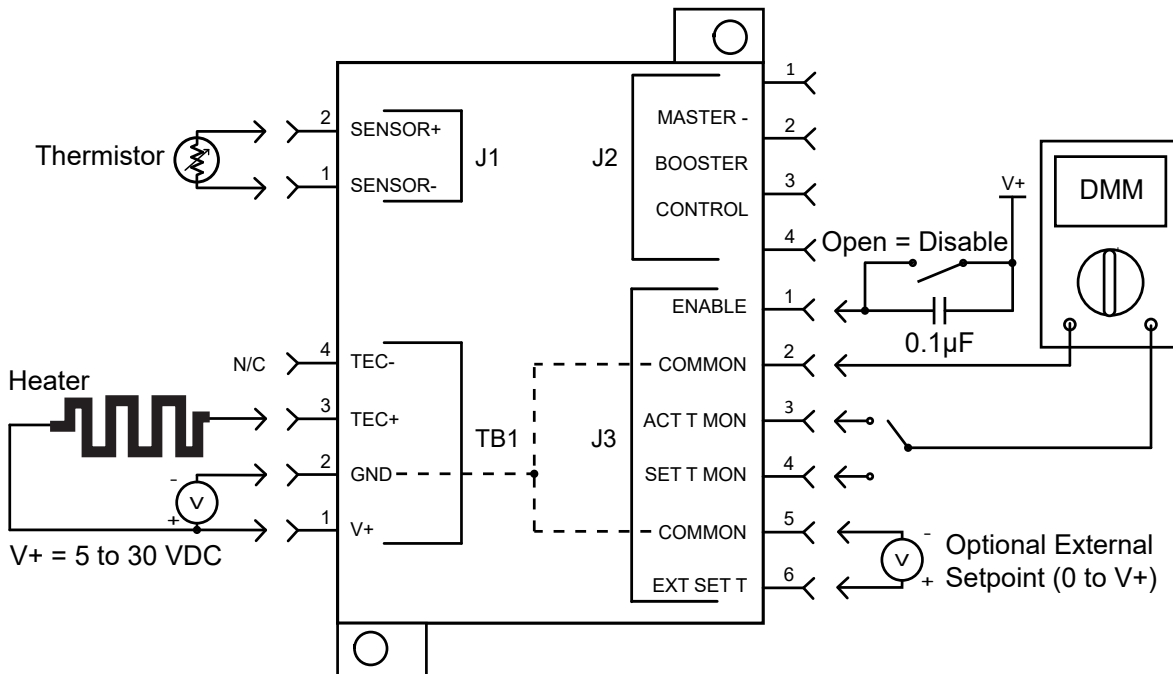

Use caution when the PTC is combined with a PLD laser driver: if the heater or thermistor is connected to the laser diode, two power supplies are required and must float independently of each other.

Figure 5. Wiring Diagram for Heater Operating With Negative Temperature Coefficient Sensor

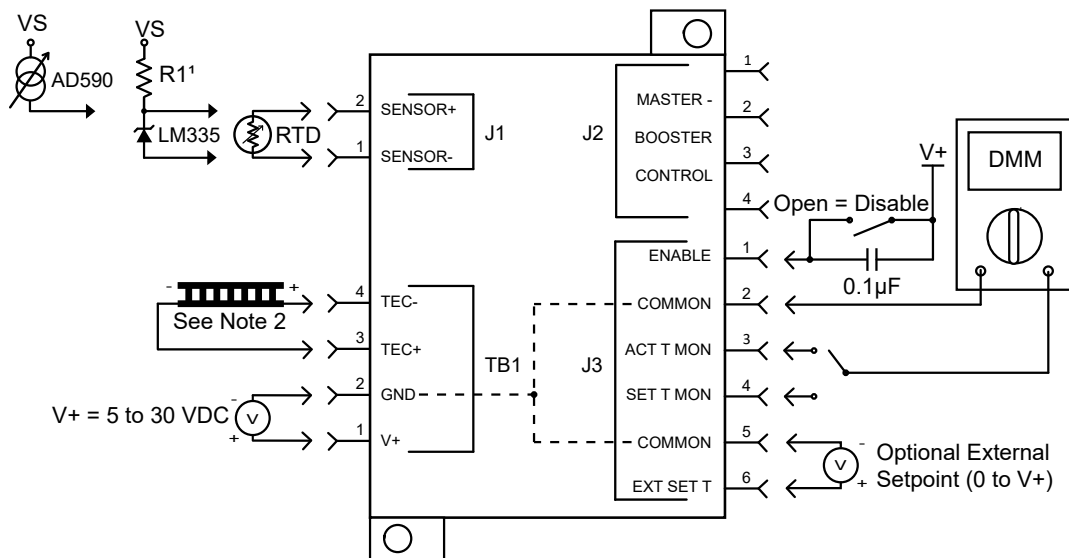

1. Refer to the LM335 datasheet to determine the value of R1.
2. Current flows from TEC+ to TEC-. For PTC sensors, connect the TEC+ lead to pin TB1-4, and the TEC- lead to pin TB1-3.



Use caution when the PTC is combined with a PLD laser driver: if the TEC or thermistor is connected to the laser diode, two power supplies are required and must float independently of each other.

Figure 6. Wiring Diagram for Operating with TEC PTC Sensors (RTD, LM335, AD590)

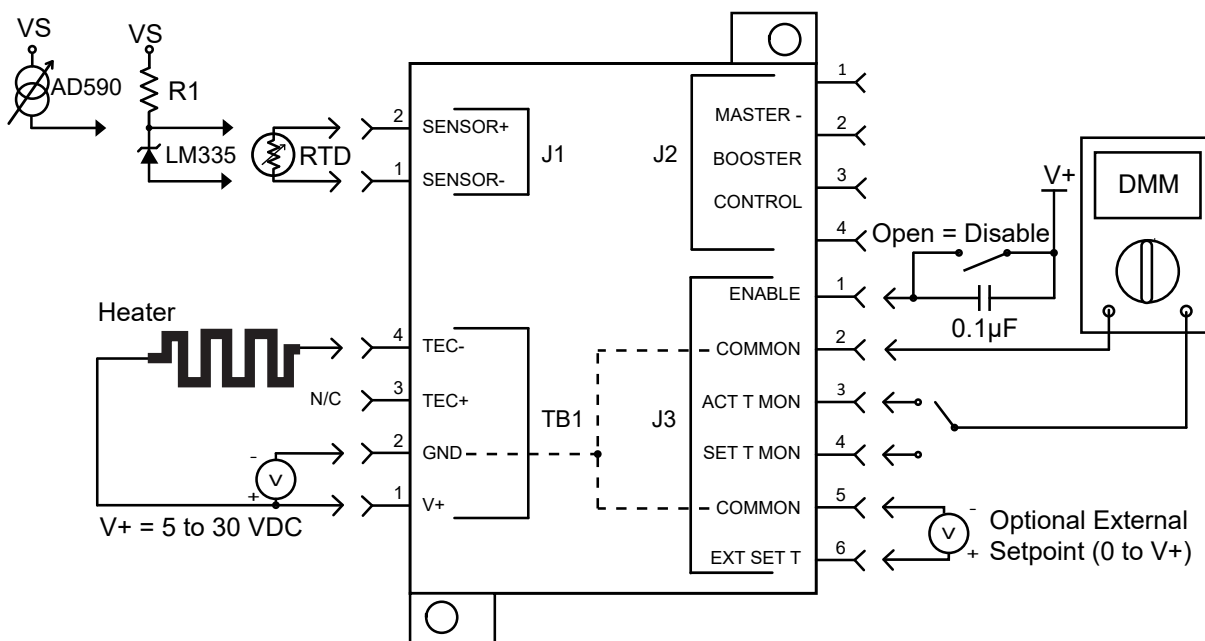

Use caution when the PTC is combined with a PLD laser driver: if the heater or thermistor is connected to the laser diode, two power supplies are required and must float independently of each other.

Figure 7. Wiring Diagram for Heater and Positive Temperature Coefficient Sensor

### INTERNAL ADJUSTMENTS AND CONTROLS

Configuring the controller requires removing the top cover. In an ESD-safe zone, remove the two small Phillips-head screws that secure the cover to the chassis. **Figure 8** illustrates the locations of the controls for product Revision F. For previous revisions, control components may be in different locations

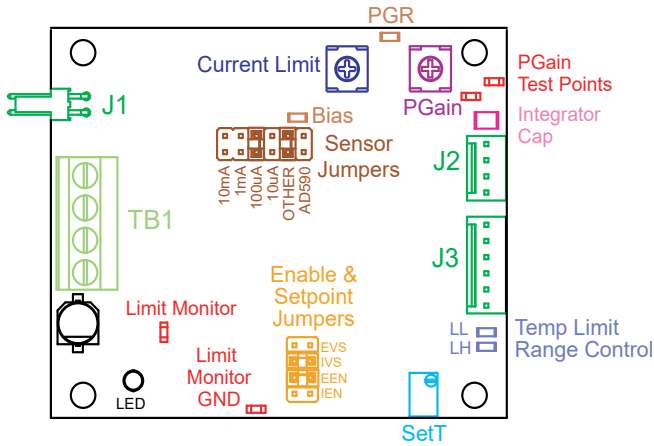
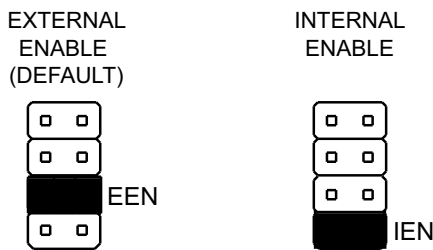

Figure 8. Internal Controls

### SET THE EXTERNAL / INTERNAL ENABLE JUMPER

The output can be enabled either remotely, or internally so that the output is on whenever power is applied to the unit. **Figure 9** illustrates the jumper positions.

- **External Enable.** Set the jumper to the EEN position. This is the factory-default setting.
- **Internal Enable.** Set the jumper to IEN. Output current is enabled whenever power is applied to the controller.



Solid bar indicates jumper location.

Figure 9. External and Internal Enable Jumpers

### SET THE EXTERNAL / INTERNAL VOLTAGE SETPOINT JUMPER

The temperature setpoint is controlled by a 12-turn onboard trimpot, or by an external signal. **Figure 10** illustrates the jumper positions.

- **Internal Setpoint.** Set the jumper to IVS. This is the factory-default setting.
- **External Setpoint.** Set the jumper to EVS.

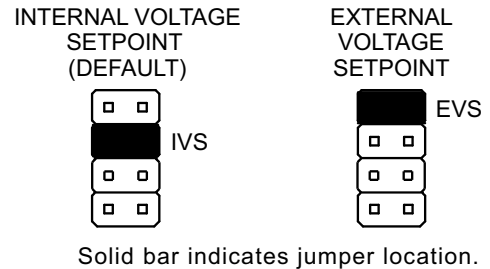

Solid bar indicates jumper location.

Figure 10. External and Internal Setpoint Jumpers

### SET THE SENSOR BIAS CURRENT

**Figure 11** shows the bias current jumper positions. **Table 4** explains how to set the jumpers for the various sensors.

The resistance of the sensor over the application temperature range, in conjunction with the sensor bias current, must produce a voltage between 0.25 and 5 V. To calculate the voltage drop across the sensor use **Equation 1**:

**Equation 1. Voltage Drop Across Sensor**

$$V_{\text{SENSOR}} = R_{\text{SENSOR}} * I_{\text{BIAS}}$$

Select the bias current according to the equation above so that the sensor voltage does not exceed 5 V.

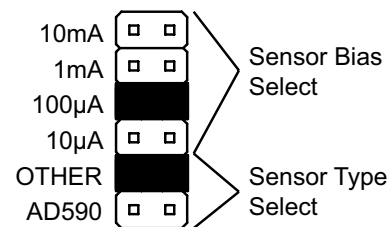

Solid bar indicates jumper location.

Figure 11. Sensor Bias Jumpers

Table 4. Sensor Bias Jumper Settings

SENSOR	10mA	1mA	100µA	10µA	OTHER	AD590
Thermistor			X or X	X		
100 Ω RTD	X				X	
LM335		X			X	
AD590						X

## SET THE OUTPUT CURRENT LIMIT

Determine the maximum operating current of your TE module ( $I_{LIM}$ ). Limit Monitor Voltage is given by **Equation 2**:

**Equation 2. Limit Monitor Voltage**

$$LIM\ MON\ V = I_{LIM} * Transfer\ Function$$

**Table 5. Monitor Transfer Function**

PTC2.5K-CH	PTC5K-CH	PTC10K-CH
0.4 V/A	0.2 V/A	0.1 V/A

NOTE: The Limit Monitor is not available on Revisions A, B, or C.

Connect the DMM positive lead to the Limit Monitor test point using “mini-grabber” clip-on test leads. Connect the negative lead to the Limit Monitor GND test point shown in **Figure 12**. NOTE: Test points may be in different locations if using a product before Revision F.

Switch on the power supply to the PTCxK-CH.

Turn the Current Limit trimpot until the  $V_{LIMIT}$  value calculated above is displayed on the DMM. Switch off the power supply.

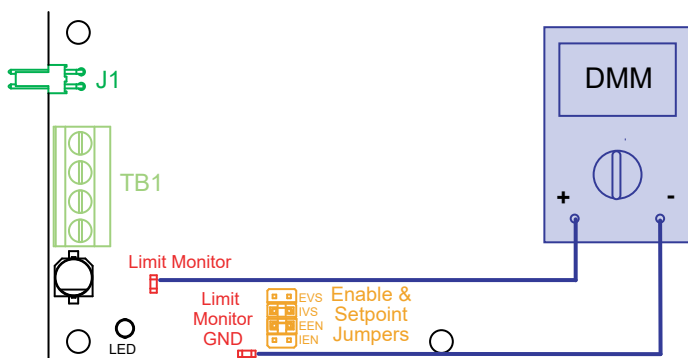

**Figure 12. Monitor Test Points**

You can also use the tic marks on the  $I_{LIM}$  trimpot to roughly set the current limit. **Figure 13** illustrates the trimpot tic marks and the default current limit setting (jn red).

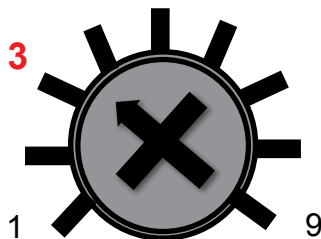

**Figure 13. Current Limit Trimpot**

The row highlighted in cyan in **Table 6** indicates the default current limits. NOTE: If the controller is compliance limited, it will not reach the current listed in the table.

**Table 6. Trimpot Settings**

TIC MARK	PTC2.5K-CH	PTC5K-CH	PTC10K-CH
1	0 A	0 A	0 A
2	0.20 A	0.47 A	0.96 A
3	0.50 A	1.11 A	2.3 A
4	0.876 A	1.84 A	3.36 A
5	1.17 A	2.45 A	4.37 A
6	1.63 A	3.16 A	5.79 A
7	2.0 A	3.84 A	7.37 A
8	2.2 A	4.5 A	8.73 A
9	2.5 A	5.0 A	10 A

## SET THE CURRENT LIMIT—REVISIONS A, B, & C

On product revisions C and earlier, the current limit was set by an indicator on a rotary potentiometer. **Table 7** explains the current limit settings.

The product revision is the third character of the serial number that is stamped or labeled on each unit.

**Table 7. Early Revision Current Limit Settings**

POT POS.	CURRENT LIMIT VALUE IN AMPS		
	PTC2.5K-CH	PTC5K-CH	PTC10K-CH
1	In this range, the response is non-linear.		
2			
3			
4	1	2	4
5	1.25	2.5	5
6	1.5	3	6
7	1.75	3.5	7
8	2	4	8
9	2.25	4.5	9
10	2.5	5	10

## ADJUST THE TEMPERATURE SETPOINT

The temperature is controlled by a signal equal to the voltage drop across the sensor at the desired temperature setpoint. Calculate the temperature setpoint voltage as follows:

- Refer to the resistance vs. temperature table for your thermistor or RTD to find the resistance at the desired temperature. If you are using an AD590 or LM335, refer to the datasheet for the temperature transfer function.
- Calculate the sensor voltage drop at the setpoint temperature using **Equation 3**:

**Equation 3. Sensor Voltage Drop at Setpoint**

$$V_{\text{SETPOINT}} = I_{\text{BIAS}} * R_{\text{SENSOR}}$$

Connect the multimeter positive lead to SET T MON (pin J3-4) and the negative lead to COMMON (pin J3-2).

**Internal Voltage Setpoint (IVS).** If the jumper is set to Internal Setpoint control, adjust the SET T trimpot until the voltage displayed on the DMM matches the  $V_{\text{SETPOINT}}$  value calculated above.

**External Voltage Setpoint (EVS).** If the jumper is set to External Setpoint control, adjust the voltage input to EXT SET T (pin J3-6) until the voltage displayed on the DMM matches the  $V_{\text{SETPOINT}}$  value calculated above.

If the external setpoint voltage is lost or drops below 0.3 V, the controller triggers a safety circuit and defaults the internal setpoint to 1 V. Using a 10 k $\Omega$  thermistor, the 1 V setpoint is equal to 25°C. The default safe voltage can be changed at the factory; call for information.

## ENABLE THE OUTPUT

If the output of the PTCxK-CH is configured to use the external enable signal, apply a TTL-HI signal to ENABLE (pin J3-1) to enable the output. To disable the output, apply a TTL-LO signal.

If the PTCxK-CH is configured to use the internal enable function, then the output is enabled whenever power is applied to the controller.

## COMPLETE THE CONFIGURATION

Switch off the power supply. Then replace the cover on the module and tighten the two screws.

Remove the thermistor and load test circuits and wire in the actual temperature sensor and TEC or resistive heater. Refer to the appropriate wiring diagram (**Figure 4** through **Figure 7**).

## MONITOR THE ACTUAL TEMPERATURE

The actual sensor voltage can be monitored using a DMM connected across ACT T MON and COMMON (pins J3-3 and J3-2). Refer to **Table 2** for the transfer function.

The sensor setpoint can be monitored using a DMM connected across SET T MON and COMMON (pins J3-4 and J3-2). Refer to **Table 2** for the transfer function.

# SETTINGS AND ADJUSTMENTS

## PROPORTIONAL GAIN

NOTE: The P & I default settings perform well for a wide range of load configurations, so adjusting the  $P_{GAIN}$  may not be necessary.

Turning the  $\frac{3}{4}$ -turn trimpot (shown in **Figure 14**) clockwise will increase the gain and can be adjusted to improve the time-to-temperature and stability. The  $P_{GAIN}$  range is 5-40 A/V and the default setting is 14 A/V. Normally we recommend driving the load to overshoot the setpoint by about 10% to quickly reach temperature. Too high of a gain may result in oscillations around the setpoint.

NOTE: Adjusting the Current Limit 5% below the steady state control current will improve stability. Application permitting, adjust the setpoint temperature above or below ambient temperature by 3-5°C. This will increase the steady state current level and will be less likely to switch between the Heat/Cool currents causing oscillations. This will also help with fast ambient temperature disturbances.

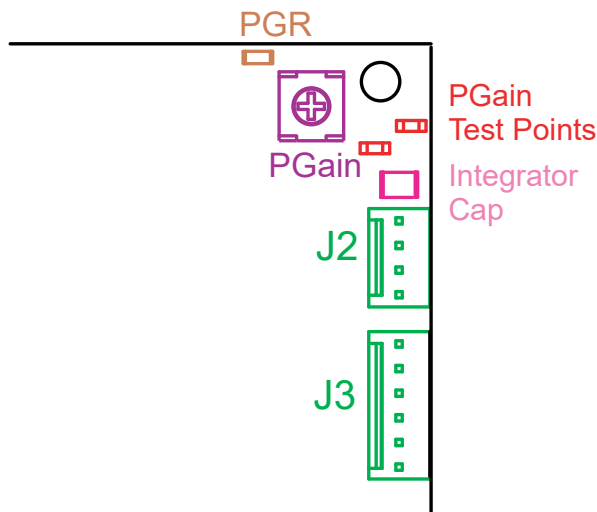

Figure 14. Proportional Gain & Test Point Locations

## MEASURE THE $P_{GAIN}$ VALUE

**Figure 14** shows the location of two onboard test points that allow you to measure the resistance of the  $P_{GAIN}$  trimpot. The test points can be accessed with the cover in place.

Use quick connect test leads to connect the DMM to the two test points. Wait 30 seconds for the Integrator capacitor to discharge, then record the resistance reading. The resistance range is 30 kΩ to 230 kΩ.

The value of  $P_{GAIN}$  can be calculated using **Equation 4** and the values in **Table 8**.

### Equation 4. $P_{GAIN}$ Calculation

$$P_{GAIN} = \left( \frac{R_{PGAIN}}{R} \right) \times G$$

Table 8. Calculating  $P_{GAIN}$

MODEL	DEFAULT $P_{GAIN}$ RESISTANCE	DEFAULT GAIN	R	G
PTC2.5K-CH	80 kΩ	14	7000	1.22
PTC5K-CH	80 kΩ	14	14000	2.44
PTC10K-CH	80 kΩ	14	29000	5.05

When adjusting the  $P_{GAIN}$  trimpot, allow sufficient time for the resistance value to settle.

## INTEGRATOR TIME CONSTANT

The Integrator Time Constant is set with a fixed component value. The default values and recommended settings are shown in **Table 9**.

Table 9. Integrator Time Constants

MODEL	DEFAULT TIME CONSTANT
PTC2.5K-CH	1.5 μF
PTC5K-CH	3.3 μF
PTC10K-CH	5.6 μF

The  $I_{TERM}$  sets the Integrator Time Constant of the system from 0 to 10 seconds. Use a capacitor with a dissipation factor less than 1% for the best performance. Metalized film polyester, polypropylene or ceramic. Loads with larger thermal delays require longer time constants up to 10 seconds. The Panasonic Series (1210 size) can be used (P/N ECJ-4YB1E).

**Table 10** indicates Integrator Time Constant settings appropriate for various sensor and load response combinations.

Table 10. Time Constants for Sensor/Load Combinations

SENSOR / LOAD TYPE	INTEGRATOR TIME CONSTANT (CAPACITANCE)
Thermistor / Fast	<1.5 μF
Thermistor / Medium	1.5 μF - 5.6 μF
Thermistor / Slow	5.6 μF - 10 μF
RTD / Fast	<0.5 μF
RTD / Slow	0.5 μF - 1.5 μF

### EXT SET T SAFETY VOLTAGE MODIFICATION

Figure 15 shows the divider string circuit for setting up the EXT SET T safety voltage trip point. The default voltage is 0.156 V, then it gets multiplied by 2 down circuit, setting up the actual default voltage of 0.312 V. The size of the resistors are 1206, so the resistor can be changed in the field.

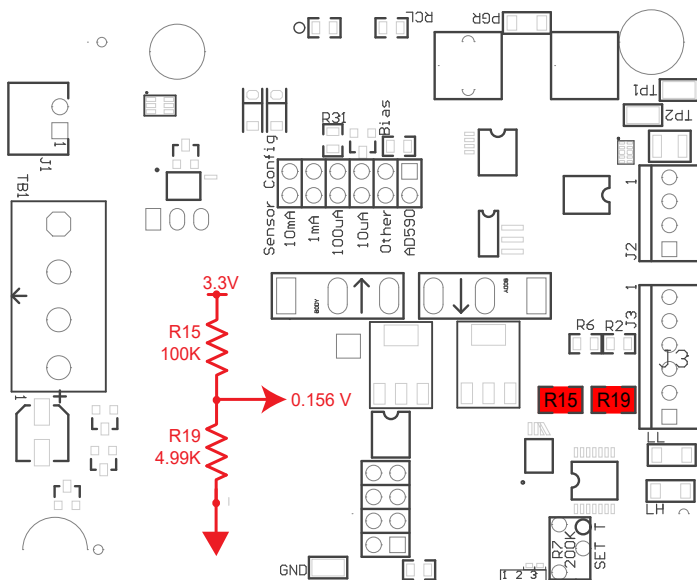

Figure 15. EXT SET T Example Circuit (Rev. F)

To change the trip point voltage, change the value of  $R_{19}$  as determined by Equation 5.

#### Equation 5. Trip Point Voltage

$$R_{19} = \frac{V_{\text{TRIP POINT}} * 100,000}{6.6 - V_{\text{TRIP POINT}}} \quad [\Omega]$$

### SAFETY DEFAULT VOLTAGE MODIFICATION

Figure 16 shows the divider string circuit for the safety default setpoint temperature voltage. When the EXT SET T voltage drops below 0.539 V, the system switches this voltage in as the setpoint -- protecting the temperature of your load. The default voltage is 0.539 V and it is multiplied by 2 down circuit, providing a setpoint voltage of 1.079 V. When using a 10 kΩ thermistor, it equals 25°C, with 55 μA current through the resistors. These resistors are 1206 SMTs and they can be changed in the field.

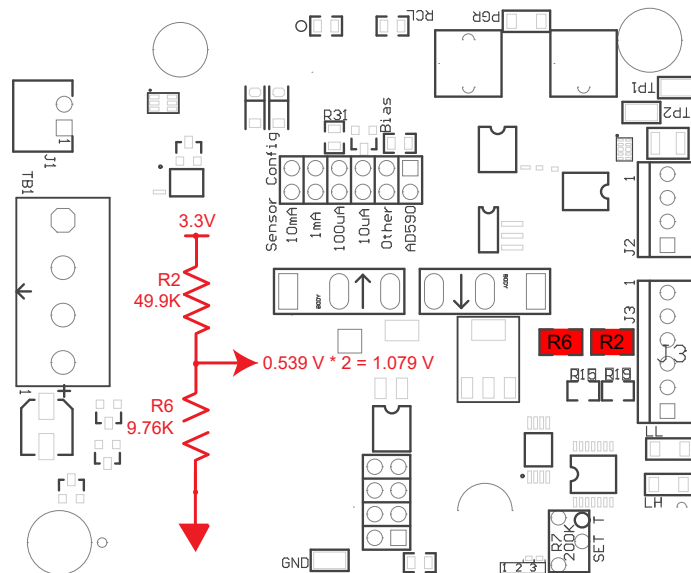

Figure 16. Safety Default Example Circuit (Rev. F)

To change the default setpoint voltage, change the value of  $R_6$  as determined by Equation 6.

#### Equation 6. Default Setpoint Voltage

$$R_6 = \frac{V_{\text{SETPOINT}} * 49,900}{6.6 - V_{\text{SETPOINT}}} \quad [\Omega]$$

## ADDITIONAL TECH NOTES

This section includes useful technical information on these topics:

- **Cable Length and Electronic Noise**
- **Product Variations**
- **Master / Booster Operation**
- **Safe Operating Area Calculation**

### CABLE LENGTH AND ELECTRONIC NOISE

Keep all cable runs as short as possible, and particularly the high current cables. Longer leads will result in larger voltage drop, wire heating, and increased susceptibility to radiated electrical noise.

Use twisted wire pairs in order to minimize susceptibility to electrical noise and to optimize performance.

### PRODUCT VARIATIONS

We design and manufacture our products in-house, and that gives us the unique ability to modify our drivers and controllers to suit exactly your application. Our Product Variation service allows us to quickly and cost-effectively address your design requests, from prototype quantities to long-term high-volume manufacturing.

Examples of Product Variations include:

- Replacing current limit and temperature setpoint trim pots with fixed-value resistors to maximize long-term stability in OEM controller systems.
- Modifying the  $P_{GAIN}$  range to suit the characteristics of your particular thermal load.
- Implementing the ability to remotely set the output current limit.
- Limiting the setpoint range with fixed resistors.
- Changing the default safe-temperature for DAQ protection circuit.

### MASTER / BOOSTER OPERATION

Using the WCB501 cable, the PTC10K-CH can be tied to the specially-designed PTC10K-BOOST “booster” unit to double the maximum output current to ±20 A. Refer to **Figure 17** for the basic wiring diagram.

When you are using the PTCxK-CH in a master / booster application, the control settings apply only to the master unit, and the temperature setpoint is controlled only from the master unit.

To identify a “booster” unit, look at the serial number engraved below PTC10K-CH on the unit. A booster unit will always have a serial number that begins with “BOOSTER” for product revisions G and later.

Additionally, the PTC10K-BOOST booster units do NOT have the following parts installed:

- J1 connector (includes Sensor+ and Sensor-)
- J3 connector (includes Enable, Common, Act T Mon, Set T Mon, Common, Ext T Set)
- Output Enabled LED
- Temp Set Trimpot
- PGAIN Trimpot

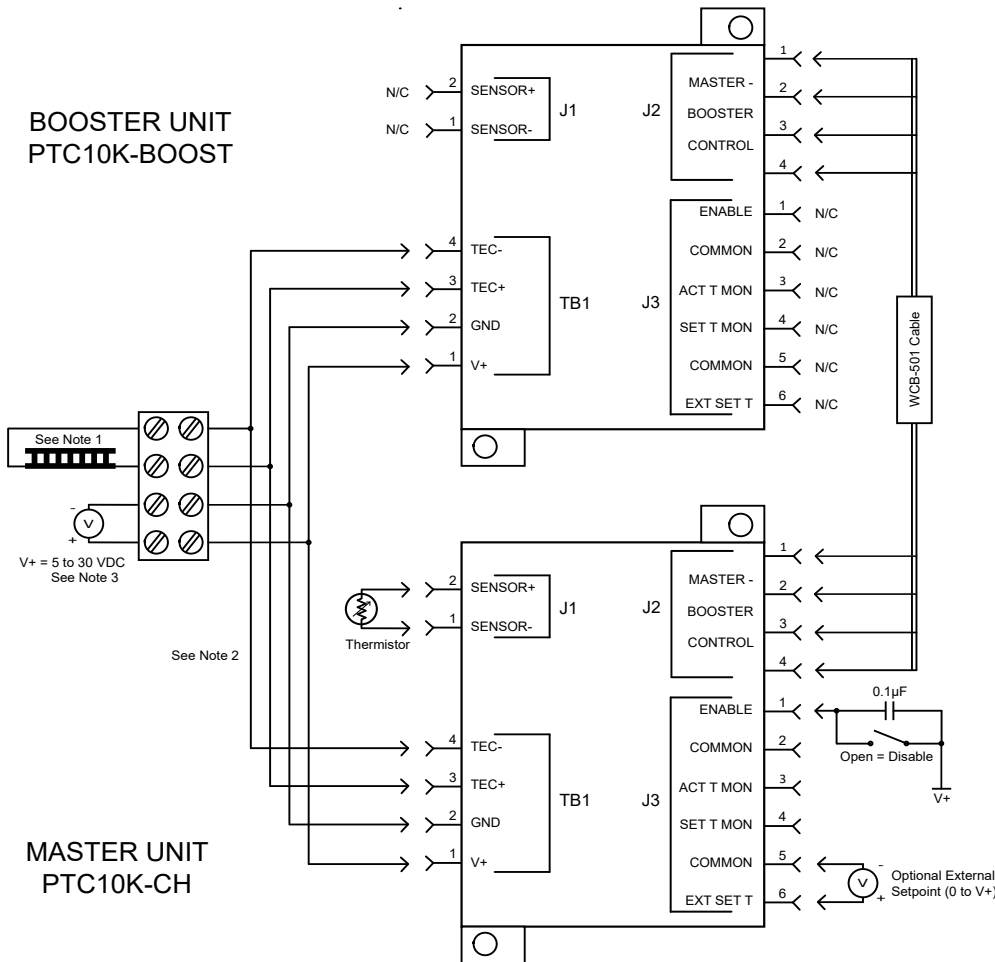

1. Connect the TEC+ lead to pin TB1-3, connect the TEC- lead to pin TB1-4 (direction of current flow depends on the type of sensor used).
2. Keep the power and TEC leads as short as possible, and use twisted pairs of suitable gauge.
3. Use caution when the PTC is combined with a PLD laser driver: if the TEC or thermistor is connected to the laser diode, two power supplies are required and must float independently of each other.

**Figure 17. Master / Booster Wiring Diagram**

The master / booster configuration can be used with all combinations of temperature sensors and TEC or heater, as described in **Figure 4** through **Figure 7**.

**NOTE:** To double the output current, the configuration requires a master (PTC10K-CH) unit and a booster (PTC10K-BOOST) unit. The master unit cannot be used

### SAFE OPERATING AREA CALCULATION

The Safe Operating Area of the PTCxK-CH is determined by the amount of power that can be dissipated within the output stage of the controller. If that power limit is exceeded permanent damage can result.

Refer to the Wavelength Electronics website for the most up-to-date SOA calculator for our products. The online tool is fast and easy to use, and also takes into consideration ambient operating temperature.

[www.teamwavelength.com/support/design-tools/soa-to-calculator/](http://www.teamwavelength.com/support/design-tools/soa-to-calculator/)



DO NOT OPERATE THE UNIT OUTSIDE THE SAFE OPERATING AREA CURVE.

OPERATING THE PTCXK-CH OUTSIDE OF THE SOA VOIDS THE WARRANTY.

Follow these steps to determine if the PTCxK-CH will be operating within the SOA:

- Refer to the TEC datasheet to find the maximum voltage ( $V_{MAX}$ ) and current ( $I_{MAX}$ ) specifications
- Calculate the voltage drop across the controller:

**Equation 1.** 
$$V_{DROD} = V+ - V_{MAX}$$

- Mark  $V_{DROD}$  on the X-axis, and extend a line upward
- Mark  $I_{MAX}$  on the Y-axis, and extend a line to the right until it intersects the  $V_{DROD}$  line
- On the X-axis, mark the supply voltage ( $V+$ )
- Extend a diagonal line from  $V+$  to the intersection of the  $V_{DROD}$  and  $I_{MAX}$  lines; this is the Load Line
- If the Load Line crosses the Safe Operating Area line at any point, the configuration is not safe

If the SOA calculator indicates the PTCxK-CH will be outside of the Safe Operating Area, the system must be changed so that less power is dissipated within the driver. See application note [AN-LDTC01 : The Principle of the Safe Operating Area](#) for information on shifting the Load Line.

After changing any of the parameters, recalculate the SOA to make sure the controller will operate safely. If you have questions, or run into difficulties calculating the SOA, contact Wavelength Electronics for assistance.

Blank charts are provided on the following page for you to calculate the SOA of your application.

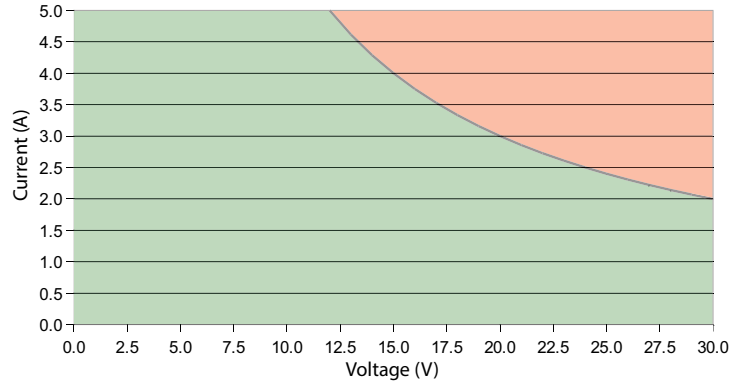

Figure 18. PTC2.5K-CH SOA Calculation Chart

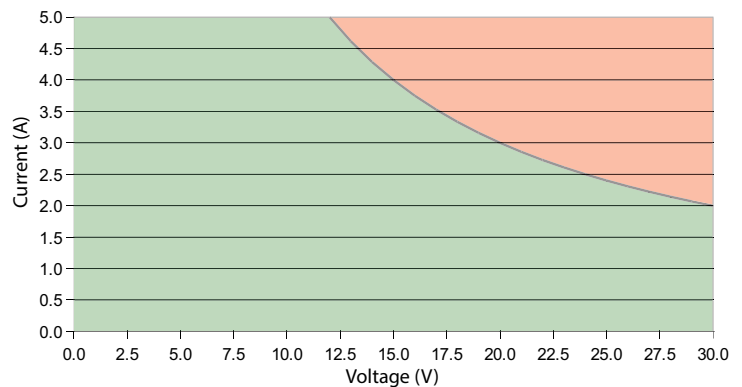

Figure 19. PTC5K-CH SOA Calculation Chart

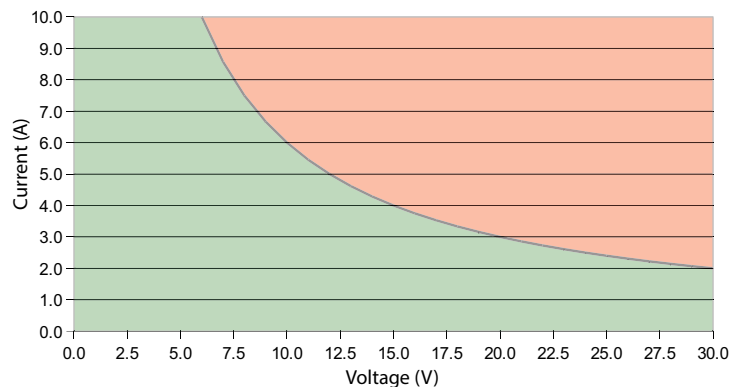

Figure 20. PTC10K-CH SOA Calculation Chart

as a booster.

## TROUBLESHOOTING

PROBLEM	POTENTIAL CAUSES	SOLUTIONS
Output will not enable –OR– Output will not disable	Improperly configured jumpers on the PTCxK-CH unit  Remote Enable signal is not correct	Make sure that the External Enable / Internal Enable (EEN / IEN) jumper is set correctly for your application.  If you are using the External Enable function, make sure that the enable signal is properly configured. Either use a switch as shown in the wiring diagrams, or use a TTL-compatible signal where Disable = LO (<1.45 V). Enable = HI (>3.4 V).
Temperature is decreasing when it should be increasing –OR– Temperature is increasing when it should be decreasing	The TEC may be connected backwards to the PTCxK-CH	The convention is that the <b>red</b> wire on the TEC module connects to TEC+ (pin TB1-3) and the <b>black</b> wire to TEC- (pin TB1-4). If your TEC is connected in this manner and the problem persists, the TEC module itself may be wired in reverse. Switch off power to the system, reverse the connections to the PTCxK-CH, and then try again to operate the system.  TEC wiring polarity is dependent on temperature sensor type (NTC vs. PTC). Verify that the polarity is correct for the sensor type you are using.
Temperature increases beyond the setpoint and will not come down	The heatsink may be inadequately sized to dissipate the heat from the load and TEC module, and now the system is in a condition called <b>thermal runaway</b>	<ul style="list-style-type: none"> <li>• Increase the size of the heatsink, add a fan to blow air over the heatsink, and/or reduce the ambient air temperature around the heatsink.</li> <li>• Apply a thin layer of thermal paste or use thermal washers between the load, the TEC surfaces, and the heatsink.</li> </ul>
	The TEC and heatsink are not adequately sized for the thermal load	The heat being generated by the load may be too great for the TEC to pump to the heatsink; a larger TEC may be needed. Consult technical note <i>TN-TC01: Optimizing Thermoelectric Temperature Control Systems</i> at <a href="https://www.teamwavelength.com/download/applicationtechnotes/tn-tc01.pdf">https://www.teamwavelength.com/download/applicationtechnotes/tn-tc01.pdf</a>
Temperature does not stabilize very well at the setpoint	Poor thermal contact between components of the thermal load	Use thermal paste or washers between the load/TEC and TEC/heatsink interfaces. Make sure the temperature sensor is in good thermal contact with the load.
	Operating outside of the ideal region of the temperature sensor	The sensor type and bias current should be selected to maximize sensitivity at the target temperature. Thermistors provide the best performance, particularly for applications where a single setpoint temperature must be accurately maintained. For example, at 25°C a 10 kΩ thermistor has a sensitivity of 43 mV/°C, whereas an RTD sensor has a sensitivity of 4 mV/°C.
	Proportional control term is set too high	Reduce the value of the proportional term. For more information reference Wavelength's technical note <i>TN-TC01: Optimizing Thermoelectric Temperature Control Systems</i> at <a href="https://www.teamwavelength.com/download/applicationtechnotes/tn-tc01.pdf">https://www.teamwavelength.com/download/applicationtechnotes/tn-tc01.pdf</a>
Temperature is slow to stabilize and is not within the specifications	Setpoint temperature is set close to the ambient temperature	Set the temperature at least 10°C above ambient when using a resistive heater. A resistive heater is unable to precisely maintain temperatures near ambient because once the temperature overshoots the setpoint, the controller turns off and relies on ambient temperature to cool the load. If setting the temperature 10°C or more above ambient is not possible, then choose a thermoelectric controller, which can alternately heat and cool the load to maintain a more precise setpoint temperature.

PROBLEM	POTENTIAL CAUSES	SOLUTIONS
Temperature does not reach the setpoint	Insufficient current driven to the TEC or heater	Increase the current limit - but DO NOT exceed the specifications of the TEC or heater.
	The controller does not have sufficient compliance voltage to drive the TEC or heater	Increase the power supply voltage. Be certain to verify that the controller is within the Safe Operating Area: <a href="https://www.teamwavelength.com/support/design-tools/soa-tc-calculator/">https://www.teamwavelength.com/support/design-tools/soa-tc-calculator/</a>
PTC does not respond to remote temperature setpoint input	The External / Internal Voltage Setpoint jumper is improperly configured	To configure the PTCxK-CH to reference the setpoint signal on EXT SET T and COMMON (pins J3-6 and J3-5), set the jumper to EVS.
	The EXT SET T signal is below the minimum signal value of 0.3 V	If the EXT SET T signal falls below 0.3 V, the PTCxK-CH defaults to a "safe temperature" setpoint voltage of 1 V. The actual safe temperature depends on the sensor and bias current configuration. For a 10 kΩ thermistor at 100 μA bias current, the default temperature setpoint is 25°C. The safe temperature setpoint voltage can be changed at the factory if your application requires it. To reset the safety circuit, the EXT SET T signal must be greater than 0.4 V.

# CABLE SPECIFICATIONS

## WCB107 POWER/TEC CABLE; ORDER SEPARATELY

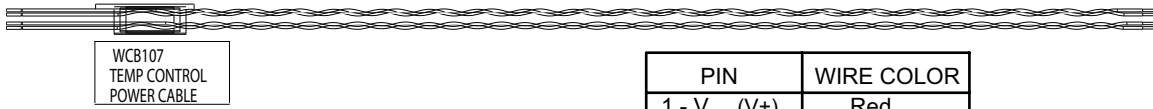

- 24" Long, 14 AWG
- Strain relieve the cable within 1" of the terminal block to avoid stress on the cable.
  - Keep power cable as short as possible to minimize voltage drop at high current.

PIN	WIRE COLOR
1 - $V_{DD}$ (V+)	Red
2 - GND	Black
3 - TEC+	Orange
4 - TEC-	Yellow

## WCB106 INPUT/OUTPUT CABLE; INCLUDED WITH PTCXK-CH

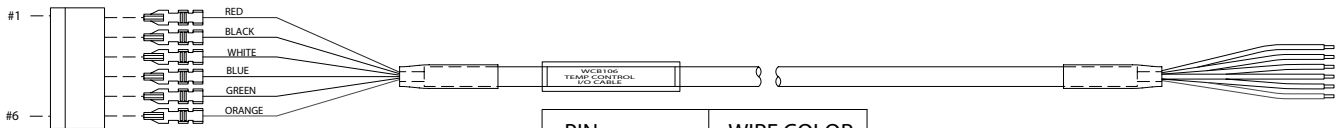

Molex KK 7880 Series Connector  
36" Long, 22 AWG

PIN	WIRE COLOR
1 - ENABLE	Red
2 - COMMON	Black
3 - ActT MON	White
4 - SetT MON	Blue
5 - COMMON	Green
6 - ExtSET	Orange

## WCB105 SENSOR CABLE; INCLUDED WITH PTCXK-CH

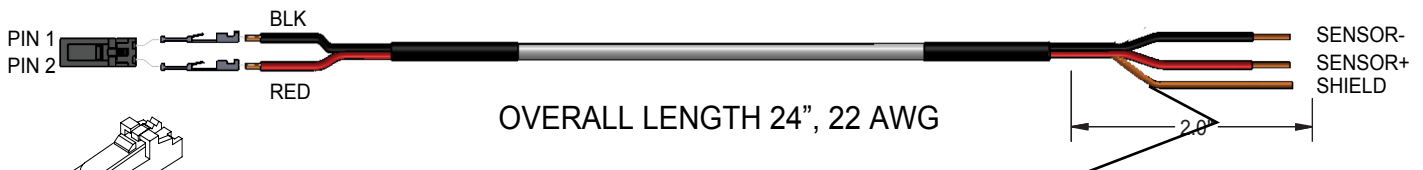

MOLEX #50-57-9402  
Crimp Pins: 16-02-1115

PIN	WIRE COLOR
1 - SENSOR-	Black
2 - SENSOR+	Red

## WCB501 MASTER/BOOSTER CABLE; INCLUDED WITH PTC10K-BOOST

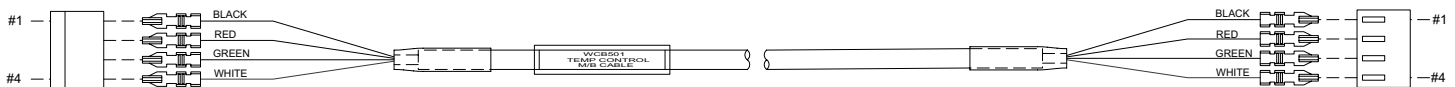

Molex KK 7880 Series Connector  
12" Long, 22 AWG

Ends are Interchangeable

All dimensions are inches [mm]. All tolerances are ±5%.

# MECHANICAL SPECIFICATIONS

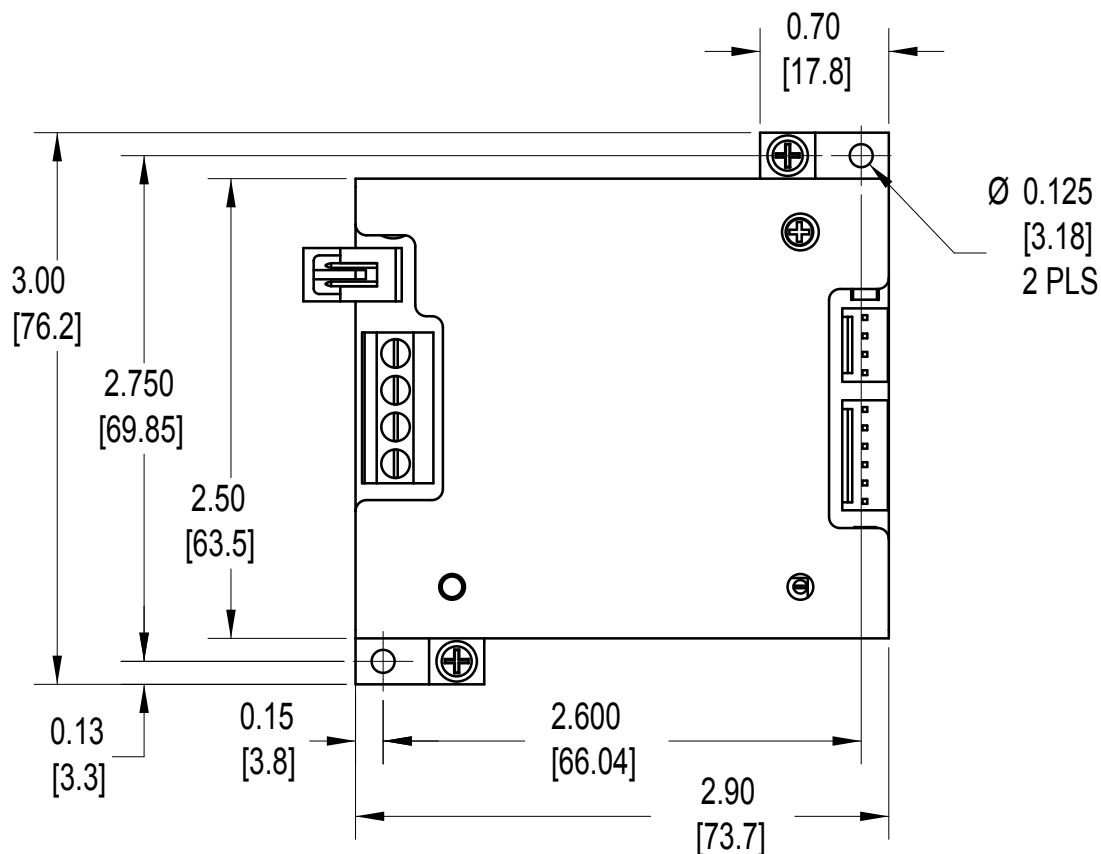

Recommended Airflow Direction →

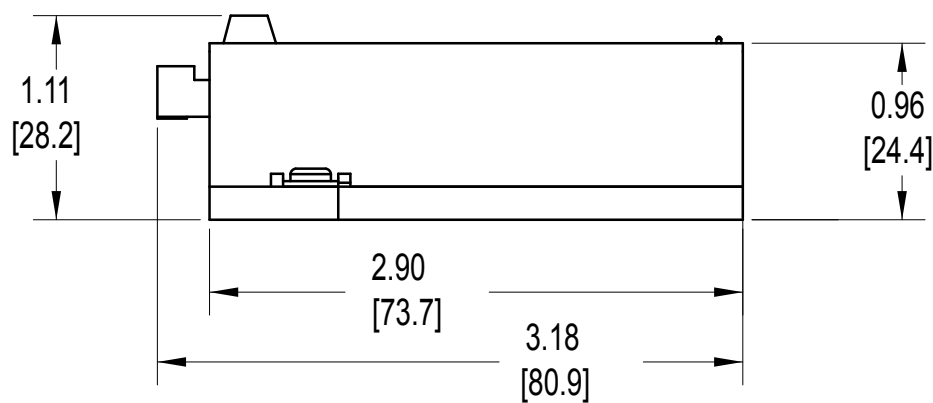

Dimensions in [mm] inches; Tolerance ±5%

# CERTIFICATION AND WARRANTY

## CERTIFICATION

Wavelength Electronics, Inc. (Wavelength) certifies that this product met its published specifications at the time of shipment. Wavelength further certifies that its calibration measurements are traceable to the United States National Institute of Standards and Technology, to the extent allowed by that organization’s calibration facilities, and to the calibration facilities of other International Standards Organization members.

## WARRANTY

This Wavelength product is warranted against defects in materials and workmanship for a period of one (1) year from date of shipment. During the warranty period, Wavelength will, at its option, either repair or replace products which prove to be defective.

## WARRANTY SERVICE

For warranty service or repair, this product must be returned to the factory. An RMA is required for products returned to Wavelength for warranty service. The Buyer shall prepay shipping charges to Wavelength and Wavelength shall pay shipping charges to return the product to the Buyer upon determination of defective materials or workmanship. However, the Buyer shall pay all shipping charges, duties, and taxes for products returned to Wavelength from another country.

## LIMITATIONS OF WARRANTY

The warranty shall not apply to defects resulting from improper use or misuse of the product or operation outside published specifications. No other warranty is expressed or implied. Wavelength specifically disclaims the implied warranties of merchantability and fitness for a particular purpose.

## EXCLUSIVE REMEDIES

The remedies provided herein are the Buyer’s sole and exclusive remedies. Wavelength shall not be liable for any direct, indirect, special, incidental, or consequential damages, whether based on contract, tort, or any other legal theory.

## REVERSE ENGINEERING PROHIBITED

Buyer, End-User, or Third-Party Reseller are expressly prohibited from reverse engineering, decompiling, or disassembling this product.

## NOTICE

The information contained in this document is subject to change without notice. Wavelength will not be liable for errors contained herein or for incidental or consequential damages in connection with the furnishing, performance, or use of this material. No part of this document may be translated to another language without the prior written consent of Wavelength.

## SAFETY

There are no user-serviceable parts inside this product. Return the product to Wavelength Electronics for service and repair to ensure that safety features are maintained.

## LIFE SUPPORT POLICY

This important safety information applies to all Wavelength electrical and electronic products and accessories:

As a general policy, Wavelength Electronics, Inc. does not recommend the use of any of its products in life support applications where the failure or malfunction of the Wavelength product can be reasonably expected to cause failure of the life support device or to significantly affect its safety or effectiveness. Wavelength will not knowingly sell its products for use in such applications unless it receives written assurances satisfactory to Wavelength that the risks of injury or damage have been minimized, the customer assumes all such risks, and there is no product liability for Wavelength. Examples of devices considered to be life support devices are neonatal oxygen analyzers, nerve stimulators (for any use), auto-transfusion devices, blood pumps, defibrillators, arrhythmia detectors and alarms, pacemakers, hemodialysis systems, peritoneal dialysis systems, ventilators of all types, and infusion pumps as well as other devices designated as “critical” by the FDA. The above are representative examples only and are not intended to be conclusive or exclusive of any other life support device.

## REVISION HISTORY

DOCUMENT NUMBER: PTC10K-CH400

REV.	DATE	CHANGE
I	July 2016	Updated PGAIN settings information
J	May 2017	Updated Master/Booster information
K	May 2023	Updated Figures 8, 12, 15, and 16 to match new component locations
L	Mar 2024	Updated PTC10K-SL part number to PTC10K-BOOST



# WAVELENGTH ELECTRONICS

51 Evergreen Drive  
Bozeman, Montana 59771

406-587-4910 (tel)  
406-587-4911 (fax)



Sales & Tech Support  
[sales@teamwavelength.com](mailto:sales@teamwavelength.com)  
[techsupport@teamwavelength.com](mailto:techsupport@teamwavelength.com)