

# DATASHEET AND OPERATING GUIDE

## PLDxK-CH Series

### Chassis Mount Laser Diode Drivers

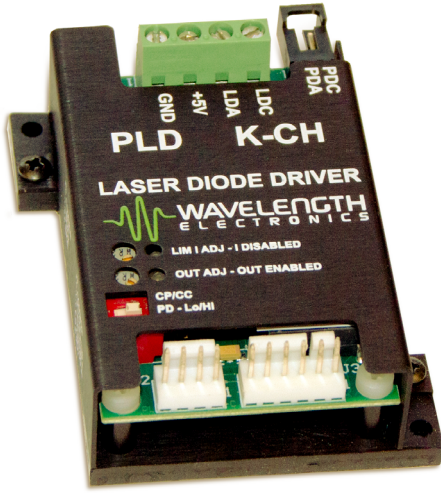

## FEATURES AND BENEFITS

- Models: 5 A, 10 A, 12.5 A
- 5 A and 10 A models operate from a single 5 VDC supply; 12.5 A model requires two supplies
- Separate power supply can be used to drive high-compliance lasers up to 28 V
- Product Variation allows high-compliance up to 85 V.
- Constant Current or Constant Power modes
- Safety features protect your laser
  - » Adjustable latching current limit
  - » Slow-start circuitry
- Local and Remote Enable controls

## RELIABILITY YOU CAN TRUST

The PLDxK-CH Series Laser Diode Drivers deliver the reliability and performance you expect from a Wavelength Electronics laser driver in a compact and easy-to-integrate package.

## APPLICATIONS

Tens of thousands of PLD drivers are deployed in particle counters, manufacturing vision systems, wavefront scanners, fiber aligners, and other laser systems, proving beyond doubt the reliability and stability of the design.

## DESIGNED FOR EASY INTEGRATION

The PLDxK-CH drivers operate from a single 5 V power supply. To accommodate high compliance lasers, or multiple stacked lasers, the PLDxK-CH laser diode drivers allow the laser to be driven from a separate power supply up to 30 V.

## LASER SAFETY FEATURES

Built-in safety features make your product more robust to real world operating conditions: latching current limit switches off the output if the current limit is reached; slow start circuit ramps the output current; and a mechanical shorting relay protects the laser from ESD events. Long-term reliability means better up-time, fewer service calls, and more customers who are satisfied with your products.

## CONTENTS

|                                  | PAGE |
|----------------------------------|------|
| QUICK CONNECT GUIDE              | 2    |
| PIN DESCRIPTIONS                 | 4    |
| ELECTRICAL SPECIFICATIONS        | 6    |
| SAFETY INFORMATION               | 7    |
| OPERATING INSTRUCTIONS           | 8    |
| ADDITIONAL TECHNICAL INFORMATION | 15   |
| TROUBLESHOOTING                  | 21   |
| MECHANICAL SPECIFICATIONS        | 23   |
| CERTIFICATION AND WARRANTY       | 24   |

## ORDERING INFORMATION

| PART NO     | DESCRIPTION               |
|-------------|---------------------------|
| PLD5K-CH    | 5 A Laser Diode Driver    |
| PLD10K-CH   | 10 A Laser Diode Driver   |
| PLD12.5K-CH | 12.5 A Laser Diode Driver |
| WCB308      | Power / LD Cable Set      |

406-587-4910

[www.teamWavelength.com](http://www.teamWavelength.com)



Applies to Product Revisions  
 PLD5K-CH & PLD10K-CH: Rev A – D  
 PLD12.5K-CH: Rev A – B  
 © January 2026



# QUICK CONNECT GUIDE



TO ENSURE SAFE OPERATION OF THE PLDXK-CH DRIVER, IT IS IMPERATIVE THAT YOU DETERMINE THAT THE UNIT WILL BE OPERATING WITHIN THE INTERNAL HEAT DISSIPATION SAFE OPERATING AREA (SOA).

Visit the Wavelength Electronics website for the most accurate, up-to-date, and easy to use SOA calculator:

[www.teamwavelength.com/support/design-tools/soa-ld-calculator/](http://www.teamwavelength.com/support/design-tools/soa-ld-calculator/)

Figure 1 shows the top view of the PLDXK-CH driver and the locations of the configuration switches, Output and Current Limit adjust trimpots, and pins.

Figure 2 shows a typical wiring diagram for the PLDXK-CH driver to operate a Type A or B laser. Refer to Table 3 on page 8 for additional wiring diagrams, or if you are using the PLD12.5K-CH.

Figure 3 illustrates the three laser types that the PLDXK-CH can drive. For detailed instructions on using the different laser types refer to the Operating Instructions.

\* DO NOT change switch positions while the output is enabled; Doing so may damage the laser diode.

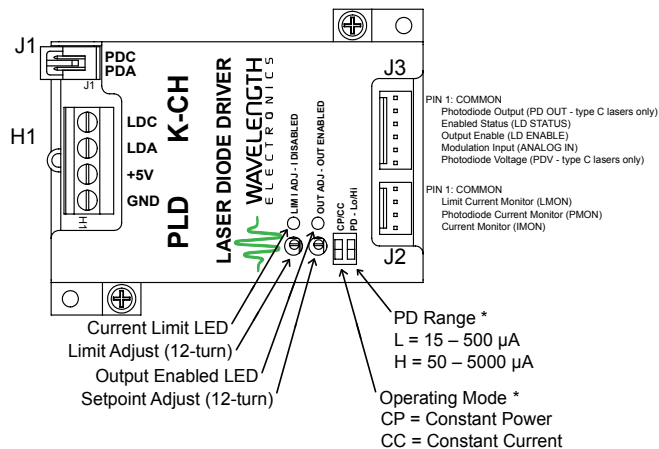

Figure 1. PLDXK-CH Driver Controls

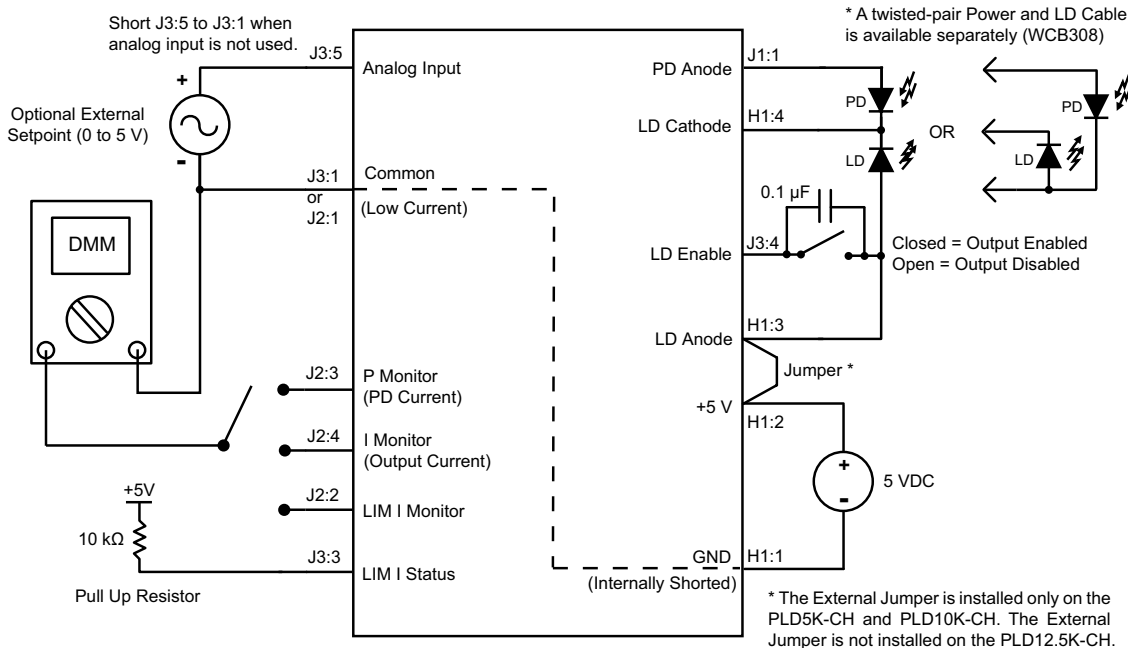

Figure 2. Quick Connect Wiring Diagram, Type A & B Laser Diodes

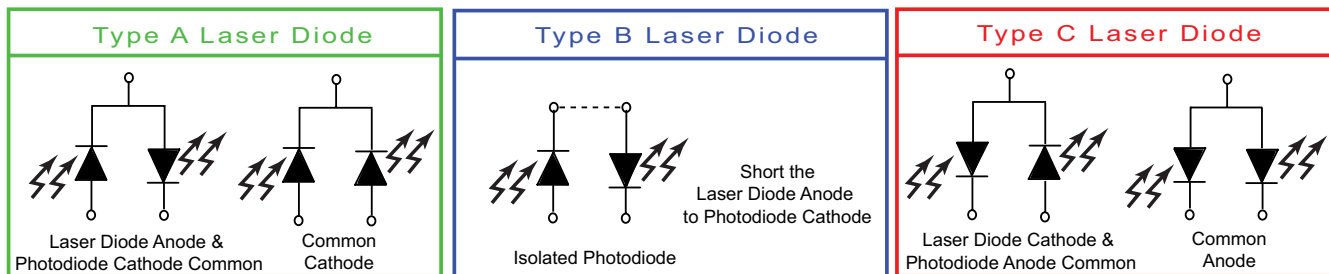
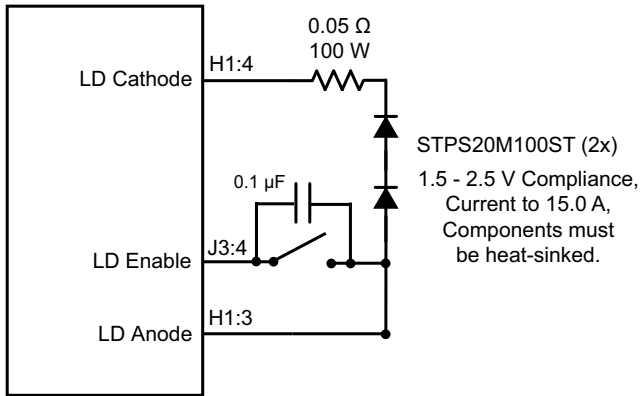

Figure 3. Laser Type Diagrams

**QUICK CONNECT GUIDE, CONTINUED**

We recommend using a test load to configure the PLDxK-CH; refer to **Figure 4**. When using the test load, the actual drive current can be determined by measuring the voltage drop across the resistor. Do not place an ammeter in series with the load circuit.



**Figure 4. Constant Current Mode Laser Test Loads**

**REVISION MARKING**

The product revision is marked in the third place of the serial number stamped on the cover. For example, CHA0852111 is a Revision A driver.

## PIN DESCRIPTIONS

Table 1. Pin Descriptions

| PIN   | NAME      | CABLE COLOR | PIN DESCRIPTION  |
|---|-----------|-------------|--|
| Connector H1; Screw terminal header; WCB308 Power/LD Cable available separately |           |             |  |
| 1   | GND       | Black       | Power Supply Ground. High current return for the <b>+5 V</b> power supply input.   |
| 2   | +5 V      | Red         | Supply voltage to control electronics. Also used to power the laser diode on the PLD5K-CH and PLD10K-CH. This pin is tied to Pin H1:3 by factory-installed external jumper on the PLD5K-CH and PLD10K-CH; cut the jumper when operating high-compliance lasers. The PLD12.5K-CH is delivered from the factory with the jumper already removed; two independent power supplies are required to operate the PLD12.5K-CH. See <b>Figure 6 on page 9</b> . |
| 3   | LDA       | White       | Laser Diode Anode. This pin is tied to Pin H1:2 by factory-installed external jumper on the PLD5K-CH and PLD10K-CH; cut the jumper when operating high-compliance lasers. The PLD12.5K-CH is delivered from the factory with the jumper already removed; two independent power supplies are required to operate the PLD12.5K-CH. See <b>Figure 6 on page 9</b> .   |
| 4   | LDC       | Blue        | Laser Diode Cathode.   |
| Connector J1, WCB307 Photodiode Cable (included)                                |           |             |  |
| 1   | PDA       | Red         | Photodiode Anode for Type A and Type B lasers. See <b>Figure 7</b> and <b>Figure 10</b> for operation with Type C laser diode packages.  |
| 2   | PDC       | Black       | Photodiode Cathode connection for Type C lasers ONLY. See <b>Figure 7</b> and <b>Figure 10</b> .   |
| Connector J2, WCB304 Monitor Cable (included)                                   |           |             |  |
| 1   | COMMON    | Black       | Measurement ground. Low current return only with monitor pins and ANALOG IN. Internally shorted to GND (pin H1:1).   |
| 2   | LMON      | White       | Current Limit Setpoint Monitor. Transfer function varies by model—refer to <b>Table 2</b> . Range 0 to 2.5 V. Impedance 1 k $\Omega$ . NOTE: Current limit needs to be set 0.2 V above desired level; see page 15 for instructions on fine-tuning the current limit.   |
| 3   | PMON      | Red         | Power Monitor (PD Current Monitor). Transfer function varies by PD feedback range setting—refer to <b>Table 2</b> . Range 0 to 2.5 V. Impedance 1 k $\Omega$ .   |
| 4   | IMON      | Green       | Laser Diode Output Current Monitor. Transfer function varies by model—refer to <b>Table 2</b> . Range 0 to 2.5 V. Impedance 1 k $\Omega$ .   |
| Connector J3, WCB305 Input/Output Cable (included)                              |           |             |  |
| 1   | COMMON    | Black       | Measurement ground. Low current return only with monitor pins and ANALOG IN. Internally shorted to GND (pin H1:1).   |
| 2   | PD OUT    | Orange      | Photodiode Output. For Type C laser diode packages only. See <b>Figure 7</b> and <b>Figure 10</b> .  |
| 3   | LD STATUS | White       | Status output pin. Indicates if the driver has reached current limit and has switched off the output. Signal is < 0.3 V if the driver is in limit and output is latched off. Signal is high impedance during normal operation. Toggle LD Enable to reset the limit circuit and enable the output current.  |
| 4   | LD ENABLE | Red         | Output Enable. Disable = ground or floating. Enable = 3 to 5 V. Requires 5 mA input current. Not TTL-compatible.   |
| 5   | ANALOG IN | Green       | Remote setpoint or modulation input. Transfer function varies by model and operating mode—refer to <b>Table 2</b> . Range 0 to 5 V. Impedance 1 M $\Omega$ . Not TTL-compatible. Connect ANALOG IN pin to Common (pin J3:1) when not using the analog input function. The ANALOG IN signal sums with the onboard setpoint value. See <b>Electrical Specifications</b> for damage threshold information.  |
| 6   | PDV       | Blue        | Photodiode Voltage. For Type C laser diode packages only. See <b>Figure 7</b> and <b>Figure 10</b> .   |

NOTE: Revision A of the PLD5K-CH and PLD10K-CH use a different connector configuration. See **Figure 17 on page 16**.

**Table 2. Current Output Monitor, Limit Monitor, Photodiode Current Monitor, and Analog Input Transfer Functions**

| <b>FUNCTION</b>   | <b>MODE</b> | <b>LABEL</b> | <b>PLD5K-CH</b> | <b>PLD10K-CH</b> | <b>PLD12.5K-CH</b> |
|---|-------------|--------------|-----------------|------------------|--------------------|
| LMON, Current Limit Setpoint Monitor                            | CC / CP     | $V_{LMON}$   | 2 A / V         | 4.6 A / V        | 5 A / V            |
| IMON, Output Current Monitor                                    | CC / CP     | $V_{IMON}$   | 2 A / V         | 4.6 A / V        | 5 A / V            |
| Analog Input; CC-Mode   | CC          |              | 1 A / V         | 2.3 A / V        | 2.5 A / V          |
| PMON, Photodiode Current Monitor Low Range                      | CC / CP     | $V_{PMON}$   | 200 $\mu$ A / V |                  |                    |
| PMON, Photodiode Current Monitor High Range <sup>See Note</sup> | CC / CP     | $V_{PMON}$   | 2 mA / V        |                  |                    |
| Analog Input CP-Mode; Low Range                                 | CP          |              | 100 $\mu$ A / V |                  |                    |
| Analog Input, CP-Mode; High Range <sup>See Note</sup>           | CP          |              | 1 mA / V        |                  |                    |

Note: High Range is not available when using Type C Lasers.

# ELECTRICAL SPECIFICATIONS

| PARAMETER  | SYMBOL           | VALUE              | UNIT | NOTE   |
|--|------------------|--------------------|------|--|
| <b>ABSOLUTE MAXIMUM RATINGS</b>  |                  |                    |      |  |
| Supply Voltage (H1:2)  | +5 V             | 5.0 to 5.5         | VDC  | See Power Supply Requirements on <b>page 8</b>   |
| Supply Voltage, (H1:3) <sup>1</sup><br>PLD12.5K-CH laser supply<br>High Compliance laser | LD Anode         | 4.5 to 30          | VDC  | Consult Safe Operating Area calculator for supply voltages > 5 VDC, see <b>page 20</b> ; PLD12.5K-CH requires two power supplies, see Power Supply Requirements on <b>page 8</b> . |
| Supply Voltage, Type C Lasers <sup>1</sup>   | Aux V+           | 8.0 to 12.5        | VDC  |  |
| Operating Temperature Range <sup>2</sup>   | T <sub>OPR</sub> | 0 to 50            | °C   |  |
| Storage Temperature Range  | T <sub>STG</sub> | -55 to 125         | °C   |  |
| Weight   |                  | 3.2                | oz   | 89.6 g   |
| Size   |                  | 1.12 x 2.35 x 3.19 | in   | 28.45 mm x 59.69 mm x 80.93 mm   |

- For two-supply operation, it is critical to shut down the power supply to the laser first before shutting down the +5V supply powering the electronics.
- Maximum operating temperature of PLD12.5K-CH is 35°C.

| PARAMETER                       | MODEL   |                 |                   | UNIT     | NOTE |
|---------------------------------|---|-----------------|-------------------|----------|------|
|                                 | PLD5K-CH  | PLD10K-CH       | PLD12.5K-CH       |          |      |
| <b>DRIVE CURRENT OUTPUT</b>     |   |                 |                   |          |      |
| Max Internal power Dissipation  | 40  |                 |                   | W        |      |
| Max Output Current              | 5 <sup>1</sup>  | 10 <sup>1</sup> | 12.5 <sup>1</sup> | A        |      |
| Compliance Voltage <sup>2</sup> | 3 V max with 5 V power supply input<br>28 V max with 30 V power supply input<br>85 V max with Product Variation |                 |                   | V        |      |
| Short Term Stability, 1 hour    | < 100   | < 200           | < 200             | ppm      |      |
| Quiescent Current               | 150   | 150             | 250               | mA       |      |
| Temperature Coefficient         | < 200   |                 |                   | ppm / °C |      |
| Noise & Ripple <sup>3</sup>     | > 45  |                 |                   | µA       |      |

|   |           |        |        |    |  |
|---|-----------|--------|--------|----|--|
| <b>PHOTODIODE FEEDBACK</b>              |           |        |        |    |  |
| High Range, Type A & B Lasers Only      | 50 - 5000 |        |        | µA |  |
| Low Range                               | 15 - 500  |        |        | µA |  |
| Constant Power Mode<br>Output Stability | < 0.02    | < 0.05 | < 0.05 | %  |  |

|   |   |          |       |      |                       |
|---|---|----------|-------|------|-----------------------|
| <b>EXTERNAL MODULATION</b>                    |   |          |       |      |                       |
| Analog Input Damage Threshold                 | -0.5 V < ANALOG IN, or<br>ANALOG IN > (Supply Voltage + 0.5V) |          |       | V    |                       |
| Input Pin Impedance                           | 1   |          |       | MΩ   |                       |
| 3 dB Bandwidth, Constant Current <sup>4</sup> | 120   | 80       | 50    | kHz  |                       |
| BW at 90% Depth of Modulation <sup>4</sup>    | 70  | 70       | 40    | kHz  | Constant Current Mode |
| Output Rise / Fall Time                       | 4.8 / 9.4   | 5.9 / 10 | 8 / 9 | µsec |                       |

|                               |      |  |  |         |  |
|-------------------------------|------|--|--|---------|--|
| <b>TIMING CHARACTERISTICS</b> |      |  |  |         |  |
| Output Turn-On Delay          | ≥1.5 |  |  | seconds |  |
| Slowstart Output On-Time      | 250  |  |  | msec    |  |
| Disable Fall Time             | >100 |  |  | µsec    |  |

|   |   |  |  |                    |  |
|---|---|--|--|--------------------|--|
| <b>MONITOR ACCURACY</b>   |   |  |  |                    |  |
| Monitor Voltage vs. Expected Output<br>based on transfer function | 2 |  |  | % of Full<br>Scale |  |

- To achieve maximum rated current, the power supply voltage may need to be 5.5 VDC because the impedance of external wiring may reduce the voltage at the laser driver.
- Compliance voltage depends on power supply voltage. In high-compliance mode, a maximum compliance voltage of 28 V is obtained using a 30 VDC power supply. A 5 VDC power supply input results in 3 V compliance voltage.
- Not recommend for low noise applications. See the [LDxCHA webpage](#) for lower noise laser drivers
- Peak-to-peak output amplitude decreases as frequency increases; see figure at right.  
Note: 90% DOM for PLD12.5K-CH is at 40 kHz.

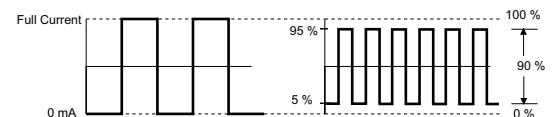

## SAFETY INFORMATION

### SAFE OPERATING AREA – DO NOT EXCEED INTERNAL POWER DISSIPATION LIMITS

Before attempting to operate the PLDxK-CH driver, it is imperative that you first determine that the unit will operate within the *Safe Operating Area* (SOA). Operating outside of the SOA may damage the laser and the PLDxK-CH. Operating outside of the SOA will void the warranty.

To determine if the PLDxK-CH driver is suitable for your application and if it will be operating in the safe range, consult the instructions for calculating the Safe Operating Area online:

[www.teamwavelength.com/support/design-tools/soa-ld-calculator/](http://www.teamwavelength.com/support/design-tools/soa-ld-calculator/)

SOA charts are included in this datasheet for quick reference (**page 20**), but we recommend you use the online tools instead.



TO ENSURE SAFE OPERATION OF THE PLDXK-CH DRIVER, IT IS IMPERATIVE THAT YOU DETERMINE IF THE UNIT IS GOING TO BE OPERATING WITHIN THE INTERNAL HEAT DISSIPATION SAFE OPERATING AREA (SOA).

If you have any questions about the Safe Operating Area calculator, call the factory for free and prompt technical assistance.

## THEORY OF OPERATION

The PLDxK-CH Series drivers are controlled current sources: they deliver the current commanded by the setpoint. The current source continually monitors the actual output current, compares it to the setpoint, and adjusts the current if there is a difference between the two signals.

It may be useful to remember that you do not directly set the drive current setpoint; instead, you adjust a voltage signal that represents the output current. The voltage and output current are related by a transfer function that varies by driver model number.

The setpoint voltage is adjusted with the onboard trimpot or by an external input that sums with the onboard setpoint. The adjustable current limit is set using an onboard trimpot.

As current is driven through the load, there is a voltage drop across the load because of the impedance. As the current increases, the voltage drop may increase to the point that it reaches the Compliance Voltage limit of the current source. Once that occurs, the current source is no longer able to increase the current driven to the load even if you increase the setpoint.

The PLDxK-CH driver includes features that help protect your laser and make the driver more versatile in a wide array of applications:

- The user-adjustable latching current limit protects the laser from over-current situations by switching off the output when a limit condition is detected. Toggling the Enable resets the current limit circuit.
- Output current switches on after approximately 1.5 seconds from the time the Enable signal is applied.
- Output slow-start ramps the current to setpoint over 250 msec.

## OPERATING INSTRUCTIONS

The PLDxK-CH requires no external electronic components.

The driver is first configured for local control in order to set the drive current limit. Then the driver is reconfigured according to the actual application.

We recommend using a test load until you are familiar with operation of the driver. Refer to **page 3** for test load schematics.

### NECESSARY EQUIPMENT

The following equipment is the minimum necessary to configure the PLDxK-CH for basic operation:

- PLDxK-CH controller
- Digital voltmeter, 4-½ digit resolution recommended
- Test load for configuring the driver
- Laser diode, mount, and optional temperature control system
- Connecting wires
- Power supply (see below)

### POWER SUPPLY REQUIREMENTS

Linear-regulated or low-noise switching power supplies can be used. We recommend using power supplies with noise specifications suitable for your application.

For single-supply operation, PLD5K-CH and PLD10K-CH:

- 5 VDC power supply rated for 1.1-times the maximum laser diode current, plus 150 – 250 mA for the electronics (see **Electrical Specifications**)

For Type C lasers with the PLD5K-CH and PLD10K-CH:

- 8 to 12 VDC power supply rated for 250 mA, plus 1.1-times the maximum laser diode drive current; power regulation circuitry is also required (see **Figure 7** and **Figure 10**)
- OR a 5 VDC power supply for the PLDxK-CH driver electronics (rated for 150 – 250 mA) and an 8 to 12 VDC power supply for the laser, rated for 1.1-times the maximum laser diode current

For two-supply operation when using the PLD5K-CH or PLD10K-CH to drive a high-compliance laser, laser bar, or laser stack; Use these criteria for the PLD12.5K-CH:

- 5 VDC power supply rated for 250 mA for electronics
- AND a power supply to drive the laser; rated for 1.1-times the maximum laser diode drive current and > 2 V greater than the compliance voltage of the laser

**NOTE: It is critical to shut down the power supply to the laser first before shutting down the +5V supply powering the electronics. Failure to follow this order may damage the PLD or laser.**

## SAFE OPERATING AREA AND THERMAL DESIGN CONSIDERATIONS

SOA charts are included in this datasheet for quick reference, but we recommend you use the online tools instead.

[www.teamwavelength.com/support/design-tools/soa-ld-calculator/](http://www.teamwavelength.com/support/design-tools/soa-ld-calculator/)



IT IS IMPERATIVE THAT YOU VERIFY THE UNIT WILL OPERATE WITHIN THE INTERNAL HEAT DISSIPATION SAFE OPERATING AREA (SOA).

OPERATING THE DRIVER OUTSIDE THE SOA MAY DAMAGE OR DESTROY THE DRIVER AND/OR LASER.

### PREVENT DAMAGE FROM ELECTROSTATIC DISCHARGE

Before proceeding, it is critical that you take precautions to prevent electrostatic discharge (ESD) damage to the driver and your laser. ESD damage can result from improper handling of sensitive electronics, and is easily preventable with simple precautions.

Enter the search phrase “ESD Precautions for Handling Electronics” in an internet search engine to find information on ESD-safe handling practices.

We recommend that you always observe ESD precautions when handling the PLDxK-CH driver and your laser diode.

Note: The PLDxK-CH case is isolated from electrical ground.

### WIRE THE PLDxK-CH LASER DRIVER

Refer to **Table 3** for wiring instructions specific to your configuration. For setup and configuration use a test load (see **Figure 4**).

**Table 3. Wiring Configurations**

| PRODUCT               | CONFIGURATION   | DIAGRAM          |
|-----------------------|---|------------------|
| PLD5K-CH<br>PLD10K-CH | Type A & B Laser Diode,<br>Single 5 VDC Power Supply                        | <b>Figure 5</b>  |
|                       | Type A & B Laser Diode,<br>High-Compliance Laser                            | <b>Figure 6</b>  |
|                       | Type C Laser Diode,<br>Single Power Supply                                  | <b>Figure 7</b>  |
|                       | Type A & B Laser Diode,<br>Negative Power Supply or<br>Grounded Laser Anode | <b>Figure 8</b>  |
| PLD12.5K-CH           | Type A & B Laser Diode  | <b>Figure 9</b>  |
|                       | Type C Laser Diode  | <b>Figure 10</b> |
|                       | Type A & B Laser Diode,<br>Negative Power Supply or<br>Grounded Laser Anode | <b>Figure 11</b> |

WIRING THE PLD5K-CH AND PLD10K-CH

Figure 5. Type A & B Laser Diode, Single 5 VDC Power Supply  
PLD5K-CH and PLD10K-CH

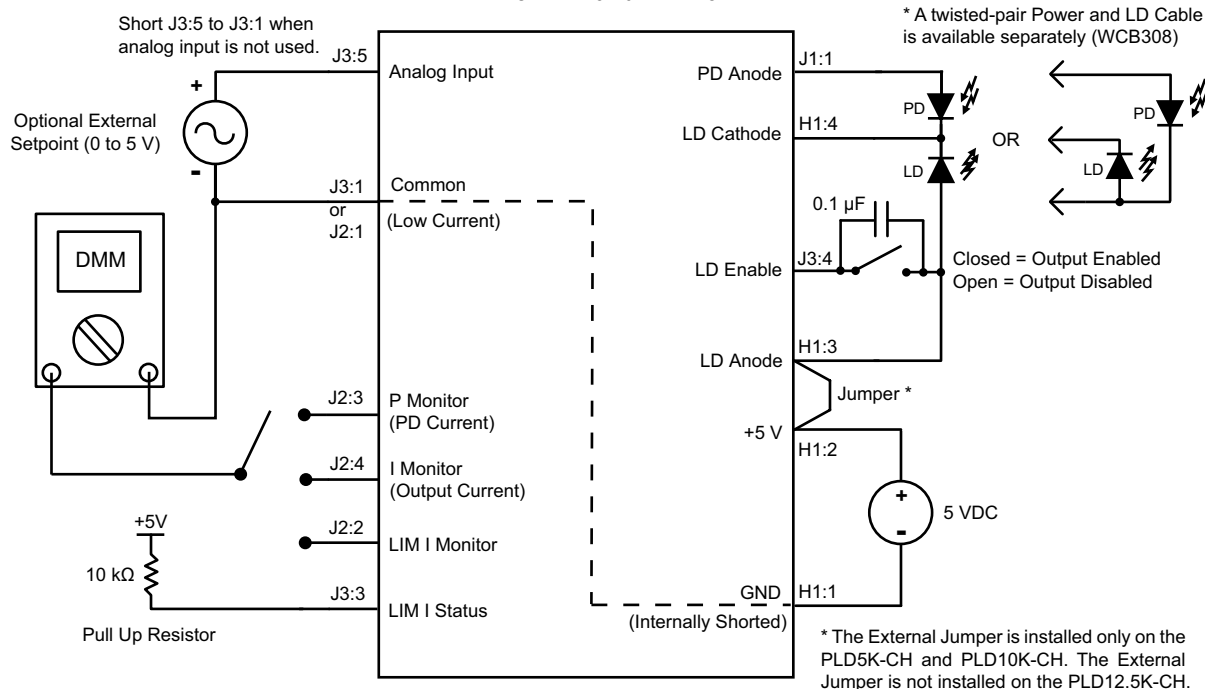
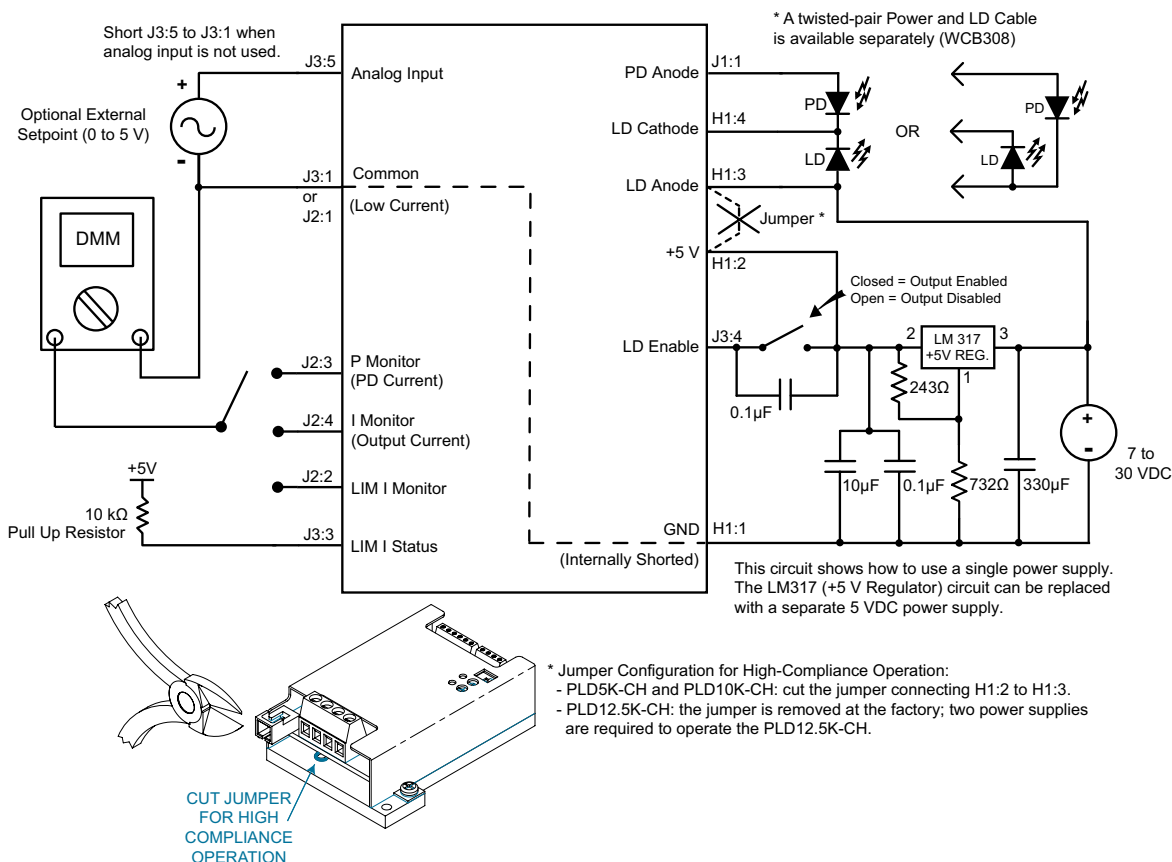

Figure 6. High-Compliance Laser Diode Operation  
PLD5K-CH and PLD10K-CH



**NOTE:** For two-supply operation, it is critical to shut down the power supply to the laser first before shutting down the +5V supply powering the electronics.

WIRING THE PLD5K-CH AND PLD10K-CH (CONTINUED)

Figure 7. Type C Laser Diode; PLD5K-CH and PLD10K-CH

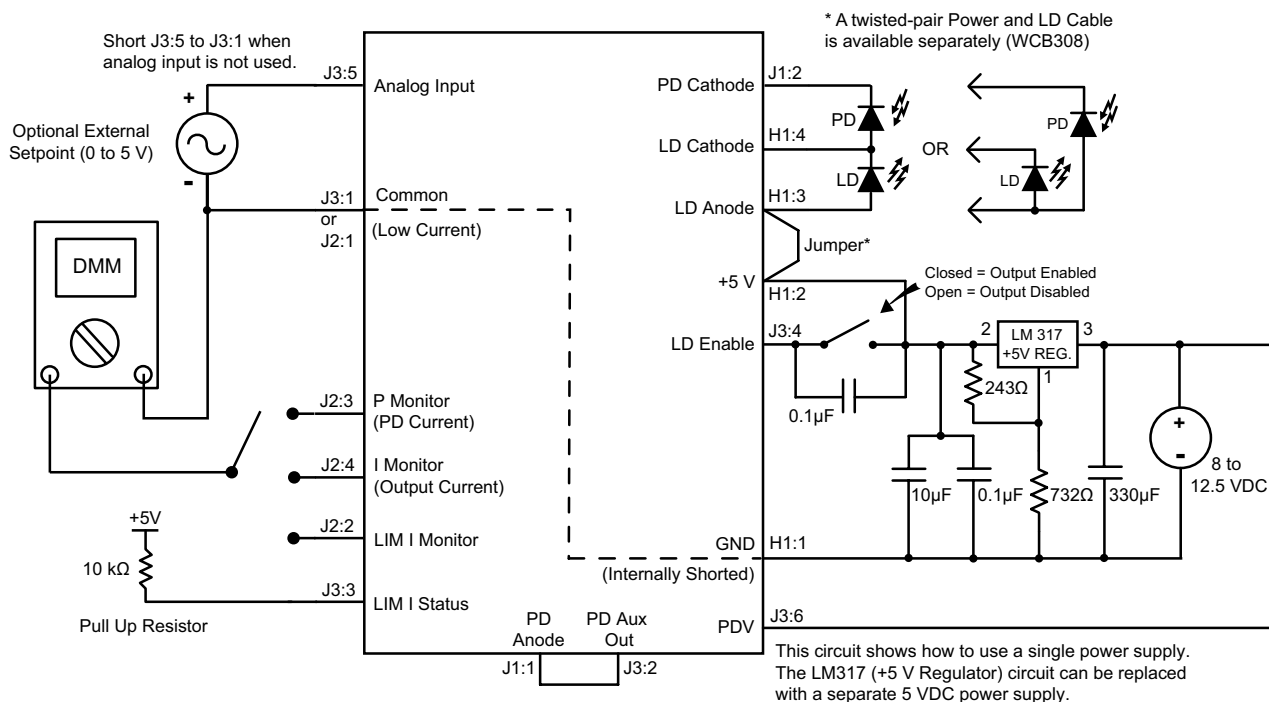

\* The External Jumper is installed only on the PLD5K-CH and PLD10K-CH. The External Jumper is not installed on the PLD12.5K-CH.

Figure 8. Type A & B Lasers, Negative Power Supply Operation; PLD5K-CH and PLD10K-CH

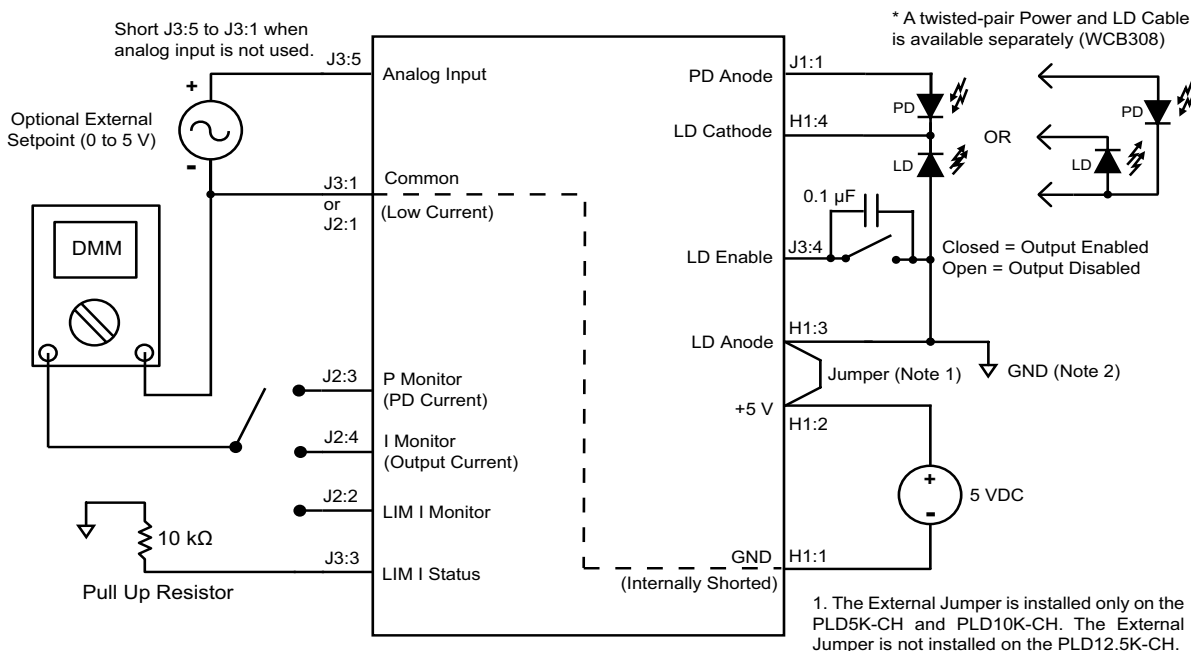

1. The External Jumper is installed only on the PLD5K-CH and PLD10K-CH. The External Jumper is not installed on the PLD12.5K-CH.

2. Isolate this ground connection from Earth if there are any other Earth-grounded components in the system.

**NOTE:** For two-supply operation, it is critical to shut down the power supply to the laser first before shutting down the +5V supply powering the electronics.

WIRING THE PLD12.5K-CH

Figure 9. Type A & B Laser Diode, Using Two Power Supplies; PLD12.5K-CH

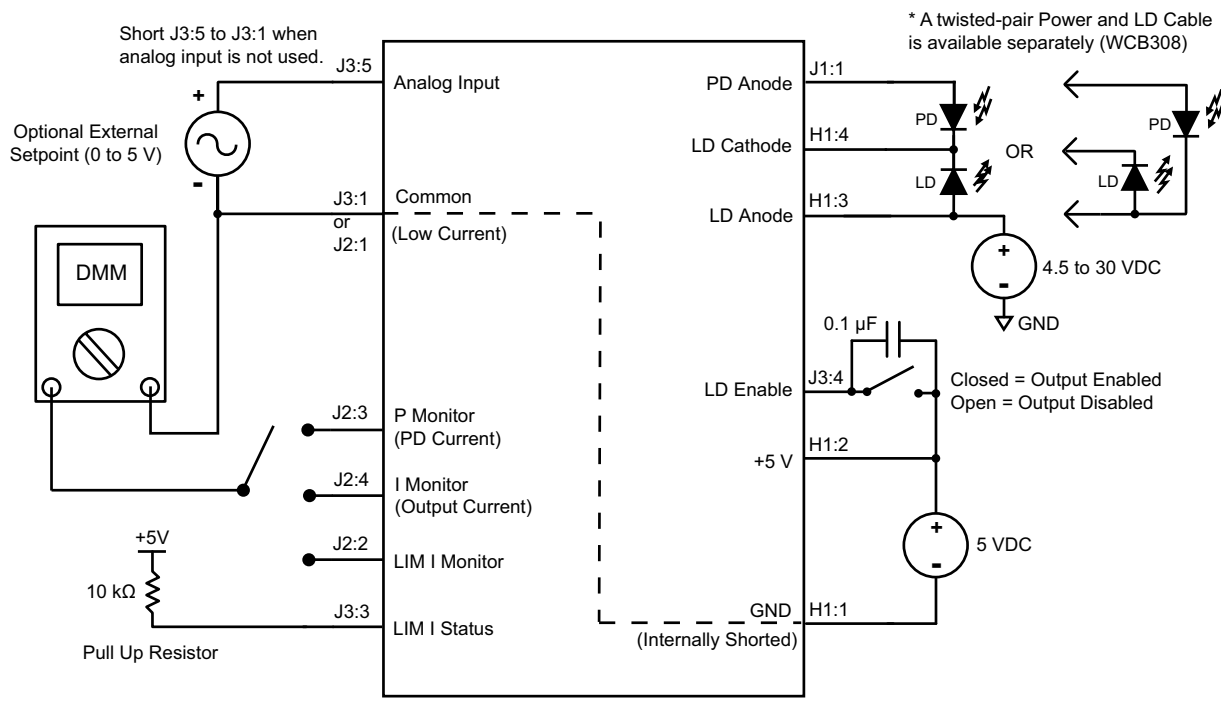
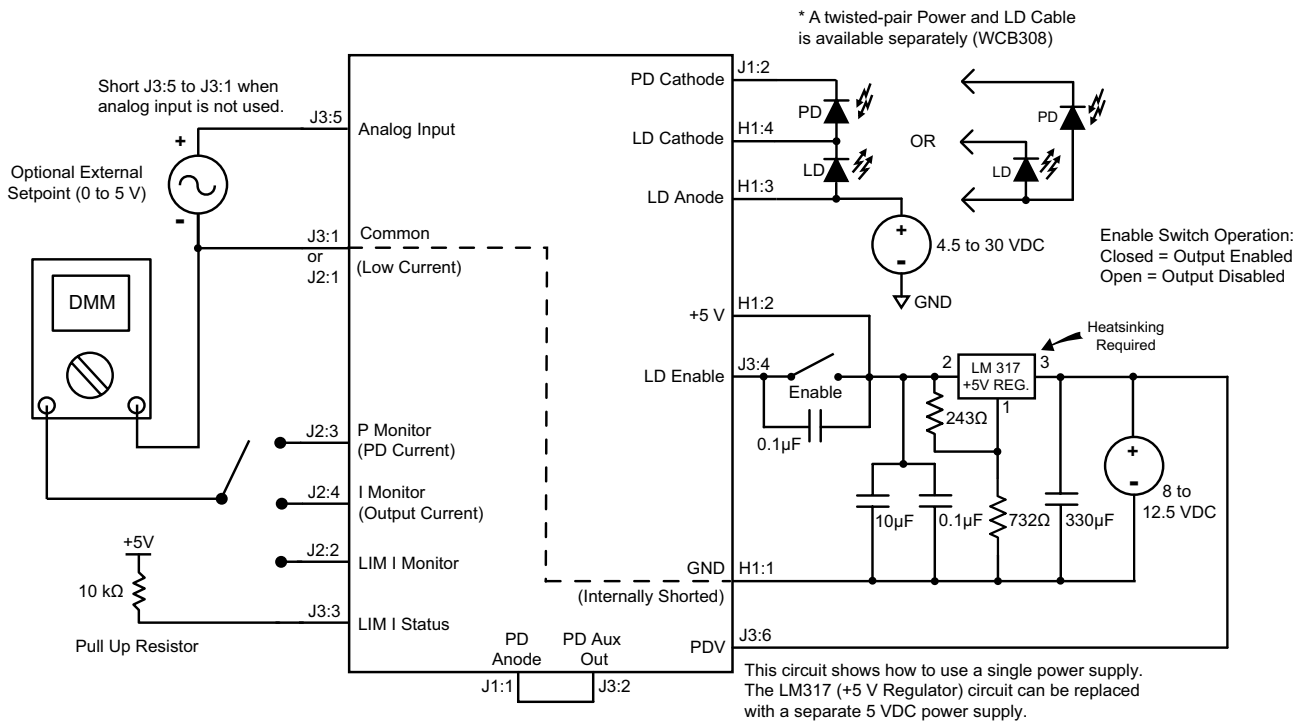

Figure 10. Type C Laser Diode Operation; PLD12.5K-CH



**NOTE:** For two-supply operation, it is critical to shut down the power supply to the laser first before shutting down the +5V supply powering the electronics.

WIRING THE PLD12.5K-CH (CONTINUED)

Figure 11. Type A & B Laser Diode, Negative Power Supply Operation; PLD12.5K-CH

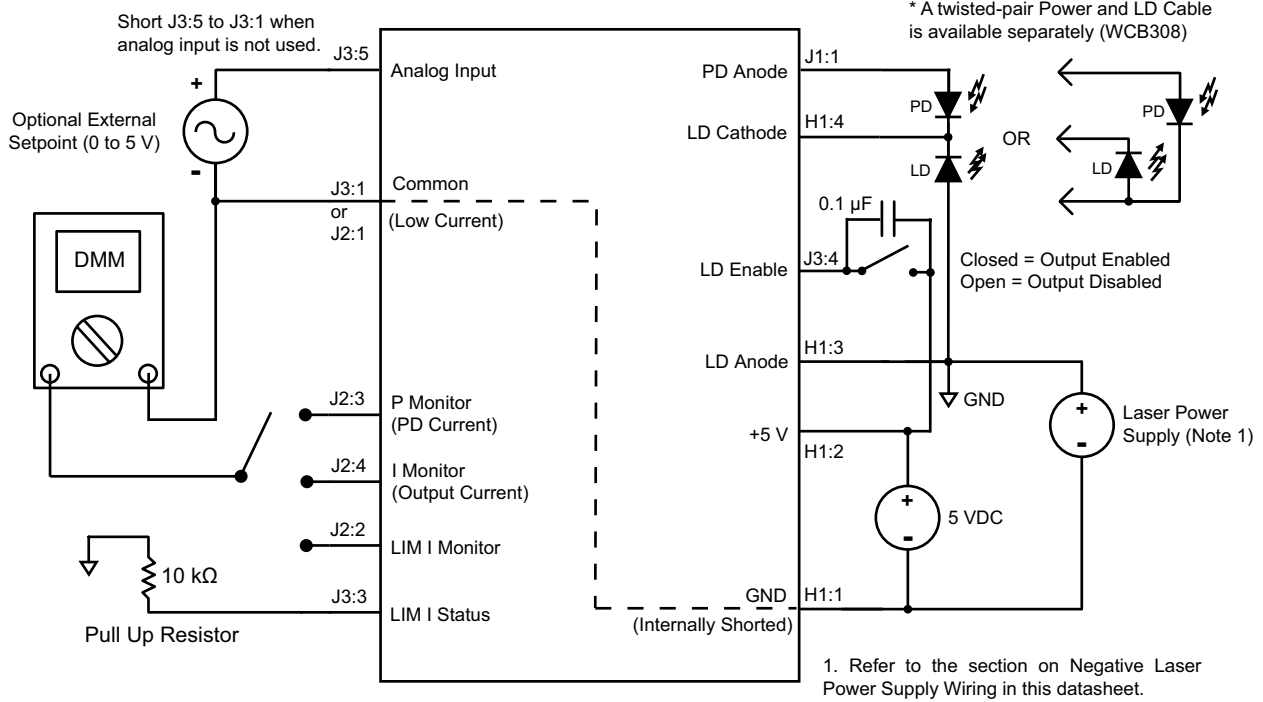

**NOTE:** For two-supply operation, it is critical to shut down the power supply to the laser first before shutting down the +5V supply powering the electronics.

## ONBOARD ADJUSTMENTS AND CONTROLS

Onboard controls are on the top of the PLDXK-CH and must be set according to the operation mode. The controls are illustrated in **Figure 12**.

 \* DO NOT change switch positions while the output is enabled; Doing so may damage the laser diode.

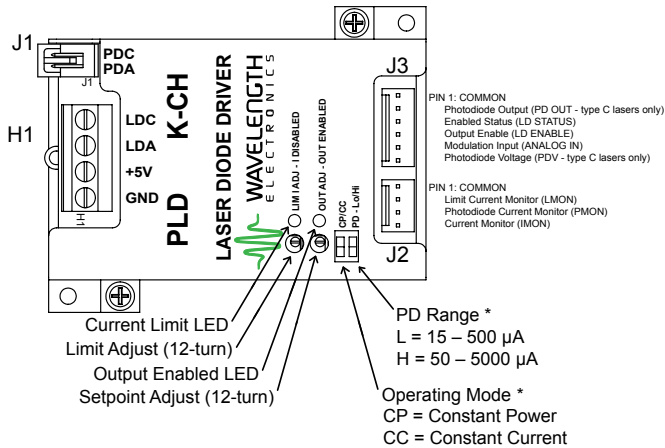

Figure 12. PLD Driver Adjustments and Controls

## SET THE CONTROL MODE

Set the MODE switch to CP (left) for Constant Power mode operation, or to CC (right) for Constant Current mode. Constant Power mode operation requires a photodiode feedback loop from the laser diode.



DO NOT SWITCH THE CONTROL MODE WHILE THE OUTPUT IS ENABLED AND DRIVING A LASER DIODE. THE LASER DIODE MAY BE DAMAGED OR DESTROYED.

## SET THE PHOTODIODE RANGE

Two photodiode feedback current ranges are available on the PLDXK-CH drivers. Reference the datasheet for your laser diode to find the nominal photodiode current, and set the PD RANGE switch as follows:

- Lo (left) = Low Range, PD current 15 – 500 µA
- Hi (right) = High range; PD current 50 – 5000 µA



DO NOT SWITCH THE PD RANGE WHILE THE OUTPUT IS ENABLED AND DRIVING A LASER DIODE. THE LASER DIODE MAY BE DAMAGED OR DESTROYED.

## CALCULATE THE MONITOR VOLTAGES

Refer to the datasheet for your laser to determine the maximum forward current, and calculate the current limit monitor voltage ( $V_{L\text{MON}}$ ) using this equation and the transfer function found in **Table 2 on page 5**:

$$V_{L\text{MON}} = I_{L\text{LIMIT}} / \text{Transfer Function}$$

If you are using the PLDXK-CH in Constant Current mode, calculate the monitor voltage for the drive current setpoint. Refer to the datasheet for your laser to determine the nominal forward current, and calculate the IMON voltage using the transfer function found in **Table 2**:

$$V_{I\text{MON}} = I_{LD} / \text{Transfer Function}$$

If you are using the PLDXK-CH in Constant Power mode, calculate the photodiode current monitor voltage, PMON. Refer to the laser diode datasheet to determine the nominal photodiode current at the desired operating point. Calculate the PMON voltage using the transfer function found in **Table 2**:

$$V_{P\text{MON}} = I_{PD} / \text{Transfer Function}$$

## SET THE CURRENT LIMIT

Connect the positive lead of the digital multimeter to the LMON pin (J2:2), and the negative lead to the COMMON terminal.

Reference **Figure 1** for control locations on the PLDXK-CH:

- Ensure the external Enable switch is OPEN.
- Switch on the 5 volt power supply to the PLDXK-CH.
- Set the **OUT ADJUST** trimpot to zero by turning at least 12 turns counter-clockwise.
- Set the current limit by turning the LIM I ADJUST trimpot until the voltage displayed on the multimeter matches the value calculated above.

Switch off the power supply.

The PLDXK-CH controllers trip the current limit circuit below the expected limit level, by 0.2 V on the monitor. To trip the current limit at exactly the desired current level, refer to **Set the Current Limit More Accurately on page 15** to fine-tune the current limit.

## ADJUST THE OUTPUT CURRENT SETPOINT—ONBOARD CONTROL

To increase the output current, turn the onboard trimpot clockwise; turn counter-clockwise to decrease output current.

While adjusting the output current, measure the voltage on pin J2:4, IMON. Use the transfer function listed in **Table 2** to determine the output current from the monitor voltage.

## ADJUST THE OUTPUT CURRENT SETPOINT—ANALOG INPUT

To use ANALOG IN (pin J3:5) to adjust the output current, refer to Pin Descriptions on **page 4** for specifications. The analog input signal sums with the onboard trimpot value.

The analog input signal can be used whether the driver is operating in Constant Current or Constant Power mode. Refer to **Table 2 on page 5** for the transfer functions for CC and CP modes.

Refer to the External Setpoint Circuit on **page 16** for an example analog input circuit. Other circuits, a DAC signal, or function generator may be used. The analog input pin is not designed for use with TTL signals.

## COMBINING THE ONBOARD SETPOINT AND ANALOG INPUT

The ANALOG IN voltage signal on J3:5 sums with the onboard trimpot setpoint. This configuration allows the driver to be configured so that the laser current or power modulates around a DC setpoint.

If the sum of the two signals causes the PLDxK-CH to attempt to drive the output current past the limit, the output will switch off and indicate a current limit error.

To avoid driving the current to the limit, first set the onboard trimpot to produce the Constant Current level. Then connect the modulation source to the ANALOG IN pin and slowly increase the modulation amplitude. Monitor the output current using the IMON pin, or by measuring the voltage across the test load. Do not monitor the voltage across a laser diode—measurement transients may damage the laser diode.

## CURRENT LIMIT CIRCUIT TRIGGER AND RESET

If the PLDxK-CH detects current limit, the output will switch off and the I DISABLED LED on the top of the unit will illuminate red and the **LD Status** voltage will drop to ground. Set the Enable switch to OFF, correct the cause of the error, and then re-enable the output.

## MONITOR THE PHOTODIODE CURRENT

If the photodiode is connected to the PLDxK-CH, the current can be monitored by connecting a multimeter to the PMON pin, J2:3, and reading the voltage. Refer to **Table 2 on page 5** for the transfer function to convert the PMON voltage to PD current.

When using Type C lasers, the PD Range switch must be set to LO.

## ADDITIONAL TECHNICAL INFORMATION

This section includes useful technical information on these topics:

- Remote Limit Status LED Circuit
- Set the Current Limit More Accurately
- Change the Photodiode Range, Type A & B Lasers
- Change the Photodiode Range, Type C Lasers
- Change the Analog Input Modulation Transfer Function
- External Setpoint Circuit
- Important Information on Grounding
- Fine Tune Deep Modulation
- PLD5K-CH and PLD10K-CH Revision A
- Cable Lengths and High Current
- Add Laser Diode Protection for Long Cables
- Additional Noise Filtering
- Monitor Calibration Circuit
- Revision B Timing Characteristics
- Product Variations
- Negative Laser Power Supply Wiring
- Output On/Off and Current Limit Timing
- Parallel PLDs for Higher Current
- Power Supplies and Noise
- Safe Operating Area Calculation

### REMOTE LIMIT STATUS LED CIRCUIT

The LD STATUS feature can be used to drive a remote LED in your control system. The driver has a built-in 332 Ω current limit resistor between pin J3:3 and ground. Connect the external LED as shown in **Figure 13**.

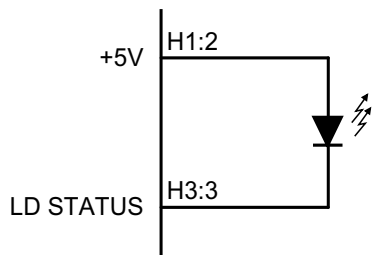

Figure 13. Remote LIM I Status LED

### SET THE CURRENT LIMIT MORE ACCURATELY

The current limit circuit is designed with a small hysteresis, which causes the limit circuit to trip at a slightly lower current than calculated. To fine-tune the current limit, a small offset voltage must be factored in. Use this equation to calculate the hysteresis offset, where  $V_{+5V}$  is the supply voltage:

$$\text{Offset (V)} = (V_{+5V} - V_{MON}) / 25.9$$

Then add the Offset to  $V_{LIMIT}$  calculated on **page 13**.

### CHANGE THE PHOTODIODE RANGE, TYPE A & B LASERS

The photodiode current range and transfer function can be adjusted by adding an external resistor. This feature is useful when the photodiode current of your laser falls in a range that does not allow maximum measurement sensitivity on the PLDxK-CH driver.

**Figure 14** shows the internal resistor network of the PLDxK-CH, and the equations explain the interaction with the external resistor. Use a ¼ W resistor for R.

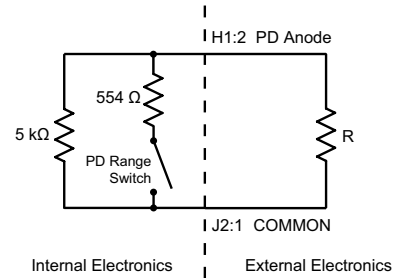

|  |   |
|--|---|
| PD Range = L   | PD Range = H  |
| $\text{Range} = \frac{2.5 \text{ V} * 10^6}{R \parallel 5 \text{ k}\Omega} \mu\text{A}$        | $\text{Range} = \frac{2.5 \text{ V} * 10^6}{R \parallel 500 \Omega} \mu\text{A}$        |
| $\text{Transfer Function} = \frac{10^6}{R \parallel 5 \text{ k}\Omega} \mu\text{A} / \text{V}$ | $\text{Transfer Function} = \frac{10^6}{R \parallel 500 \Omega} \mu\text{A} / \text{V}$ |
| $R \parallel 5 \text{ k}\Omega = \frac{R * 5000}{R + 5000} \Omega$                             | $R \parallel 500 \Omega = \frac{R * 500}{R + 500} \Omega$                               |

Figure 14. Adjusting the PD Range, Type A & B Lasers

### CHANGE THE PHOTODIODE RANGE, TYPE C LASERS

The photodiode range and transfer function can be adjusted when using Type C lasers by connecting a ¼ W resistor between the PD Cathode (pin J1:2) and PDV (pin J3:6).

The PD current range is calculated (units are amps):

$$\text{Range} = 2.5 \text{ V} / (R \parallel 5 \text{ k}\Omega)$$

The transfer function is calculated (units are A / V):

$$\text{Transfer Function} = 1 / (R \parallel 5 \text{ k}\Omega)$$

The value of  $(R \parallel 5 \text{ k}\Omega)$  is calculated as follows (units are Ω):

$$(R \parallel 5 \text{ k}\Omega) = (R * 5000) / (R + 5000)$$

## CHANGE THE ANALOG INPUT MODULATION TRANSFER FUNCTION

The analog input modulation transfer function can be changed by adding a voltage divider resistor network external to the PLDxK-CH driver. **Figure 15** illustrates a simple circuit.

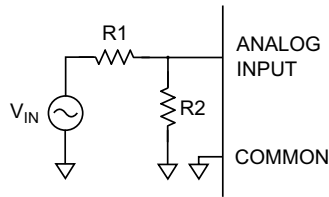

Keep R1 and R2 below 100 kΩ for maximum accuracy.

$$\text{New Transfer Function} = \frac{R2}{R2 + R1} * \text{Old Transfer Function}$$

Example: R1 = 9 kΩ  
(for PLD10K-CH) R2 = 1 kΩ

$$\text{New Transfer Function} = \frac{1}{1 + 9} * 2.3 \text{ A/V} = 230 \text{ mA/V}$$

**Figure 15. Changing the Analog Input Modulation Transfer Function**

## EXTERNAL SETPOINT CIRCUIT

An external trimpot circuit can be used to adjust the laser current setpoint; refer to **Figure 16**.

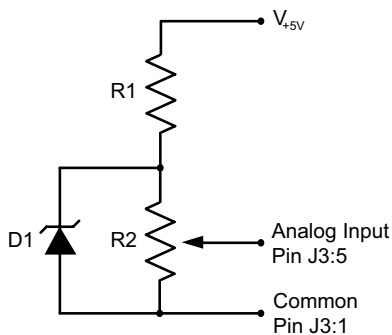

V<sub>+5V</sub> = Supply voltage (5 to 30 V)  
D1 = Bandgap reference\* (LM4040)  
R1 = 2.2 kΩ, 1 W resistor  
R2 = Trimpot, 10 kΩ to 100 kΩ

\*V<sub>+5V</sub> must be at least 1 volt greater than the voltage value of D1.

**Figure 16. Trimpot Circuit for Analog Input**

## IMPORTANT INFORMATION ON GROUNDING

Some laser diodes connect the laser anode or cathode to the case. In such cases special attention must be paid to grounding to ensure safe operation of the PLDxK-CH and laser.



IT IS CRITICAL THAT THE PLDXK-CH DRIVER IS PROPERLY GROUNDED. IF THE PLDXK-CH DRIVER IS USED WITH A WAVELENGTH ELECTRONICS TEMPERATURE CONTROLLER, YOU MAY NEED TO USE TWO SEPARATE POWER SUPPLIES THAT FLOAT INDEPENDENTLY OF EACH OTHER.

If the laser anode is connected to the laser case, it is possible that the anode will be connected to earth ground when the laser is installed in a benchtop mount or in your laser system. In situations where the laser diode is connected to the case, it is critical that the negative terminal of the power supply remain isolated from earth ground.

## FINE TUNE DEEP MODULATION

If the analog modulation input is near the rail (> 4.5 V), output current signal response may be insufficient. Performance may be improved by connecting a quality low-ESR 470 μF, 16 V electrolytic capacitor between the power terminals (pins H1:1 and H1:2). This decoupling capacitor should be directly connected at the PLDxK-CH.

## PLD5K-CH AND PLD10K-CH REVISION A

Revision A of the PLD5K-CH and PLD10K-CH use a different connector configuration than later revisions. **Figure 17** shows the connector configuration.

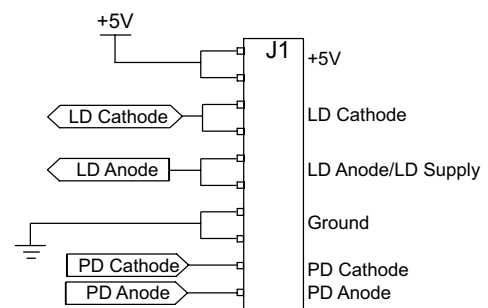

**Figure 17. Revision A Connector PLD5K-CH and PLD10K-CH**

### CABLE LENGTHS AND HIGH CURRENT

The length and gauge of cable from the power supply or to the laser diode can impact performance. The resistance and inductance of the wire can reduce bandwidth or cause the voltage to the PLDxK-CH to droop.

If the output current starts to oscillate as setpoint voltage approaches the limit setting, then the power supply cables may be too long. If you cannot shorten the cables, place a 470  $\mu$ F capacitor across pins H1:1 and H1:2 to minimize droop. Always twist the wire pairs to eliminate reactance.

### ADD LASER DIODE PROTECTION FOR LONG CABLES

With a cable longer than two feet, add a Schottky diode across the laser diode, see **Figure 18**.

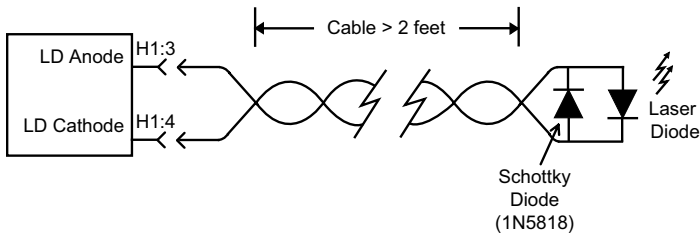

Figure 18. Long Cable Laser Protection

### ADDITIONAL NOISE FILTERING

The PLDxK-CH drivers provide low-noise current to the laser diode, but in some cases additional filtering may be needed. Refer to **Figure 19** for a simple and effective filter.

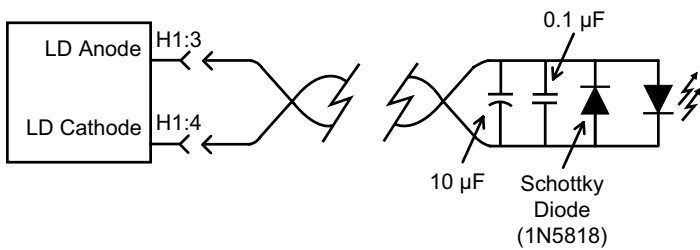

Figure 19. PLDxK-CH Output Filter

### MONITOR CALIBRATION CIRCUIT

A small offset may be present when measuring the PMON, IMON or LMON voltage with respect to the actual output. Use the circuit shown in **Figure 20** to remove any offset.

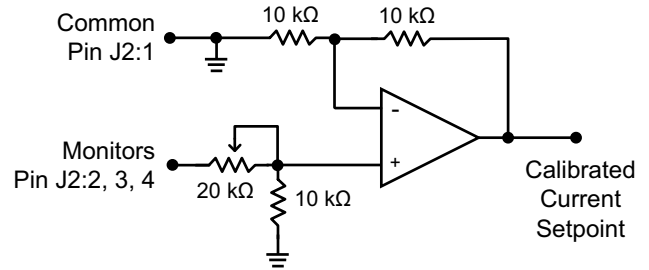

Figure 20. Monitor Calibration Circuit

### REVISION B TIMING CHARACTERISTICS

**Table 4** describes the timing and bandwidth characteristics of the PLDxK-CH Series Revision B units.

Table 4. Output Timing, Revision B

| MODEL     | TURN-ON TIME  | TURN-OFF TIME | SLOWSTART DELAY |
|-----------|---------------|---------------|-----------------|
| PLD5K-CH  | 6.8 $\mu$ sec | 6.8 $\mu$ sec | $\geq 1.5$ sec  |
| PLD10K-CH | 10 $\mu$ sec  | 12 $\mu$ sec  | $\geq 1.5$ sec  |

### PRODUCT VARIATIONS

We design and manufacture our products in-house, and that gives us the unique ability to modify our drivers and controllers to suit your application. Our Product Variation service allows us to quickly and cost-effectively address your design requests, from prototype quantities to long-term high-volume manufacturing.

Examples of past Product Variations include:

- Increasing the compliance voltage limit
- Replacing current limit trimpots with fixed-value resistors to maximize long-term stability in an OEM laser controller system
- Changing the controller input voltage

## NEGATIVE LASER POWER SUPPLY WIRING

Connecting the laser anode to ground will give the best low-noise performance. The PLDxK-CH can be configured to drive the electronics and the laser with separate power supplies, and this flexibility allows the laser anode to be grounded.

Connecting the laser driver power supply in this way is effectively the same as driving the laser with a “negative” power supply. See **Figure 21** for a basic wiring diagram.

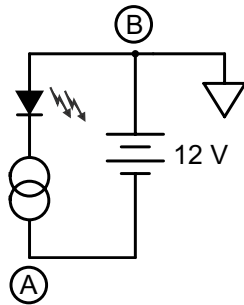

**Figure 21. Basic Negative Supply Operation**

The voltage at the cathode (Point A) is 12 volts negative with respect to the anode (Point B). Therefore, since the anode is grounded, the voltage at the cathode is -12 V with respect to ground. Effectively, the laser is driven by a -12 V power supply.

The laser anode can be connected to earth ground, but only if no other components in the system are earth-grounded.

## POWER THE PLDxK-CH

The PLD5K-CH and PLD10K-CH can use a single power supply for the laser and the electronics if the forward voltage of the laser diode is not too great. **Figure 8 on page 10** illustrates single-supply operation with the laser driven by a negative voltage power supply.

The PLD5K-CH and PLD10K-CH can also be configured to use a separate negative voltage laser power supply if the forward voltage of the laser is greater than the compliance voltage of the driver. The PLD12.5K-CH requires separate power supplies for the laser and electronics. In all these cases, the laser can be driven by a negative voltage power supply for the best possible noise performance.

The electronics of the PLDxK-CH driver must be biased by a 5 V power supply; configuring the driver requires care when a negative voltage power supply is used to drive the laser.

Two configurations are explained below. These two configurations accomplish the same function, which is to provide a 5 V bias across the electronics. Since the electronics and laser current source are internally grounded, the voltage at Point C must be 5 V positive with respect to Point A.

The first solution is to connect a 5 V power supply across the driver electronics; see **Figure 22** (this is the same configuration shown in **Figure 8**). This solution offers two advantages:

- **Simplicity:** a external 5 V power supply is easy to procure, or can easily be designed into a laser control system.
- **Noise performance:** the power supply and the electronics share the ground reference point, so even if the voltage at Point A fluctuates (with respect to ground), the bias across the control electronics remains constant. This effect is called Common Mode Noise Rejection, and may be important if the laser drive current is modulated.

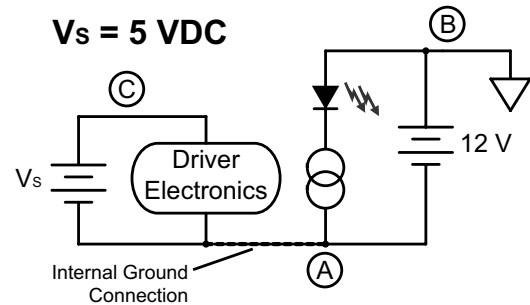

**Figure 22. Negative Supply Operation, 5 V Electronics Power Supply**

Another solution is to bias the electronics with a power supply in series with the control electronics, shown in **Figure 23**. This solution is less favorable because noise and fluctuations in the voltage at Point A will directly impact the voltage across the control electronics.

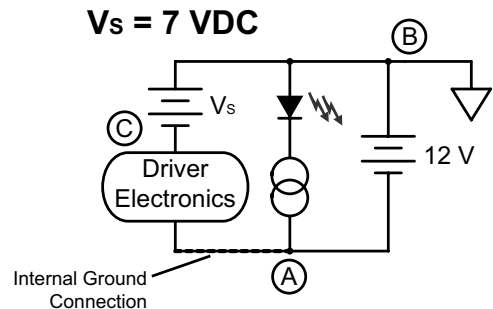

**Figure 23. Negative Supply Operation, 7 V Electronics Power Supply**

### OUTPUT ON/OFF AND CURRENT LIMIT TIMING

Figure 24 through Figure 26 illustrate the output turn-on delay, output rise and fall times, and current limit response.

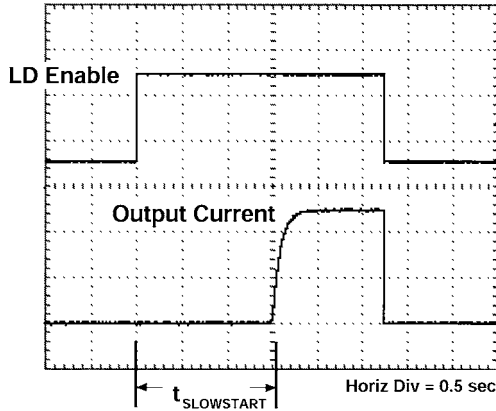

Figure 24. Output Turn-On Delay

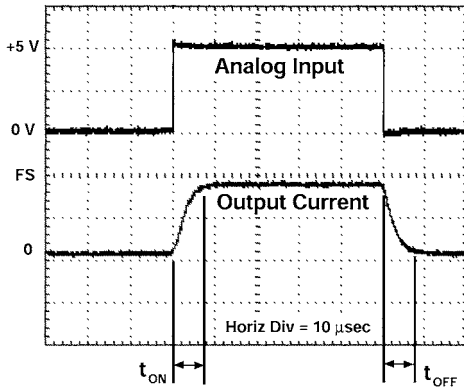

Figure 25. Output Rise / Fall-Time

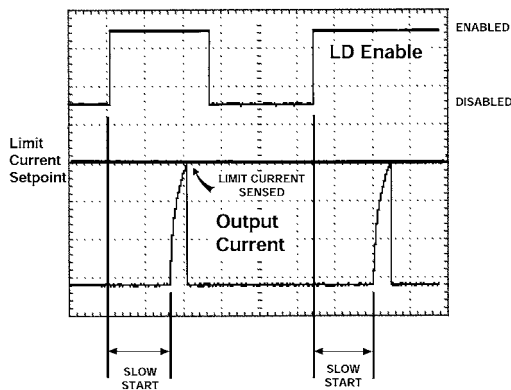

Figure 26. Current Limit Response

### PARALLEL PLDS FOR HIGHER CURRENT

Multiple PLDxK-CH drivers can be connected in parallel to drive higher current. Contact the factory for more information on how to do this safely, or see Application Note AN-LD06: [www.teamwavelength.com/download/applicationtechnotes/an-ld06.pdf](http://www.teamwavelength.com/download/applicationtechnotes/an-ld06.pdf)

### POWER SUPPLIES AND NOISE

The PLDxK-CH drivers deliver stable current with low noise, but the power supply you use will directly influence the noise performance of the driver.

We recommend using a regulated linear supply for the best noise performance, but depending on your application requirements you may be able to use a switching power supply. Each case must be evaluated because a switching power supply will affect noise, transient, and stability performance. Wavelength offers an evaluation kit for easy configuration and operation.

## SAFE OPERATING AREA CALCULATION

The Safe Operating Area of the PLDxK-CH driver is determined by the amount of power that can be dissipated within the output stage of the driver. If that power limit is exceeded, permanent damage can result.



DO NOT OPERATE THE PLDXK-CH DRIVER OUTSIDE OF THE SAFE OPERATING AREA CURVE.

OPERATING THE PLDXK-CH DRIVER OUTSIDE OF THE SOA VOIDS THE WARRANTY.

Refer to the Wavelength Electronics website for the most up-to-date SOA calculator for our products. The online tool is fast and easy to use, and also takes into consideration operating temperature.

[www.teamwavelength.com/support/design-tools/soa-ld-calculator/](http://www.teamwavelength.com/support/design-tools/soa-ld-calculator/)

SOA charts are included in this datasheet for quick reference, however we recommend you use the online tools instead.

Follow these steps to determine if the driver will be operating within the SOA.

- Refer to the laser diode datasheet to find the maximum voltage ( $V_{MAX}$ ) and current ( $I_{MAX}$ ) specifications
- Calculate the voltage drop across the controller:

$$V_{DROP} = V_S - V_{MAX} \quad (V_S \text{ is the power supply voltage})$$

- Mark  $V_{DROP}$  on the X-axis, and extend a line upward
- Mark  $I_{MAX}$  on the Y-axis, and extend a line to the right until it intersects the  $V_{DROP}$  line
- On the X-axis, mark value of  $V_S$
- Extend a diagonal line from  $V_S$  to the intersection of the  $V_{DROP}$  and  $I_{MAX}$  lines; this is the Load Line
- If the Load Line crosses the Safe Operating Area line at any point, the configuration is not safe

If the SOA Calculator indicates the PLDxK-CH will be outside of the Safe Operating Area, the system must be changed so that less power is dissipated within the driver. See Wavelength Electronics Application Note [AN-LDTC01: The Principle of the Safe Operating Area](#) for information on shifting the Load Line.

After changing any of the operating parameters, recalculate the SOA to make sure the driver will operate safely. If you have questions, or run into difficulties calculating the SOA, contact Wavelength Electronics for assistance.

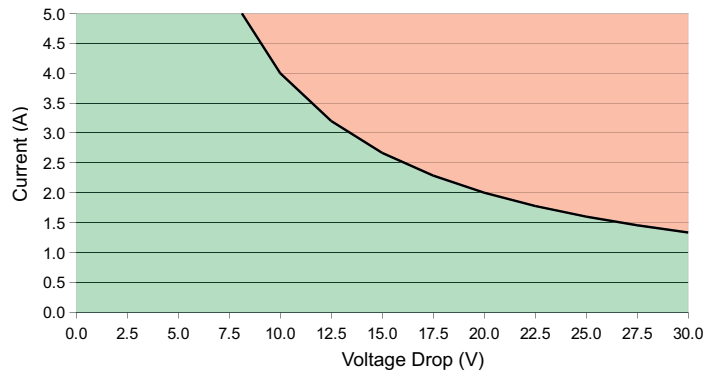

Figure 27. SOA for PLD5K-CH

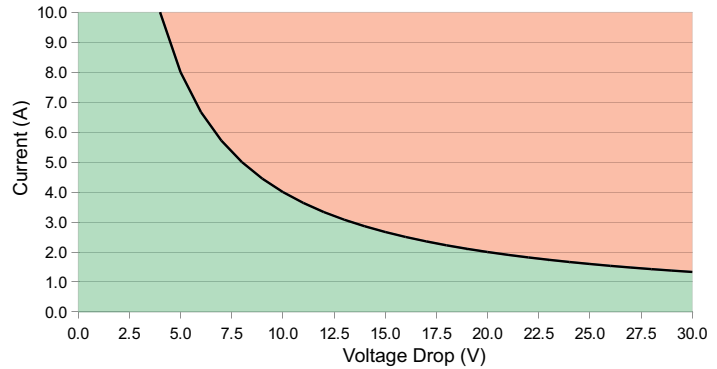

Figure 28. SOA for PLD10K-CH

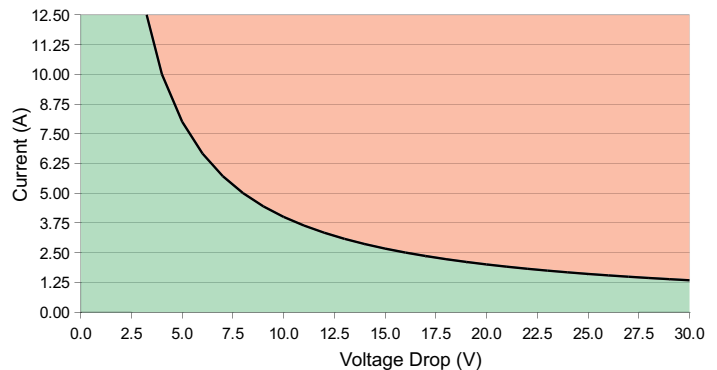

Figure 29. SOA for PLD12.5K-CH

## TROUBLESHOOTING

| PROBLEM  | POTENTIAL CAUSES   | SOLUTIONS  |
|--|--|--|
| Driver will not switch on                                  | Improperly configured power supply                           | Carefully check the wiring diagram according to <b>Table 3</b> .   |
| Output will not enable                                     | Remote Enable signal is not correct                          | Refer to the LD Enable specifications in <b>Table 1</b> and make sure your input enable signal is correct.   |
| Laser output power too low in Constant Current mode        | Laser current setpoint too low                               | Increase the setpoint either by adjusting the OUT ADJUST trimpot clockwise, or by increasing the signal voltage on ANALOG IN (pin J3:5).   |
|  | Laser current limit too low                                  | Refer to <b>page 13</b> for instructions on setting the laser driver current limit.  |
|  | Laser driver is compliance limited                           | Check the laser diode specifications to determine the forward voltage ( $V_f$ ). Make sure that the PLDxK-CH is not compliance limited. Refer to the Electrical Specifications table on <b>page 6</b> . If the driver is compliance limited, $V_{LD\ ANODE}$ may need to be increased.<br><br><b>Verify that the PLDxK-CH will be operating within the Safe Operating Area if <math>V_{LD\ ANODE}</math> is increased.</b> |
| Laser does not reach desired output in Constant Power mode | Current limit too low  | Check the laser diode datasheet to determine the approximate laser drive current at the desired optical power output level. Then verify that the current limit is set slightly higher than that. See <b>page 13</b> for instructions on setting the laser driver current limit.  |
|  | Photodiode feedback current is out of range for the PLDxK-CH | Refer to the laser diode datasheet to determine the approximate photodiode (PD) current at the desired output power level. If the PD current exceeds the PLDxK-CH PD current range, set the PD Range switch to High Range; see <b>page 13</b> .  |

## CABLING SPECIFICATIONS

### MONITOR CABLE -- WCB304; INCLUDED WITH PLDXK-CH

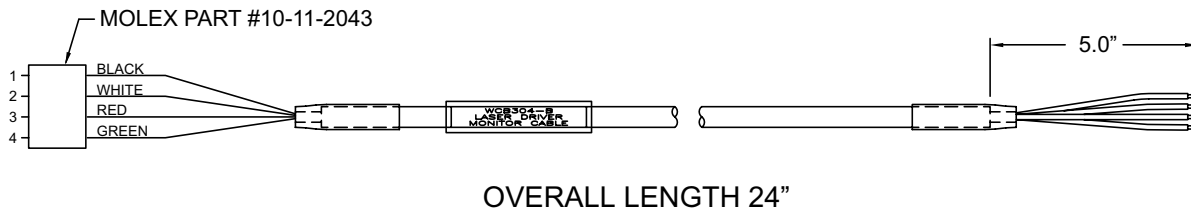

### I/O CABLE -- WCB305; INCLUDED WITH PLDXK-CH

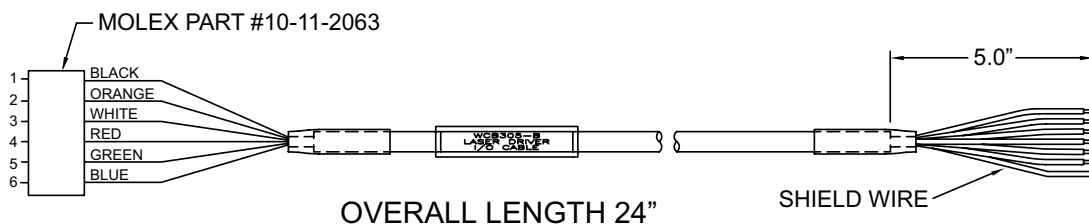

### PHOTODIODE CABLE -- WCB307; INCLUDED WITH PLDXK-CH



### POWER / LD CABLE -- WCB308; NOT INCLUDED WITH PLDXK-CH

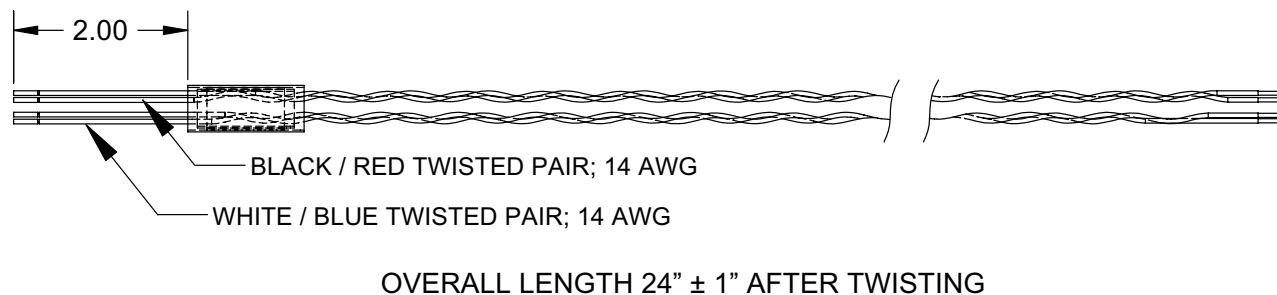

# MECHANICAL SPECIFICATIONS

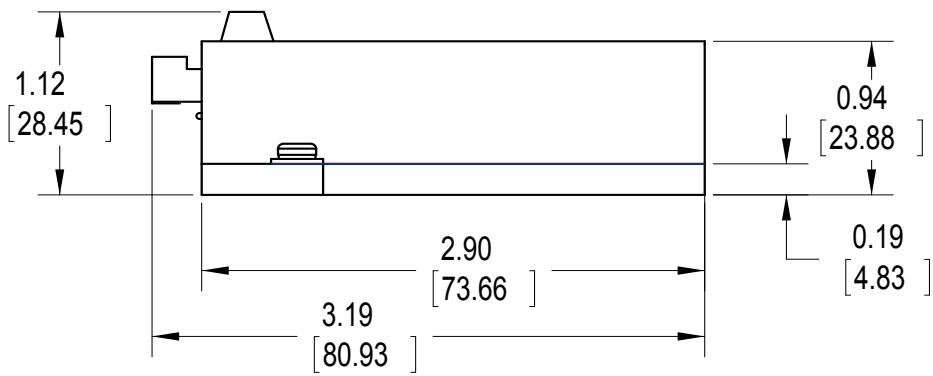
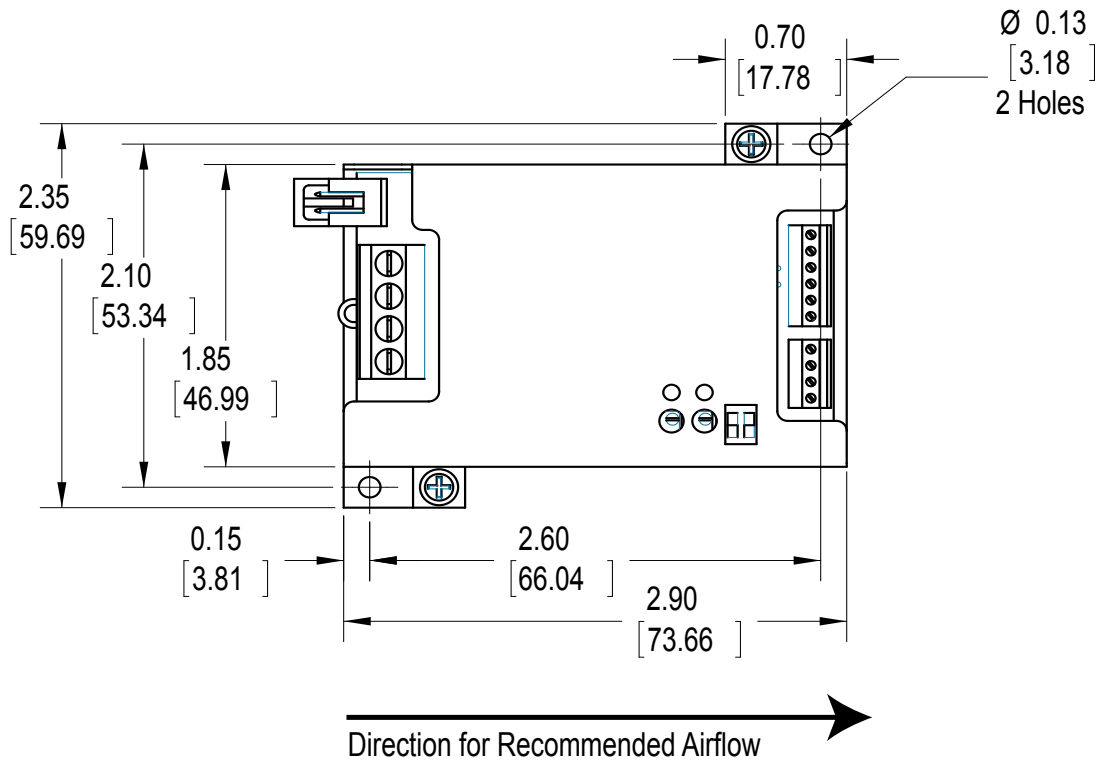

Figure 30. PLDxK-CH Driver Mechanical Dimensions

All Tolerances  $\pm 5\%$ ; units in inches [mm]

## CERTIFICATION AND WARRANTY

### CERTIFICATION

Wavelength Electronics, Inc. (Wavelength) certifies that this product met its published specifications at the time of shipment. Wavelength further certifies that its calibration measurements are traceable to the United States National Institute of Standards and Technology, to the extent allowed by that organization's calibration facilities, and to the calibration facilities of other International Standards Organization members.

### WARRANTY

This Wavelength product is warranted against defects in materials and workmanship for a period of one (1) year from date of shipment. During the warranty period, Wavelength will, at its option, either repair or replace products which prove to be defective.

### WARRANTY SERVICE

For warranty service or repair, this product must be returned to the factory. An RMA is required for products returned to Wavelength for warranty service. The Buyer shall prepay shipping charges to Wavelength and Wavelength shall pay shipping charges to return the product to the Buyer upon determination of defective materials or workmanship. However, the Buyer shall pay all shipping charges, duties, and taxes for products returned to Wavelength from another country.

### LIMITATIONS OF WARRANTY

The warranty shall not apply to defects resulting from improper use or misuse of the product or operation outside published specifications. No other warranty is expressed or implied. Wavelength specifically disclaims the implied warranties of merchantability and fitness for a particular purpose.

### EXCLUSIVE REMEDIES

The remedies provided herein are the Buyer's sole and exclusive remedies. Wavelength shall not be liable for any direct, indirect, special, incidental, or consequential damages, whether based on contract, tort, or any other legal theory.

### REVERSE ENGINEERING PROHIBITED

Buyer, End-User, or Third-Party Reseller are expressly prohibited from reverse engineering, decompiling, or disassembling this product.

### NOTICE

The information contained in this document is subject to change without notice. Wavelength will not be liable for errors contained herein or for incidental or consequential damages in connection with the furnishing, performance, or use of this material. No part of this document may be translated to another language without the prior written consent of Wavelength.

## SAFETY

There are no user-serviceable parts inside this product. Return the product to Wavelength Electronics for service and repair to ensure that safety features are maintained.

## LIFE SUPPORT POLICY

This important safety information applies to all Wavelength electrical and electronic products and accessories:

As a general policy, Wavelength Electronics, Inc. does not recommend the use of any of its products in life support applications where the failure or malfunction of the Wavelength product can be reasonably expected to cause failure of the life support device or to significantly affect its safety or effectiveness. Wavelength will not knowingly sell its products for use in such applications unless it receives written assurances satisfactory to Wavelength that the risks of injury or damage have been minimized, the customer assumes all such risks, and there is no product liability for Wavelength. Examples of devices considered to be life support devices are neonatal oxygen analyzers, nerve stimulators (for any use), auto-transfusion devices, blood pumps, defibrillators, arrhythmia detectors and alarms, pacemakers, hemodialysis systems, peritoneal dialysis systems, ventilators of all types, and infusion pumps as well as other devices designated as "critical" by the FDA. The above are representative examples only and are not intended to be conclusive or exclusive of any other life support device.

## REVISION HISTORY

DOCUMENT NUMBER: PLD10K-CH-00400

| REV. | DATE          | CHANGE                                |
|------|---------------|---------------------------------------|
| L    | November 2013 | Added CE mark and extended warranty   |
| M    | October 2015  | Added Disable Fall Time specification |
| N    | November 2015 | Removed relay short from 12.5K-CH     |
| O    | April 2020    | Updated noise section                 |



51 Evergreen Drive  
Bozeman, Montana 59715

406-587-4910 (tel)  
406-587-4911 (fax)



Sales & Tech Support  
[sales@teamwavelength.com](mailto:sales@teamwavelength.com)  
[techsupport@teamwavelength.com](mailto:techsupport@teamwavelength.com)