

SPECIFICATION OF THERMOELECTRIC MODULE AMS-127-1.0-0.8 (30x30) HT120 E L2 69K

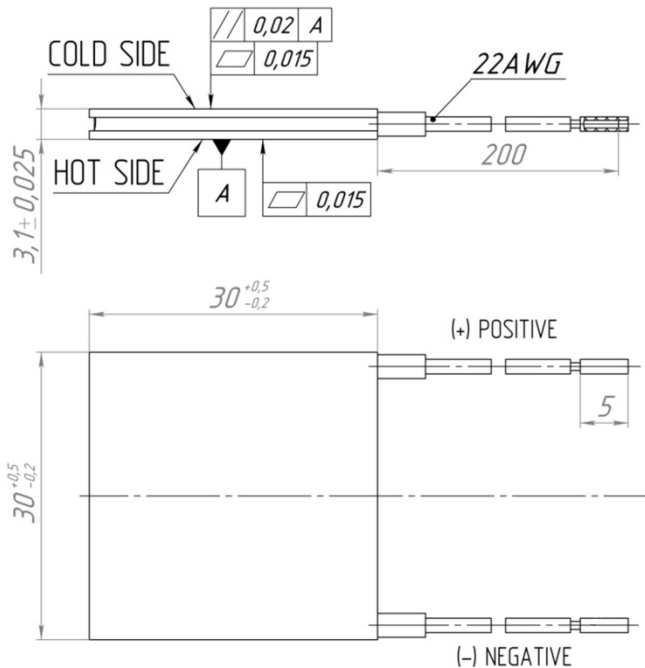

TEM with solder tabs, wires carefully sealed around solder tabs, 200mm wires, the TEM wires stripped and without tinning, the cut insulation remaining at the wire end.

Thermoelectric parameters	Unit	Value
I_{max}	Amps	5,8
U_{max}	Volts	15,7
ΔT_{max}	K	69
Q_{max}	Watts	56
R_{ac} (at 295 K), ±10%	Ohm	2,05
<i>All parameters except R_{ac} are given at Th=300 K</i>		

Option	Unit	Value
Ceramic material	-	Al₂O₃
Height tolerance	mm	± 0,025
Flatness	mm	0,015
Parallelism	mm	0,02
Sealant: epoxy	-	E
Max. processing temperature*	°C	130
Max. operating temperature	°C	120
Type of lead wires	-	22 AWG
ROHS compliance	-	Yes

* The maximum processing temperature influence on the module and must not exceed 2 minutes

Manufactured by:



6 Aerodromnaya street, Saint-Petersburg, 197348 Russia

