

## SSH66TE SERIES

### SHORT SWITCH FOR 3/4" NPT EXTERNAL FITTING



SSH66TE are externally mounted horizontal float switches with reduced length floats for applications where space is restricted. The float is of 316L Stainless Steel and the stem is of 304 Stainless Steel.

These devices are easily mounted, using 3/4" NPT, without needing internal access to the tank/vessel into which they are being fitted.

These are available with either 1 metre flying leads or with a DIN43650 connector.

The switch action may be reversed by mounting the device with the float able to move upwards away from the body, instead of the more normal downwards direction.

#### Features

- External Mount (3/4" NPT)
- Short Insertion Length
- Stainless Steel 316L Float
- Connection with DIN 43650 Plug or 100cm wires
- N/O or N/C switch action

## SPECIFICATIONS

### Technical

<b>Mounting Style</b>	External
<b>Mounting Thread</b>	3/4" NPT
<b>Float &amp; Stem Material</b>	316/304 grade SS
<b>Maximum Temperature</b>	120°C
<b>Maximum Pressure</b>	10 bar
<b>Float SG</b>	0.7
<b>Minimum Fluid SG</b>	0.75
<b>Cable Length - Standard</b>	100cm/Plug
<b>Cable Size</b>	17/0.10 - AWG22
<b>Cable Conductor Material</b>	Tinned copper
<b>Cable Sheath Material</b>	XLPE
<b>Cable Temperature Rating</b>	125°C
<b>Sealing Gasket</b>	Not supplied
<b>Tightening Torque for Fixing Nut</b>	2.0kg/cm

### Electrical

<b>Contact Form</b>		N/O or N/C
<b>Switching Power Max</b>	VA	1
<b>Switching Voltage AC Max</b>	V	24
<b>Switching Voltage DC Max</b>	V	24
<b>Switching Current Max</b>	A	0.1

All ratings are for resistive load only.

## STANDARD PARTS

	Stem Material	Float Material	Max Power	Leadouts
<b>SSH66TE34N100S</b>	304 SS	316 SS	1VA	100cm XLPE 17/0.1
<b>SSH66TE34NPS</b>	304 SS	316 SS	1VA	DIN connector

Custom versions can be made for particular applications. Please contact Sensata with your requirements.

## DIMENSIONS

All dimensions are in millimeters.

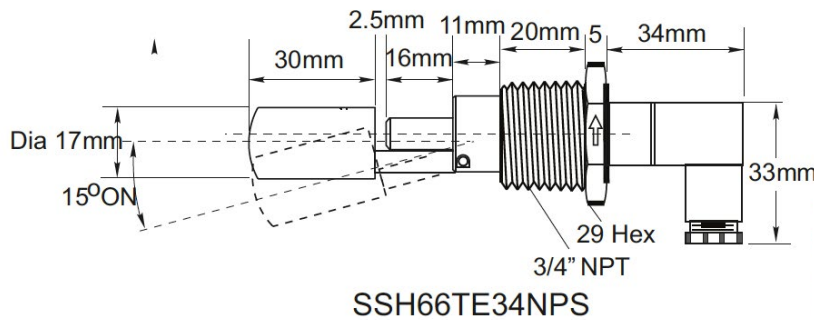
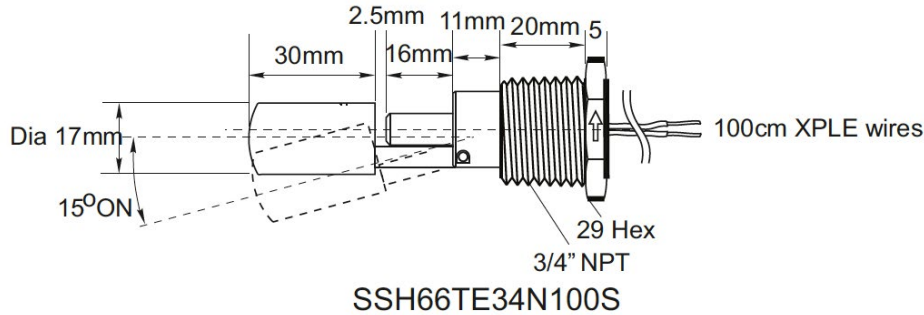

Distributor



**amstechnologies**  
where technologies meet solutions

info@amstechnologies.com  
www.amstechnologies-webshop.com

Contact us 

Sensata Technologies, Inc. ("Sensata") data sheets are solely intended to assist designers ("Buyers") who are developing systems that incorporate Sensata products (also referred to herein as "components"). Buyer understands and agrees that Buyer remains responsible for using its independent analysis, evaluation and judgment in designing Buyer's systems and products. Sensata data sheets have been created using standard laboratory conditions and engineering practices. Sensata has not conducted any testing other than that specifically described in the published documentation for a particular data sheet. Sensata may make corrections, enhancements, improvements and other changes to its data sheets or components without notice.

Buyers are authorized to use Sensata data sheets with the Sensata component(s) identified in each particular data sheet. HOWEVER, NO OTHER LICENSE, EXPRESS OR IMPLIED, BY ESTOPPEL OR OTHERWISE TO ANY OTHER SENSATA INTELLECTUAL PROPERTY RIGHT, AND NO LICENSE TO ANY THIRD PARTY TECHNOLOGY OR INTELLECTUAL PROPERTY RIGHT, IS GRANTED HEREIN. SENSATA DATA SHEETS ARE PROVIDED "AS IS". SENSATA MAKES NO WARRANTIES OR REPRESENTATIONS WITH REGARD TO THE DATA SHEETS OR USE OF THE DATA SHEETS, EXPRESS, IMPLIED OR STATUTORY, INCLUDING ACCURACY OR COMPLETENESS. SENSATA DISCLAIMS ANY WARRANTY OF TITLE AND ANY IMPLIED WARRANTIES OF MERCHANTABILITY, FITNESS FOR A PARTICULAR PURPOSE, QUIET ENJOYMENT, QUIET POSSESSION, AND NON-INFRINGEMENT OF ANY THIRD PARTY INTELLECTUAL PROPERTY RIGHTS WITH REGARD TO SENSATA DATA SHEETS OR USE THEREOF.

All products are sold subject to Sensata's terms and conditions of sale supplied at [www.sensata.com](http://www.sensata.com) SENSATA ASSUMES NO LIABILITY FOR APPLICATIONS ASSISTANCE OR THE DESIGN OF BUYERS' PRODUCTS. BUYER ACKNOWLEDGES AND AGREES THAT IT IS SOLELY RESPONSIBLE FOR COMPLIANCE WITH ALL LEGAL, REGULATORY AND SAFETY-RELATED REQUIREMENTS CONCERNING ITS PRODUCTS, AND ANY USE OF SENSATA COMPONENTS IN ITS APPLICATIONS, NOTWITHSTANDING ANY APPLICATIONS-RELATED INFORMATION OR SUPPORT THAT MAY BE PROVIDED BY SENSATA.

Mailing Address: Sensata Technologies, Inc., 529 Pleasant Street, Attleboro, MA 02703, USA.