

DATASHEET AND OPERATING GUIDE

HEATSINK BRACKET

For MULTI-HTSK and MULTI-HTSK-HI

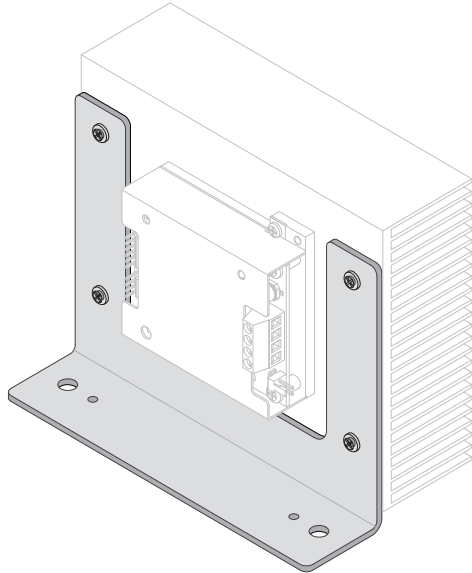

(MULTI-HTSK and controller are not included)

FEATURES AND BENEFITS

- Convenient and simple design
- Improves airflow to the heatsink
- Helps keep your optical bench organized
- Works with most Wavelength Electronics chassis mounted Laser Diode Drivers and Temperature Controllers

CONVENIENTLY MOUNT HEATSINKS

The heatsink bracket is compatible with both Wavelength Multi-Heatsinks, the MULTI-HTSK and the MULTI-HTSK-HI. These heatsinks are compatible with most Wavelength chassis-mounted temperature controllers and laser drivers. The bracket fits around the module, and the module can be installed without disassembling the bracket assembly.

IMPROVED HEAT DISSIPATION

The bracket mounts the heatsink in a vertical position, freeing space on your optical table. Convection is enhanced with the heatsink mounted vertically, so your Wavelength control module runs cooler at high powers. It's also a lot simpler to force additional airflow over the heatsink with a spare fan so you can use the heatsink to its full-rated capacity.

USED WITH

- MULTI-HTSK Multi-Product Heatsink
- MULTI-HTSK-HI Multi-Product Heatsink for >10 A

CONTENTS

	PAGE
SAFE OPERATING AREA	2
MOUNTING INSTRUCTIONS	2
MECHANICAL SPECIFICATIONS	3
CERTIFICATION AND WARRANTY	4

ORDERING INFORMATION

PART NO	DESCRIPTION
HTSK-BRKT	Heatsink Bracket for use with MULTI-HTSK and MULTI-HTSK-HI
MULTI-HTSK	Heatsink for < 10 A operation
MULTI-HTSK-HI	Heatsink for > 10 A operation



SAFE OPERATING AREA

Some Wavelength modules require heatsinking when operated above a particular power level, and forced airflow over the heatsink may be required at greater powers. The on-line SOA tool will help you to understand when these conditions apply to your situation.



IT IS IMPERATIVE THAT YOU VERIFY THE UNIT WILL OPERATE WITHIN THE INTERNAL HEAT DISSIPATION SAFE OPERATING AREA (SOA).

OPERATING THE CONTROLLER OUTSIDE THE SOA MAY DAMAGE OR DESTROY THE MODULE AND/OR LOADS.

To determine if the module is suitable for your application, if it will be operating in the safe range, or if forced airflow is required, consult the instructions for calculating the Safe Operating Area on-line at:

Laser Diode Drivers:

<http://www.teamwavelength.com/support/calculator/soa/soald.php>

Temperature Controllers:

<http://www.teamwavelength.com/support/calculator/soa/soatc.php>

If you have any questions about the Safe Operating Area calculator, call the factory for free and prompt technical assistance.

MOUNTING INSTRUCTIONS

The heatsink can be mounted to the bracket in two different ways, illustrated in the exploded views of **Figure 1** and **Figure 2**.

- If the heatsink is mounted on the side opposite the bracket foot, per **Figure 1**, the heatsink can be attached to the bracket before the bracket is mounted to the bench.
- If the heatsink is attached on the same side as the mounting foot, as in **Figure 2**, first mount the bracket to the benchtop before attaching the heatsink.

Then attach the heatsink to the bracket using 6-32 panhead screws (included) through four 0.140" holes (Ref C).

The bracket is mounted to the bench using 1/4-20 bolts (not included) through the two 0.281" holes (Ref A) or by other screws through the two 0.140" holes (Ref B).

Table 1. Which Modules are Compatible with the Bracket?

MODULE	HTSK-BRKT with MULTI-HTSK or MULTI-HTSK-HI
PLDxK-CH Series	Y
LDTCxx20 Series	Y
RHM5K-CH	Y
PTCkK-CH Series, -SL	Y
MPL Series	N
MPT Series	N

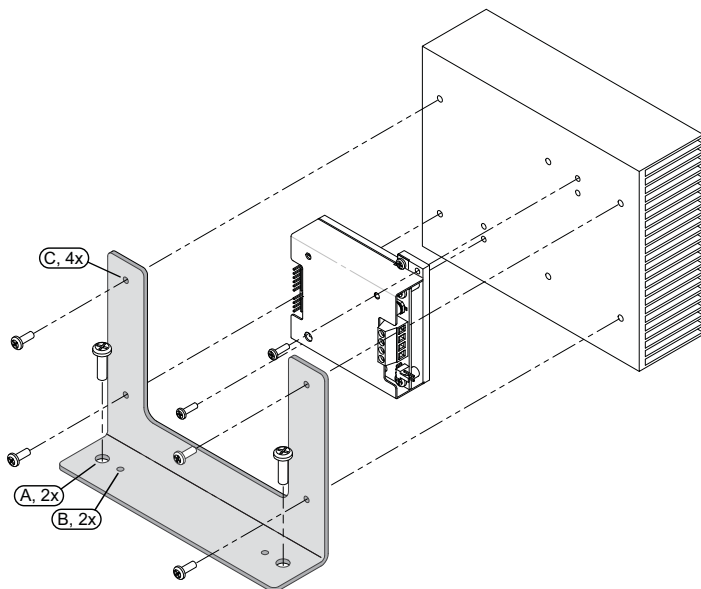

Figure 1. Mounting Option One

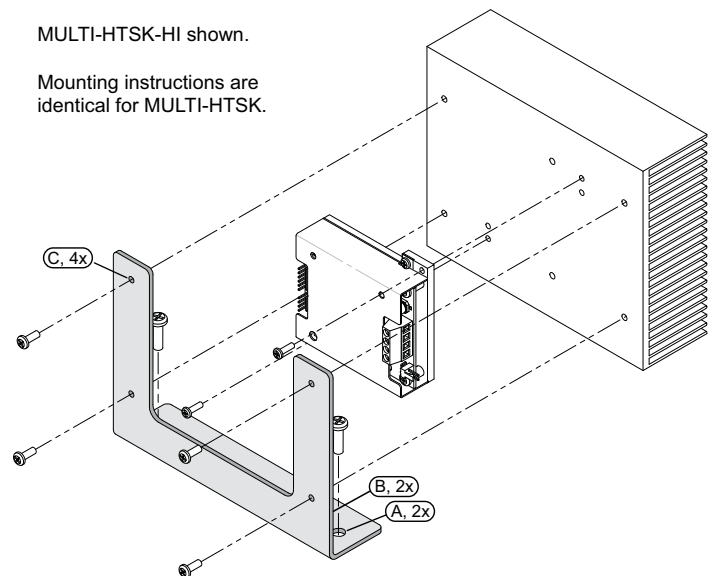
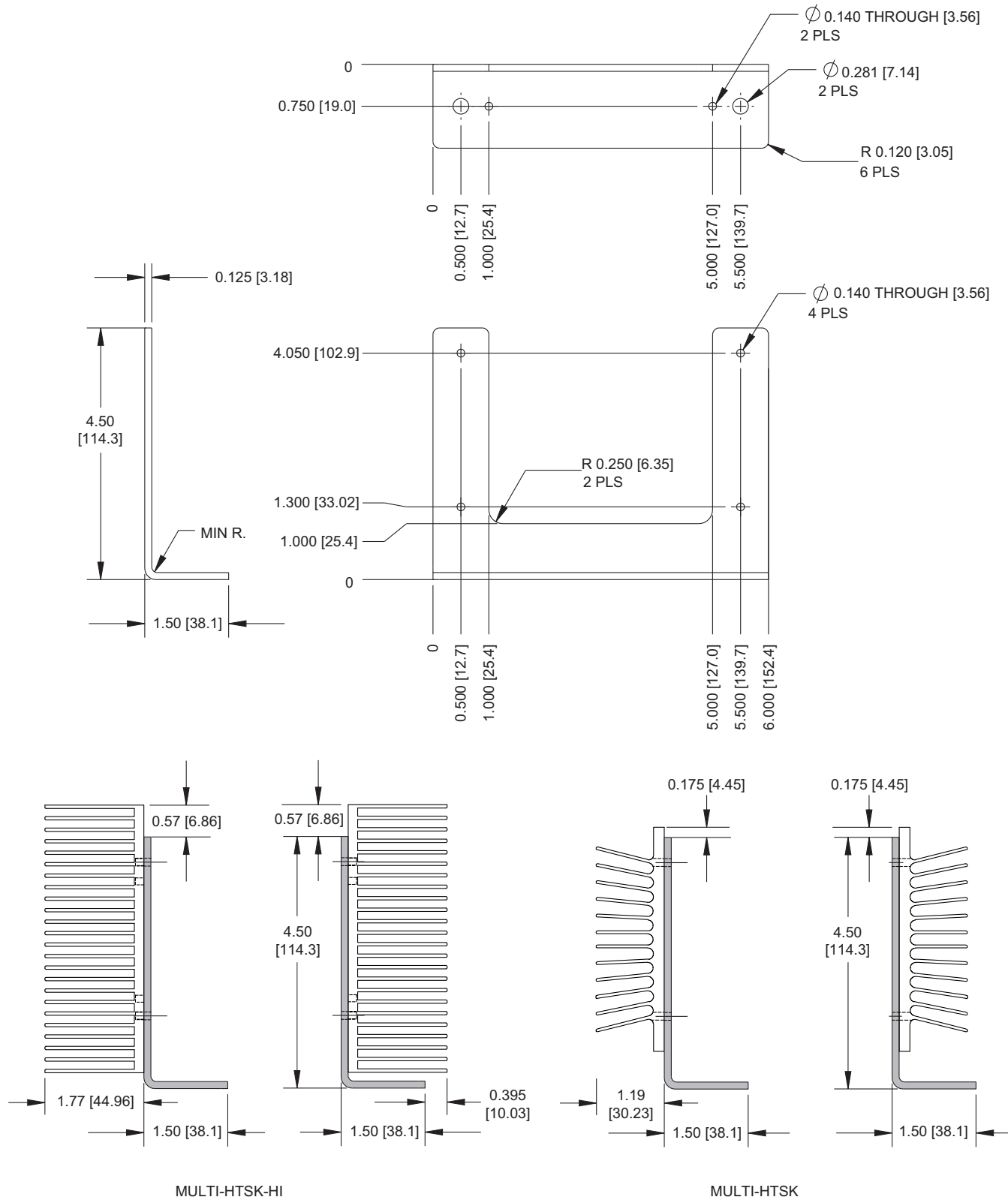

Figure 2. Mounting Option Two

The module is attached to the heatsink using screws that are included with the module.

MECHANICAL SPECIFICATIONS



DIMENSIONS IN INCHES [MM]
 ALL DIMENSIONS ARE ±0.01 [0.25]

Figure 3. Heatsink Bracket Dimensions (MULTI-HTSK and MULTI-HTSK-HI sold separately.)

CERTIFICATION AND WARRANTY

CERTIFICATION

Wavelength Electronics, Inc. (Wavelength) certifies that this product met its published specifications at the time of shipment. Wavelength further certifies that its calibration measurements are traceable to the United States National Institute of Standards and Technology, to the extent allowed by that organization's calibration facilities, and to the calibration facilities of other International Standards Organization members.

WARRANTY

This Wavelength product is warranted against defects in materials and workmanship for a period of one (1) year from date of shipment. During the warranty period, Wavelength will, at its option, either repair or replace products which prove to be defective.

WARRANTY SERVICE

For warranty service or repair, this product must be returned to the factory. An RMA is required for products returned to Wavelength for warranty service. The Buyer shall prepay shipping charges to Wavelength and Wavelength shall pay shipping charges to return the product to the Buyer upon determination of defective materials or workmanship. However, the Buyer shall pay all shipping charges, duties, and taxes for products returned to Wavelength from another country.

LIMITATIONS OF WARRANTY

The warranty shall not apply to defects resulting from improper use or misuse of the product or operation outside published specifications. No other warranty is expressed or implied. Wavelength specifically disclaims the implied warranties of merchantability and fitness for a particular purpose.

EXCLUSIVE REMEDIES

The remedies provided herein are the Buyer's sole and exclusive remedies. Wavelength shall not be liable for any direct, indirect, special, incidental, or consequential damages, whether based on contract, tort, or any other legal theory.

REVERSE ENGINEERING PROHIBITED

Buyer, End-User, or Third-Party Reseller are expressly prohibited from reverse engineering, decompiling, or disassembling this product.

NOTICE

The information contained in this document is subject to change without notice. Wavelength will not be liable for errors contained herein or for incidental or consequential damages in connection with the furnishing, performance, or use of this material. No part of this document may be translated to another language without the prior written consent of Wavelength.

LIFE SUPPORT POLICY

This important safety information applies to all Wavelength Electronics, Inc. electrical and electronic products and accessories:

As a general policy, Wavelength Electronics, Inc. does not recommend the use of any of its products in life support applications where the failure or malfunction of the Wavelength product can be reasonably expected to cause failure of the life support device or to significantly affect its safety or effectiveness. Wavelength will not knowingly sell its products for use in such applications unless it receives written assurances satisfactory to Wavelength that the risks of injury or damage have been minimized, the customer assumes all such risks, and there is no product liability for Wavelength. Examples of devices considered to be life support devices are neonatal oxygen analyzers, nerve stimulators (for any use), auto-transfusion devices, blood pumps, defibrillators, arrhythmia detectors and alarms, pacemakers, hemodialysis systems, peritoneal dialysis systems, ventilators of all types, and infusion pumps as well as other devices designated as "critical" by the FDA. The above are representative examples only and are not intended to be conclusive or exclusive of any other life support device.

REVISION HISTORY

DOCUMENT NUMBER: HTSK-BRKT00400

REV.	DATE	CHANGE
A	Apr 2012	Initial Release
B	October 2013	Extended Warranty

