

(Polarization Maintaining) Variable Optical Attenuator (PMVOA & VOA)

Description

(Polarization Maintaining) Variable Optical Attenuator is an useful tool for the optical components power adjustment and systems test.

Key Features

- High extinction ratio (For PMVOA)
- Wide attenuation range
- High precision
- Low original loss
- Compact size

Applications

- Fiber communication system test
- Optical passive component test

Mechanical Dimension

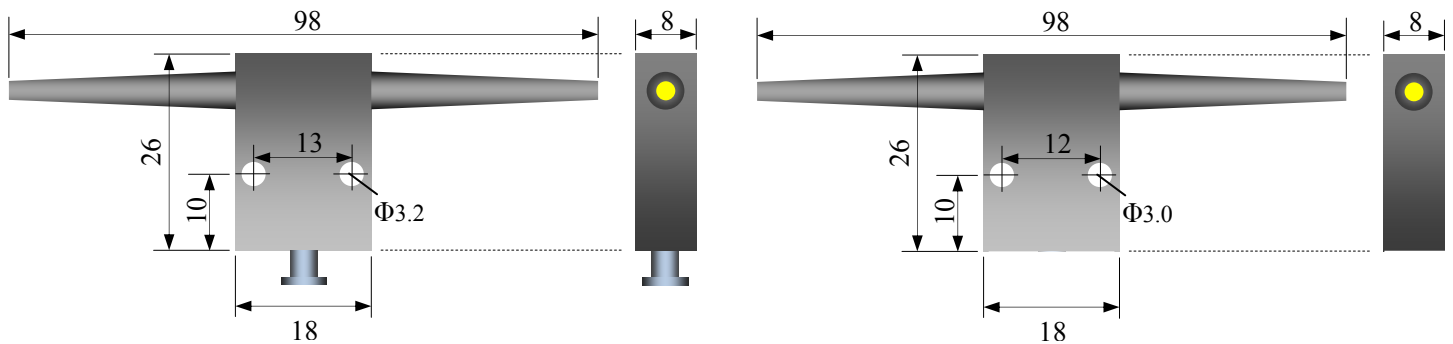

Manual Type



Screw Type

Specifications

Parameter \ Type	Unit	(Polarization Maintaining) Variable Optical Attenuator							
Center wavelength	nm	630	780	850	980	1064	1310	1550	850, 1310
Operating bandwidth	nm	±20	±20	±20	±20	±20	±40	±40	±40
Attenuation range	dB	1.5 ~50	1.3 ~50	1.0 ~50	1.0 ~50	0.8 ~50	0.6 ~50	0.6 ~50	0.8~40
Original loss	dB	≤1.5	≤1.3	≤1.0	≤1.0	≤0.8	≤0.6	≤0.6	≤0.8
ER (For PMVOA)	dB	≥18		≥20				/	
Return loss	dB	≥50							≥30
Fiber type (For VOA)	/	SM Fiber							50/125 or 62.5/125 multi-mode
Fiber type ((For PMVOA)	/	PM Panda Fiber							/
Handling power	mW	≤300				≤500			
Operating temperature	°C	0 ~ +70							
Storage temperature	°C	-40 ~ +85							
Dimensions	mm	26×18×8							

* IL is 0.3dB (1310~1550nm) or 0.50dB (980~1060) or 0.80dB (780~850) or 1.50dB (630) higher, RL is 5dB lower and ER (for PMVOA) is 2dB (1310~1550nm, 980~1060nm) or 3dB (780~850nm, 630nm) lower for each connector added. The default connector key is aligned to slow axis.

Ordering Information

(PM)VOA-X-X-XXXX-X-X-XX/XXX-XX*XX*XX

