

LASER TO FIBER COUPLER WITH RECEPTACLE (NON-CONTACT STYLE)

FEATURES:

- Low Cost
- High Power Handling
- Wide Range of Lenses
- Excellent Polarization Maintaining Capabilities
- Different Connector Receptacle Versions
- Wide Wavelength Ranges

APPLICATIONS:

- Laser Shows/Entertainment
- Spectroscopy
- Interferometric Sensors
- Fluorescence Measurements
- Medical, Pharmaceutical, and Chemical Sensors
- OEM Laser Systems

SPECIFICATIONS:

- Coupling Efficiency: Typically >60% into singlemode or polarization maintaining fibers, >80% for multimode fibers
- Backreflection Levels: Typically -14dB with standard connectors
Typically <-60dB with angled connectors
- Available Wavelengths: 180 - 2000nm
- Polarization Extinction Ratios: Typically >20dB
25, 30dB versions are also available
- Power Handling: >1 Watt CW for GRIN lenses,
>10 Watt CW for aspheric lenses
>5 Watts CW for achromats
>100 Watts CW for fused silica or sapphire plano-convex and biconvex lenses

PRODUCT DESCRIPTION:

In non-contact style source couplers, an air gap exists between the fiber and the lens. This design is more flexible, allowing a wide range of lens types and focal lengths to be used. The distance between the fiber and the lens can be adjusted to compensate the changes in the source wavelengths or to intentionally defocus the laser beam to prevent arcing in high power laser to multimode fiber applications. Couplers using GRIN lenses, achromats, aspheres, fused silica, plano-convex, and biconvex lenses have all been made utilizing this design.

Non-contact style couplers can handle input powers of up to 100W CW, and even higher energies from pulsed sources. They are best suited for applications where either the input energy is higher than 400mW, or when more than one wavelength is to be coupled into the fiber, or for input beams that have unusually large beam diameters or divergence angles. They also have superior

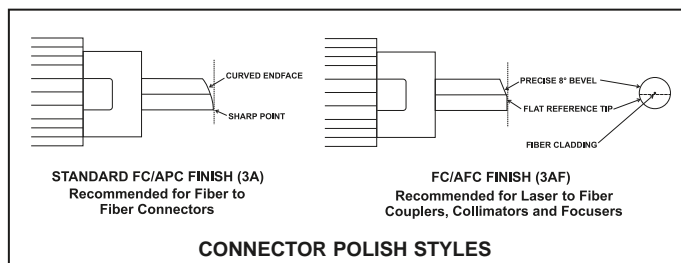

polarization maintaining capabilities compared to physical contact style couplers. However because of the air gap between the fiber and the lens, the backreflection level for the endface of the fiber is about -14dB. This can be reduced to -40dB to -60dB by slant polishing both fiber ends to deflect the backreflected signal.

There is a significant variation in the endface geometries of angled PC (APC) connectors. This effects the spacing between the endface of the fiber and the lens. To minimize this variation, OZ Optics offers an angled flat (AFC) connector. This connector features a beveled endface where the fiber itself is angled but the ferrule tip is flat. This geometry provides optimum repeatability between connections.

For users of SMA connectors, please note that standard SMA connectors and receptacles are constructed to rather loose tolerances, leading to poor repeatability. For core diameters 100 microns or smaller, we recommend using SMA connectors with Zirconia ferrules and receptacles with Zirconia sleeves. This will give maximum repeatability. Better still, consider using FC connectors instead.

ORDERING INFORMATION:

HPUC-2X-W-F-f-LH

Receptacle Code:

3 for FC, Super FC/PC, Ultra FC/PC
 3A for Angled FC/PC
 3AF for Flat Angled FC
 5 for SMA 905
 8 for AT&T-ST
 8U for Ultra AT&T-ST
 SC for SC

See Table 6 of the *Standard Tables* for other connectors

http://www.ozoptics.com/ALLNEW_PDF/DTS0079.pdf

Wavelength: Specify in nanometers
 (Example: 1550 for 1550nm)

Laser Head Adaptor

1 for 1"-32TPI Male Threaded Adapter
 2 for Disk Adapter with 4 holes on 1" square
 11 for Post Mount Adapter

See Table 8 of the *Standard Tables* for other adaptors

http://www.ozoptics.com/ALLNEW_PDF/DTS0079.pdf

Lens ID: See *Lens Selection Guide 2* for Non - Contact couplers with receptacles in the *Laser to Fiber Coupler Application Notes*
http://www.ozoptics.com/ALLNEW_PDF/DTS0108.pdf
http://www.ozoptics.com/ALLNEW_PDF/APN0004.pdf

Fiber Type:

M for Multimode
 S for Singlemode
 P for Polarization Maintaining

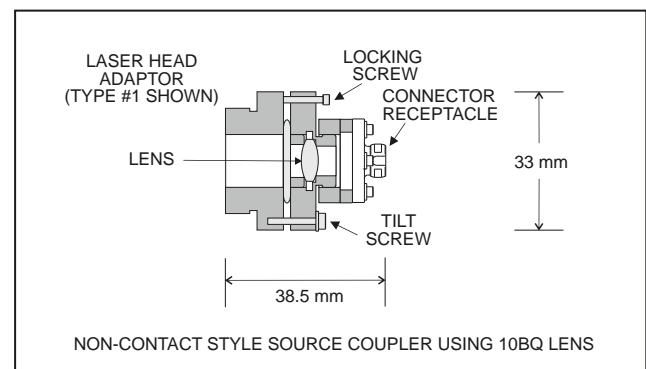
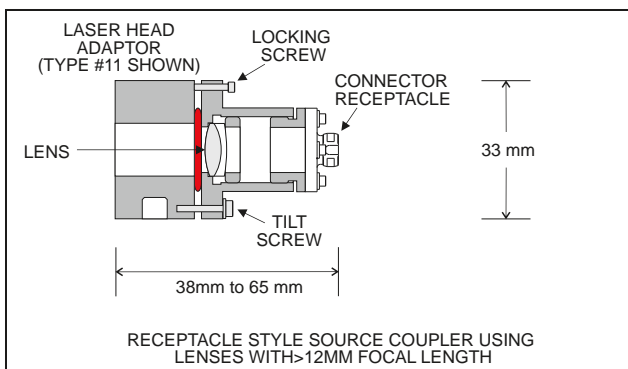
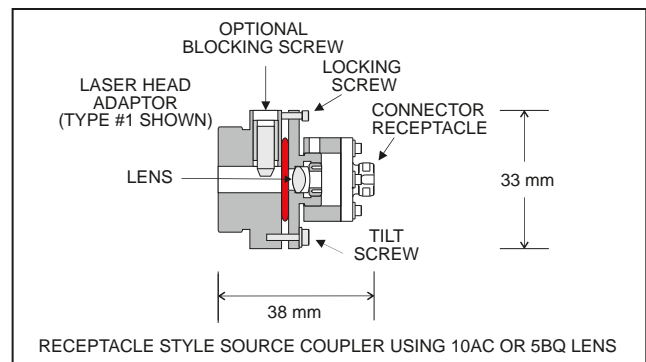
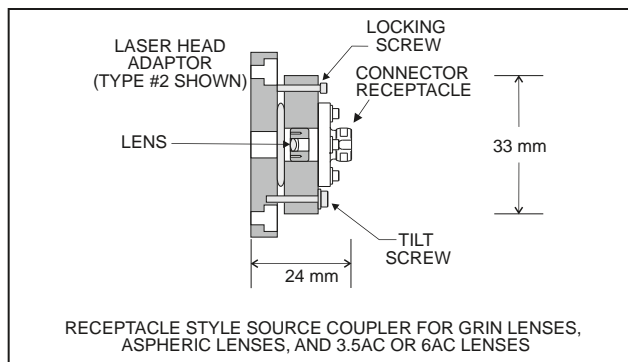

STANDARD COUPLERS:

OZ OPTICS PART NUMBER	BAR CODE NUMBER	OZ OPTICS PART NUMBER	BAR CODE NUMBER
HPUC-23-400/700-S-3.5AC-1	3793	HPUC-23-400/700-S-3.5AC-2	3802
HPUC-23-400/700-S-6AC-1	3794	HPUC-23-400/700-S-6AC-2	3803
HPUC-23-400/700-S-10AC-1	3798	HPUC-23-400/700-S-10AC-2	3806
HPUC-23AF-400/700-S-3.5AC-1	3796	HPUC-23AF-400/700-S-3.5AC-2	3082
HPUC-23AF-400/700-S-6AC-1	3797	HPUC-23AF-400/700-S-6AC-2	3805
HPUC-23AF-400/700-S-10AC-1	3795	HPUC-23AF-400/700-S-10AC-2	3804
HPUC-23-325-S-5BQ-1	3799	HPUC-23-325-S-5BQ-2	3807
HPUC-23-325-S-10BQ-1	3800	HPUC-23-325-S-10BQ-2	3808

NOTE: To determine the best laser to fiber source coupler for your application please complete a *Laser to Fiber Delivery System Questionnaire* http://www.ozoptics.com/ALLNEW_PDF/QTR0002.pdf. OZ Optics will then recommend a coupler based on your response.

For more standard parts, please see our online catalog <http://shop.ozoptics.com>

Lens Selection Guide for Laser to Fiber Couplers can be found: http://www.ozoptics.com/ALLNEW_PDF/DTS0108.pdf

Laser Head Adapter Drawings can be found: http://www.ozoptics.com/ALLNEW_PDF/DWG0001.pdf

Standard Tables can be found: http://www.ozoptics.com/ALLNEW_PDF/DTS0079.pdf

Laser to Fiber Source Couplers - Application Note can be found: http://www.ozoptics.com/ALLNEW_PDF/APN0004.pdf

ALIGNMENT KITS:

The following alignment kits are recommended for receptacle style laser to fiber couplers:

Connector Type	Wavelength 400–2000nm	Wavelength 180–700nm
NTT-FC/PC, Super FC/PC or Ultra FC/PC	START-03-USB-IRVIS	START-03-USB-UVVIS
FC/APC Angle polish	START-03A-USB-IRVIS	START-03A-USB-UVVIS
FC/AFC Angled flat	START-03AF-USB-IRVIS	START-03AF-USB-UVVIS
Adjustable FC/PC	START-0A3-USB-IRVIS	START-0A3-USB-UVVIS
Adjustable FC/APC	START-0A3A-USB-IRVIS	START-0A3A-USB-UVVIS
Adjustable FC/PC for High Power	START-0A3HP-USB-IRVIS	START-0A3HP-USB-UVVIS
Adjustable FC/APC for High Power	START-0A3AHP-USB-IRVIS	START-0A3AHP-USB-UVVIS
SMA 905	START-05-USB-IRVIS	START-05-USB-UVVIS
SMA 906	START-06-USB-IRVIS	START-06-USB-UVVIS
AT&T-ST	START-08-USB-IRVIS	START-08-USB-UVVIS
SC	START-0SC-USB-IRVIS	START-0SC-USB-UVVIS
Angled SC	START-0SCA-USB-IRVIS	START-0SCA-USB-UVVIS

POLARIZATION ALIGNMENT TOOL:

The following polarization alignment tools are recommended for receptacle style laser to fiber couplers:

Bar Code	Wavelength	Part #
45741	360–410nm	POL-ALIGN-360/410
13517	400–700nm	POL-ALIGN-400/700
21177	800–1600nm	POL-ALIGN-800/1600

TORQUE SCREWDRIVER:

Handheld torque wrench set to 1 in/lb with a 0.050" ball driver on the output.

Bar Code	Part #
21092	TORQUE-WRENCH-1-0.050BD