

Distributor



**amSTECHNOLOGIES**  
where technologies meet solutions

info@amstechnologies.com  
www.amstechnologies-webshop.com

**Contact us** 

## Online Sensor Head with VRS

### T-Gauge® HXC51yn

The HXC51yn\* Online Sensor Head adds functionality to the standard online sensor head (HXC50yn) with a virtual reference surface (VRS). Reflection measurement of thickness, multi-layer thickness, basis weight, and density are easily acquired. The VRS enables non-contact, calibrationless caliper thickness measurement as well as basis weight and density without reducing the open separation between the sensor and the product.

The transmitter and receiver are securely mounted inside the sealed metal housing. The umbilical for the transceiver, containing the electrical and optical connections, is constructed with high flex rated electrical cable to allow for continuous scanning.

When connected to a T-Ray® 5000 Control Unit, the HXC51yn will provide excellent waveform response, capable of providing detailed reflection measurement of layered surfaces.

\*  $y = 4$  for 75mm lens and 5 for 150mm lens,  $n = 1$  for a Type 1 (HP) transmitter and 2 for a Type 2 (GP) transmitter.

### APPLICATIONS

- Industrial process control: commercial roofing; foam density; paint thickness; plastic extrusion; asphalt shingles
- Nondestructive materials inspection: aircraft; packaged goods; radome inspection; spacecraft; pipeline repairs
- Converting applications: paper coating; multilayer films; tire



### KEY FEATURES

- Full transceiver functionality
- Collinear design
- Low cost plastic lens
- Hardened case for industrial environment
- Use to measure layer thickness
- Use to produce scanned images
- Single high flex umbilical
- Variety of focal lengths available
- Capable of being cleaned
- Supports VRS functionality

### BENEFITS

- No need for separate transmitter and receiver
- Simple orientation to target
- Inexpensive to replace if damaged
- Extended lifetime
- Replace multiple sensors
- Compatible with various motion options
- Long umbilical life in scanner or robot
- Improve product quality by optimizing production
- Tolerant to dirt and dust in the factory
- Increases product gap for density measurements

| Parameter                     | Specification      | Units | Comments                        |
|-------------------------------|--------------------|-------|---------------------------------|
| Polarization Extinction Ratio | > 20:1             |       | Horizontal                      |
| Available Lens Focal Length   | 25, 75, 150, coll. | mm    | Other lens available on request |
| Beam Diameter                 | 38                 | mm    |                                 |
| Mounting Hardware             | 1/4 - 20           |       | Threaded mounting holes         |
| Operating Temperature Range   | 0 - 50             | °C    | 20 - 90% RH non-condensing      |
| Size (W x H x D)              | 128 x 66 x 178     | mm    |                                 |
| Weight                        | 1.8                | kg    | With VRS                        |

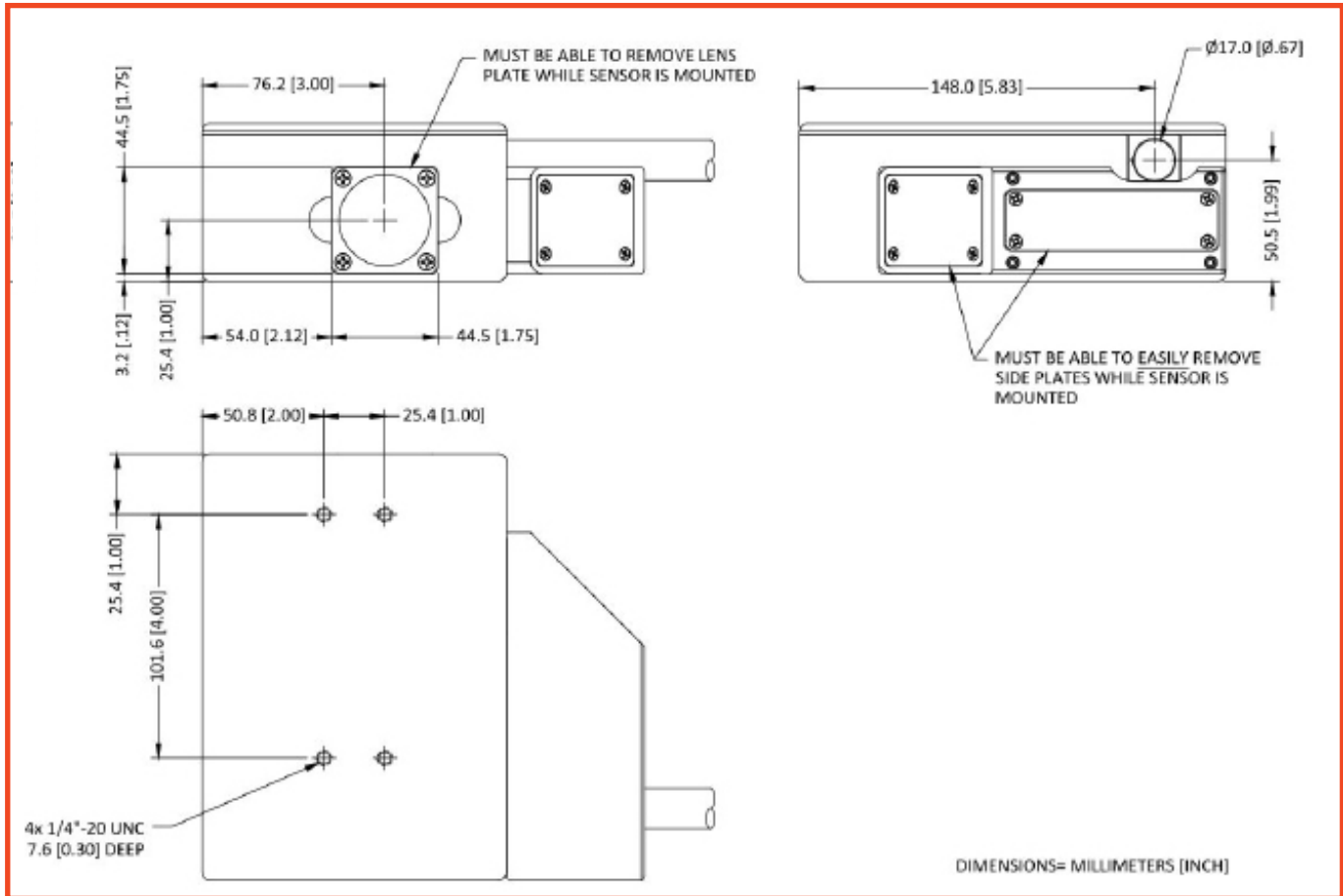

## ORDERING INFORMATION

### Included

- HDPE Lens (1, 3, or 6 in)

### Typical Configuration

- Terahertz Controller
- Umbilical (5,10, or 30 m)
- T-Ray® Basic and T-Gauge® Software

Distributor



info@amstechnologies.com  
www.amstechnologies-webshop.com

**Contact us** 

where technologies meet solutions

### Industry Leading Regulatory Compliance

The T-Ray 5000 intelligent TCU has been certified by Underwriters Laboratories has received the CE mark, is fully compliant with FDA CDRH laser safety regulations, and has been tested to meet FCC part 18 regulations.

