

## C30737LH-300-7XN Series

# Low Capacitance Silicon Avalanche Photodiode in Leadless Ceramic Carrier SMT Package for High Volume Laser Meter and Range Finding Applications

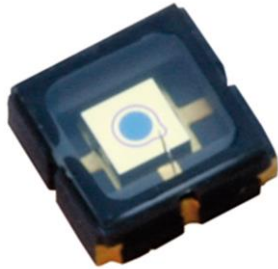

*The C30737LH-300-7XN Series from Excelitas Technologies is available in an LLC SMD package that comes with clear glass or built-in 635 nm, 650 nm, or 905 nm filter window options.*

Excelitas Technologies' C30737LH-300-7XN Series employs a 300  $\mu\text{m}$  active area silicon avalanche photodiode (APD) providing high responsivity between 500 nm and 1000 nm, as well as extremely fast rise times at all wavelengths with a frequency response up to  $>1$  GHz. Its size allows for an easy optical assembly at the same time providing a very low capacitance  $<1$  pF.

This APD is available in leadless, ceramic-carrier (LCC) SMD package that comes with clear glass or built-in 635 nm, 650 nm, or 905 nm filter window options. The device is available in tape-and-reel packing format which allows for SMT-compatible, RoHS-compliant reflow soldering.

It is an ideal APD device for high volume, cost-effective commercial distance-meter, range-finder, and high-speed, 3D laser scanning (LIDAR) applications.

### Key Features

- Low capacitance,  $<1\text{pF}$ , for high speed, large bandwidth applications
- Surface mount – tape and reel compatible
- High gain at low bias voltage
- Low noise
- Built-in filter windows
- RoHS-compliant

### Applications

- Laser meters for e.g. 635 nm or 650 nm
- 905 nm range finding devices
- Speed gun
- Area scanners for safety, surveillance, automatic door openers
- Gesture recognition applications
- Optical communication
- Industrial and consumer 3D laser scanning



Distributor



AZPECT  
part of

**amstechnologies**

where technologies meet solutions

nordics@amstechnologies.com  
azpect.amstechnologies.com

**Contact us** 

**EXCELITAS**<sup>®</sup>  
TECHNOLOGIES

Table 1. Electrical Characteristics at T<sub>A</sub> = 22 °C; at operating voltage-V<sub>op</sub>

C30737LH-300-7XN*						
(*X= filter #, see table 2 below)						
Parameters	Symbol	Unit	Min	Typ	Max	Comments
Diameter of active area	Φ	um		300		
Breakdown voltage	V <sub>br</sub>	Volts	110	130	165	
Operating voltage	V <sub>op</sub>	Volts	95	120	155	@ S=35A/W, 635nm
Gain	M	-	-	100	-	M=1@V <sub>r</sub> =10V
Temperature Coefficient	T <sub>coeff</sub>	V/°C		0.6		
Responsivity	S	A/W	-	35	-	@ 635nm & V <sub>op</sub>
Dark current	I <sub>d</sub>	nA	-	1	-	@ V <sub>op</sub>
Noise current	I <sub>n</sub>	pA/√Hz	-	0.2	-	@ V <sub>op</sub>
Capacitance	C	pF	0.6	0.7	0.8	
Bandwidth	f <sub>c</sub>	GHz	-	0.7	-	
Operating temperature		°C	-20		+60	
Storage temperature		°C	-40		+100	

Table 2. Filter Options and Transmission Characteristics

Filter #	0	1	2	3	
Nominal center wavelength	-	635 nm <sup>note 1</sup>	905 nm <sup>note 2</sup>	650 nm <sup>note 3</sup>	Transmission ≥ 85%
Transmission window	clear glass	623...652 nm		638...669 nm	Transmission ≥ 85%
50% cut-on wavelength	-	606...617 nm	870...890 nm	622...634 nm	
50% cut-off wavelength	-	657...669 nm	929...949 nm	673...685 nm	
Average transmission from 300 nm to bandpass region	-	<1% @ <593 nm	<1% @ <850 nm	<1% @ <608 nm	
Average transmission from bandpass region to 1100 nm	-	<1% @ >682 nm	<1% @ >979 nm	<1% @ >699 nm	
Wavelength drift	-	<+0.5 nm/°C	<+0.5 nm/°C	<+0.5 nm/°C	for range - 10°C...+50°C
Typical window thickness	0.3 mm	0.3 mm	0.3 mm	0.3 mm	Material: Borosilicate

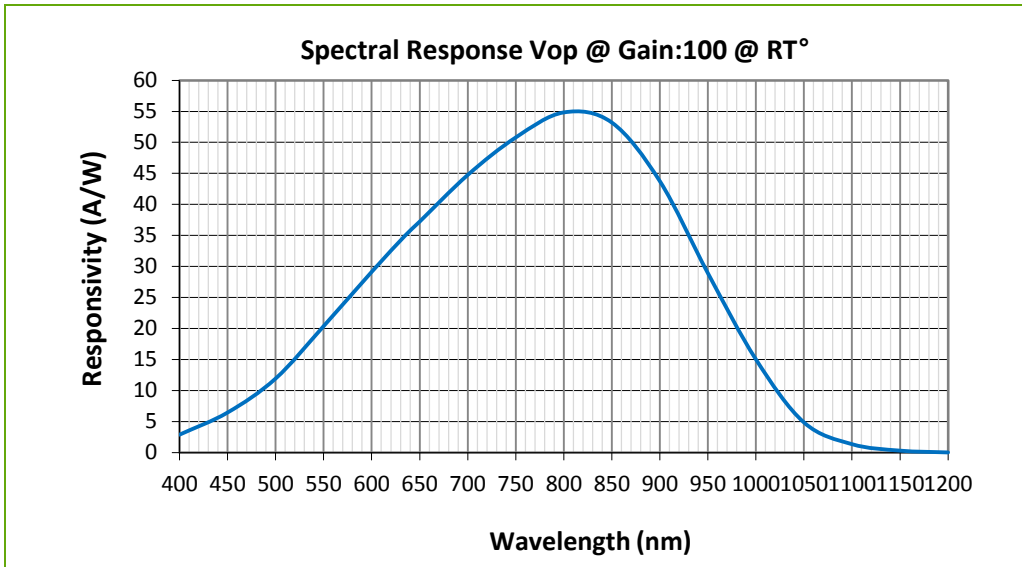

**Figure 1**  
Typical spectral response curve (for clear glass window without filter)

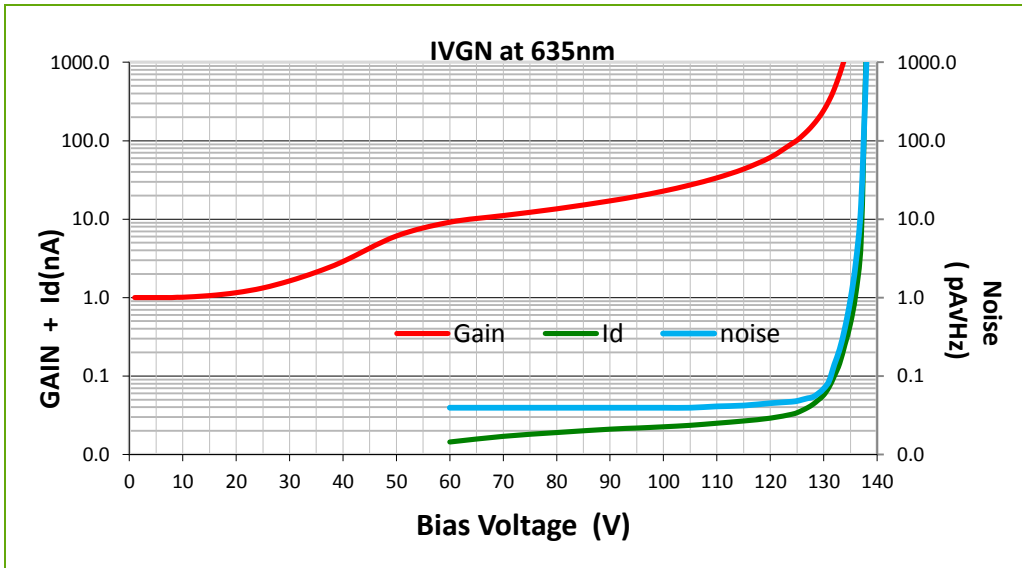

**Figure 2**  
Typical Gain, dark current and noise current vs. Bias voltage

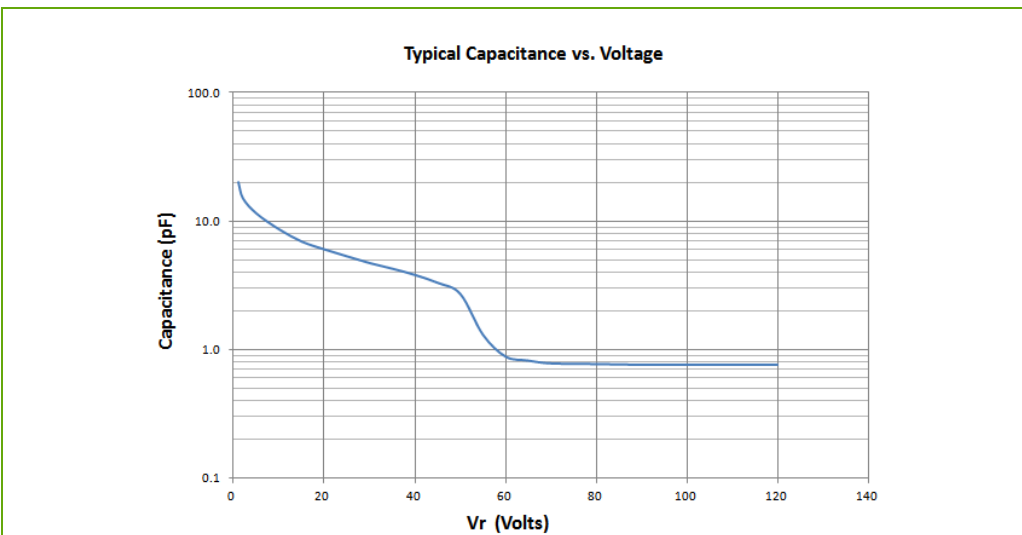

**Figure 3**  
Typical Capacitance vs. Bias Voltage

## C30737LH-300-7XN Series

### 300 $\mu\text{m}$ , low capacitance APD in LLC Package

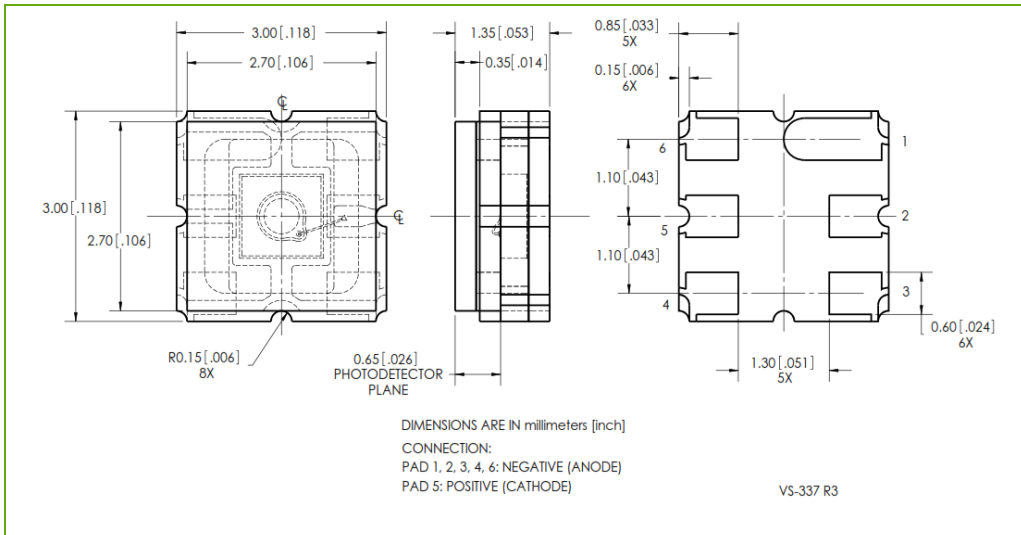

**Figure 4**  
Leadless ceramic carrier (LCC) package. Dimensions in mm [inches]

#### Tape-and-Reel Shipping Pack Option

The C30737LH-300-7XN (Leadless ceramic carrier (LCC) package) series are offered in the tape-and-reel shipping pack option for quantities of 3000 units per reel (**part number: C30737LH-300-7XNTR**). This packing option should be indicated at the time of order placement.

#### RoHS Compliance

This series of APDs are designed and built to be fully compliant with the European Union Directive 2011/65/EU – Restriction of the use of certain Hazardous Substances (RoHS) in Electrical and Electronic equipment.



#### Warranty

A standard 12-month warranty following shipment applies.

#### About Excelitas Technologies

Excelitas Technologies is a global technology leader focused on delivering innovative, customized solutions to meet the lighting, detection and other high-performance technology needs of OEM customers.

From aerospace and defense to analytical instrumentation, clinical diagnostics, medical, industrial, and safety and security applications, Excelitas Technologies is committed to enabling our customers' success in their specialty end-markets through innovation and commitment to delivering the highest quality solutions. Excelitas Technologies has approximately 5,000 employees in North America, Europe and Asia, serving customers across the world.

Distributor



nordics@amstechnologies.com  
aspect.amstechnologies.com

**amSTECHNOLOGIES**  
where technologies meet solutions

**Contact us** 