

SPECIFICATION OF THERMOELECTRIC MODULE AMS-199-1.4-1.5-(40x40) HT120 E L2 70K

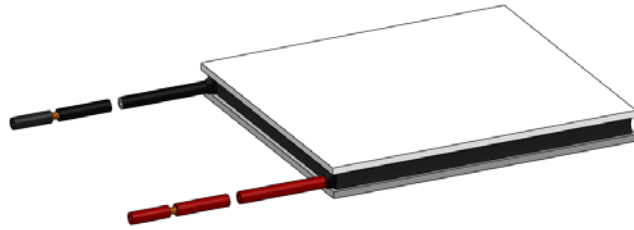

Thermoelectric parameters	Unit	Value
I_{max}	Amps	6,1
U_{max}	Volts	24,9
ΔT_{max}	K	70
Q_{max}	Watts	94
R_{ac} (at 295 K), ±10%	Ohm	3,2
<i>All parameters except R_{ac} are given at Th=300 K</i>		

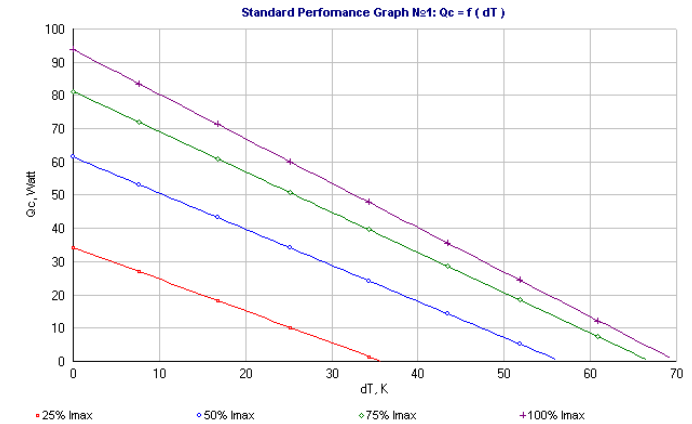

Option	Unit	Value
Ceramic material	-	Al₂O₃
Height tolerance	mm	± 0,025
Flatness	mm	0,015
Parallelism	mm	0,02
Sealant: epoxy	-	E
Max. processing temperature*	°C	130
Max. operating temperature	°C	120
Type of lead wires	-	22 AWG
ROHS compliance	-	Yes

* The maximum processing temperature influence on the module and must not exceed 2 minutes

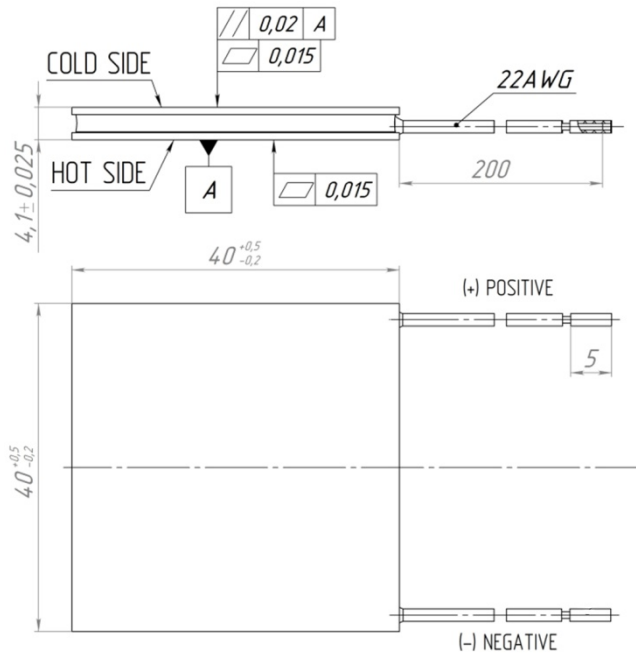
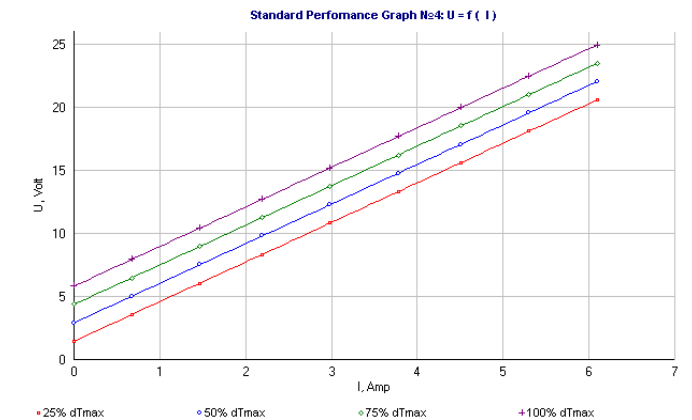

TEM no solder tabs, 200mm wires, the TEM wires stripped and without tinning, the cut insulation remaining at the wire end.

Manufactured by:



6 Aerodromnaya street, Saint-Petersburg, 197348 Russia