

cold plates

reliably cooling power electronics, lasers and batteries

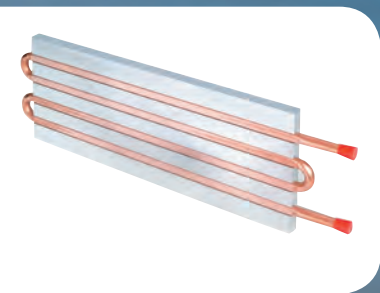

- ❄ cold plates for 62 mm power semiconductor modules
- ❄ cold plates for PrimePack 3 power semiconductor modules
- ❄ cold plates for $140 \times 190 \text{ mm}^2$ power semiconductor modules
- ❄ general purpose cold plates
- ❄ light weight cold plates for low to medium power densities

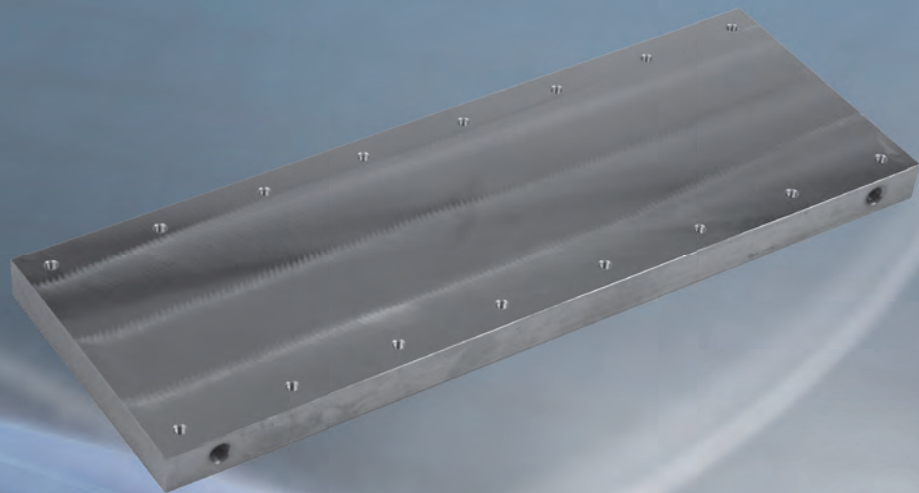

THERMAL
MANAGEMENT

AMS Technologies – where technologies meet solutions

AMS Technologies is a leading solution provider and distributor of high-tech, leading-edge components, systems and equipment, with more than 35 years of experience to date and currently serving more than 2000 European customers.

We are the specialists in both components and complete solutions for Optical Technology, Thermal Management and Power Technology fields, with access to and long standing relationships with the most advanced manufacturers in each of those fields. Drawing extensively on our experience in each of these differing technologies, and coupling this with our broad system-level competence, we are able to offer seamless and comprehensive solutions incorporating complementary aspects from all three key technology fields.

With an appropriate technical education, an element of entrepreneurial spirit and many years of design and consultancy expertise, our sales engineers can rapidly comprehend system requirements and provide you the customer with a solution that goes way beyond a simple understanding of our product datasheets. We take active involvement in the design cycle, defining and re-defining your specifications, and leading in many

cases to highly specific, customized products and solutions. Helping you to effectively outsource your production line, we can even provide you with the necessary leading turnkey contract manufacturing services in our key competency fields.

AMS Technologies has been delivering solutions into a variety of high-tech markets, including renewable energies, medical, defence & aerospace, research & scientific and various other industrial segments. Our customer base consists of Europe's largest leading technology corporations, a network of universities and research institutes as well as the most promising start-ups.

We thrive by working in a 'customer first' environment. Our pan-European customers are serviced from a network of local offices in Germany, the UK, France, Italy, Spain, Poland and Sweden, with a focused operations and logistics centre located in Munich, Germany.

Our commitment: Identifying the best solution for your project enabling you to become your customers' first choice!

Your AMS Technologies team



- Optical Technologies
- Power Technologies
- Thermal Management

cold plates – reliably cooling power electronics, lasers & batteries

For high watt densities, when air-cooled heat sinks are inadequate, liquid-cooled cold plates are the ideal high-performance heat transfer solution. With its broad range of different cold plate technologies, AMS Technologies meets the most specific fluid compatibility and performance requirements. Friction stir welded (FSW) aluminium cold plates are suitable for glycol-water and high power semiconductor cooling needs, while press-lock types with copper or stainless steel tubing are ideal for tap or de-ionised water. For special applications, cold plates with vacuum brazing, flat extrusions or pin fins are available.

cold plates for 62 mm power semiconductor modules

These liquid cooled cold plates are specifically designed for three or four IGBT power modules measuring 108 mm x 62 mm in a compact and lightweight design. With their advanced features, the cold plates provide efficient heat transfer between the cold plate contact area and the IGBT module base plate as well as a good temperature uniformity across and between modules.

cold plates for PrimePack 3 power semiconductor modules

Our cold plates for three to nine PrimePack 3 modules have been designed for good thermal performance and good temperature uniformity across and between all modules even for low fluid flows. Available in different flow rate, pressure drop, inlet and outlet configurations, these cold plates utilize modern fluid channel geometries and friction stir welding for cost effective and safe construction.

cold plates for 140 × 190 mm² power semiconductor modules

For the standard format of 140 × 190 mm² footprint IGBT modules, various cold plates are available for mounting up to eight modules. With very good thermal performance and temperature uniformity across and between modules, also at lower flow rates, the thermal resistance per module can be as low as 3 K/kW for average fluid temperatures.

general purpose cold plates

Our range of general purpose cold plate products include tubed cold plates (copper or stainless steel tubes pressed into a channeled aluminium extrusion), flat tube cold plates (internal fin to increase performance) and vacuum-brazed performance-fin cold plates (two plates metallurgically bonded together with internal fin).

light weight cold plates for low to medium power densities

Cold plates made of hot-rolled aluminium metal sheets feature substantially lower weight compared to conventional cold plates made of aluminium profiles. AMS Technologies supports you with a custom design aiming at low pressure drop and thermal uniformity over a large surface. This cost-effective technology is ideal for applications like cooling of batteries in transportation & traction.



cold plates for 62 mm power semiconductor modules

VK-275-150-18 (4 ×) IGBT power modules 108 mm × 62 mm

product dimensions

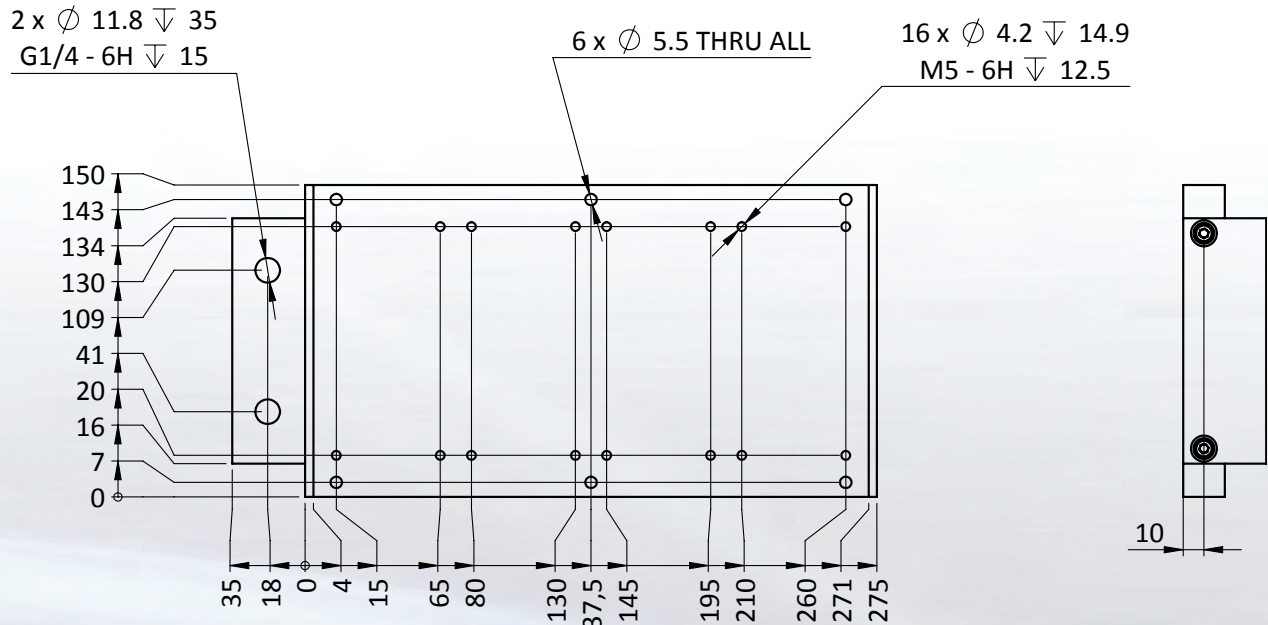

performance

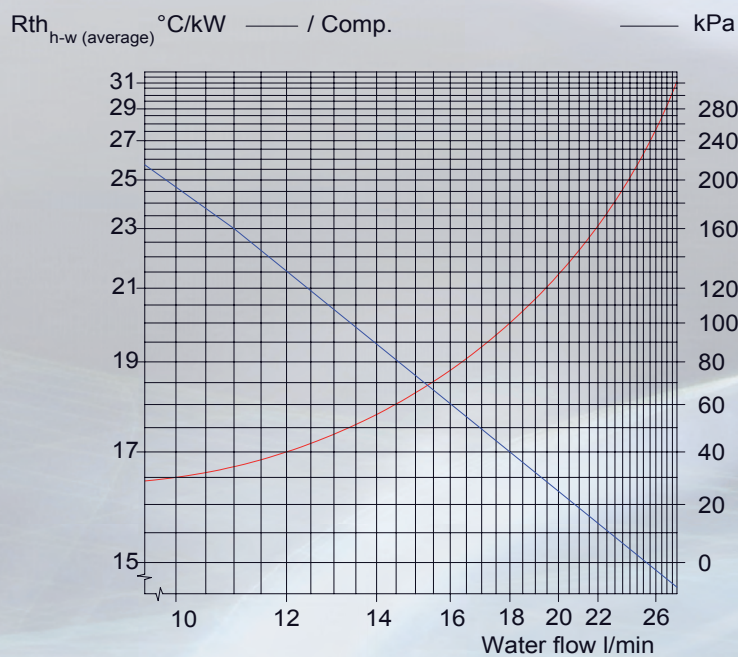

Water with 50 % Glycol
Maximum recommended flow 23 l/min

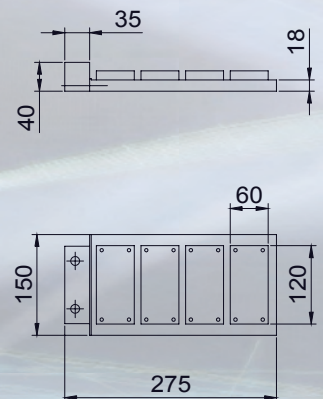

Contact us



cold plates for 62 mm power semiconductor modules

CP 3001 / CP 3001 XP (3 ×) IGBT power modules 108 mm × 62 mm

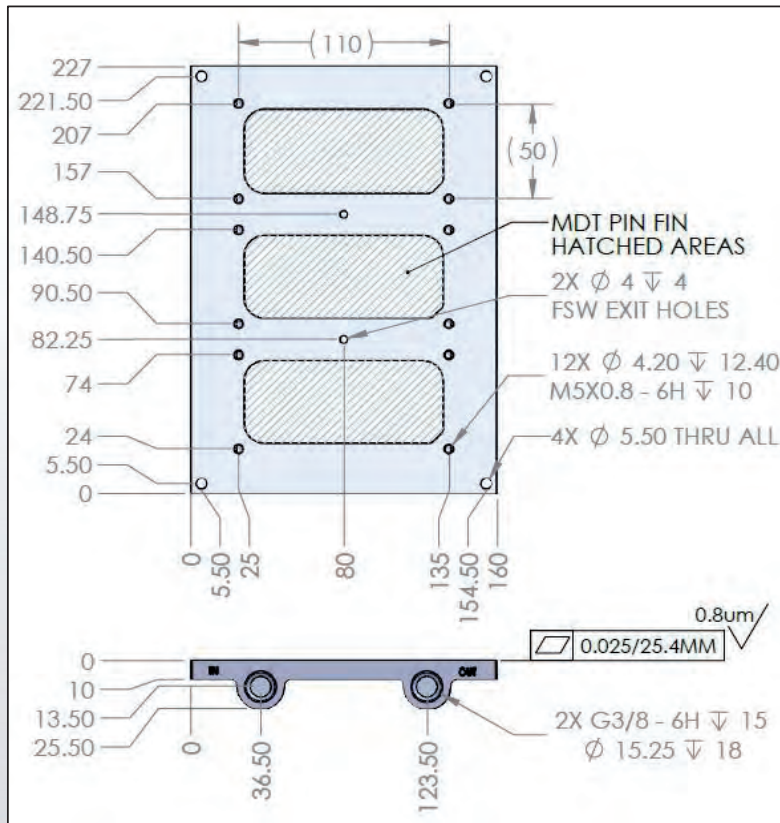

Designed to cool three 122x62mm power modules

- Tub Material: Al 6061
- Fin Plate Material : Al 1100-H14
- MDT in-line pin fin inside: Choice of 12 fins per inch or XP (extra performance, 20 fins per inch)
- Pressure tested to 5bar
- Mass: 1096 gr
- G3/8 (BSPP) ports
- Compatible with most coolants: ethylene glycol, propylene glycol, water, Opticool, Dowfrost, Dowtherm, Dynalene, 3M Novec

Custom Options

- Length: Extrusion length can change to accommodate up to 8 IGBTs
- Ports: NPT/SAE/BSPP (G)
- Plating options: Electroless Nickel inside and out available

Thermal Resistance (C/W)

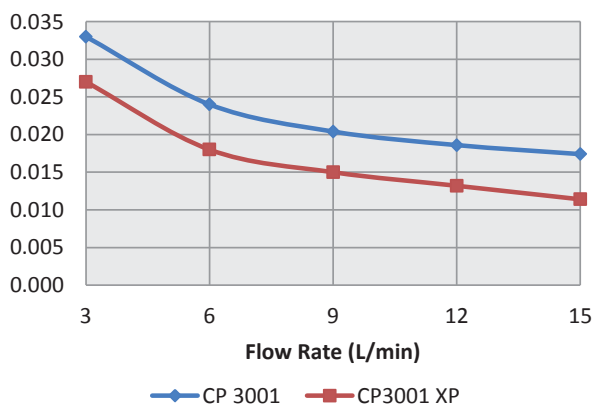

Pressure Drop (bar)

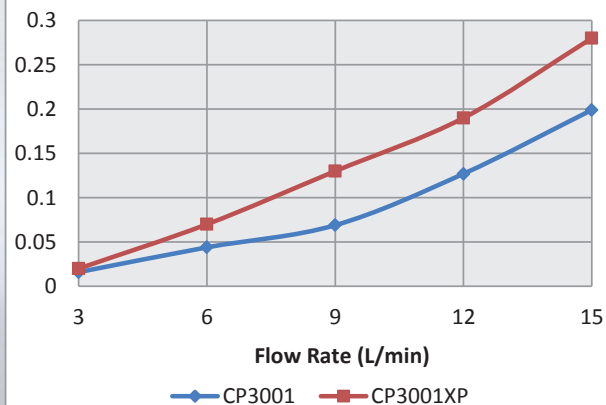

Thermal resistance calculated as the difference between the maximum coldplate surface temp. and the fluid Inlet temp. Fluid: 50/50 Ethylene Glycol & Water. Pressure Drop Includes G3/8 fittings. Empirically tested with 3 IGBT module sized heaters.



cold plates for 62 mm power semiconductor modules

WK270 × 150 × 29 (4 ×) IGBT power modules 108 mm × 62 mm

product dimensions

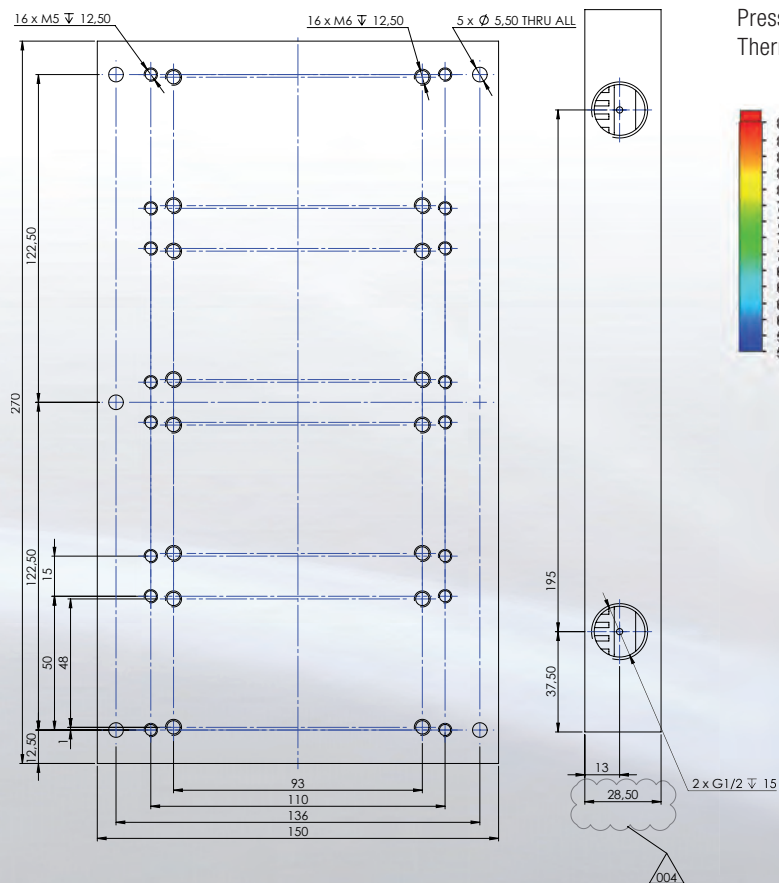

performance

Pressure drop: 100 mbar @ 15 l/min

Thermal resistance R_{th} : 24 K/kW

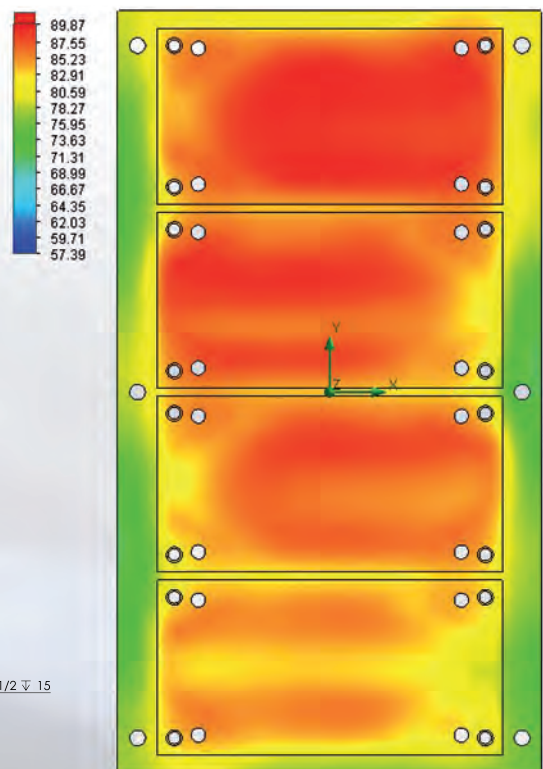

Temperature (Solid) [°C]

Surface Plot 1: contours

cold plates for PrimePack 3 power semiconductor modules

VK-370-300-22 (3 ×) PrimePack 3 (89 × 250)

product dimensions

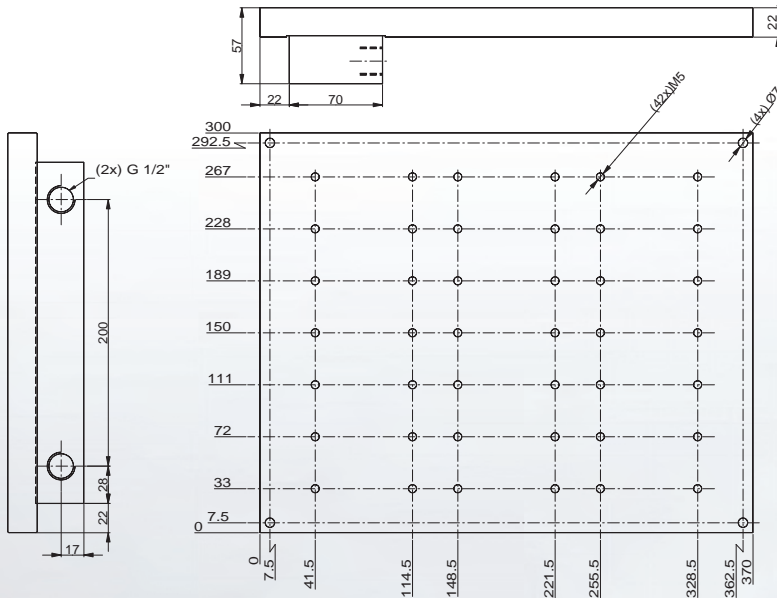

performance

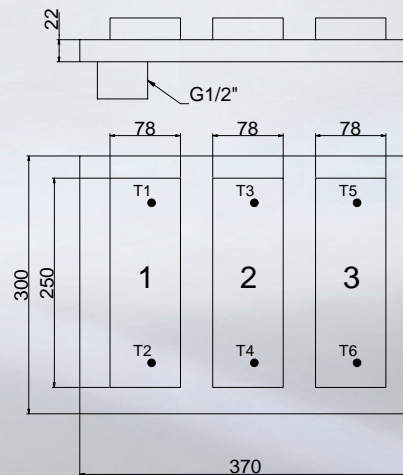
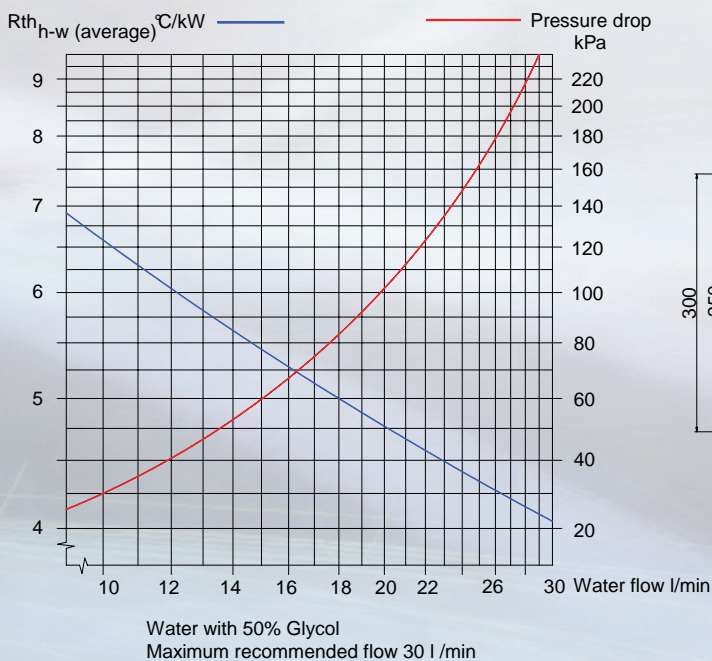

Measured
T1 - T2 = - 0.2°C / kW
T3 - T4 = +0.2°C / kW
T5 - T6 = +0.1°C / kW



cold plates for PrimePack 3 power semiconductor modules

VK-691-300-22 (6 ×) PrimePack 3 (89 × 250)

product dimensions

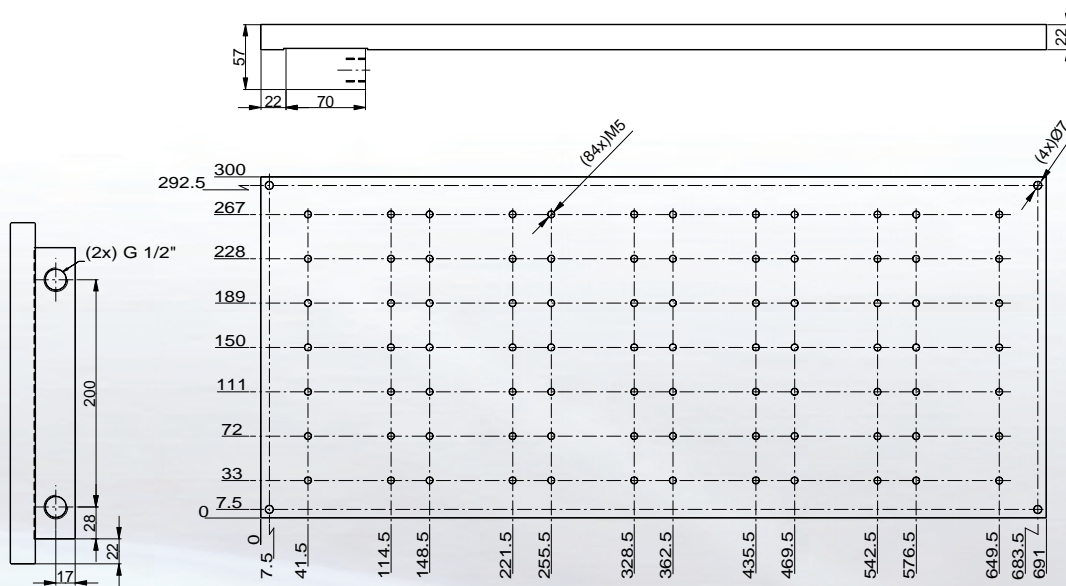

performance

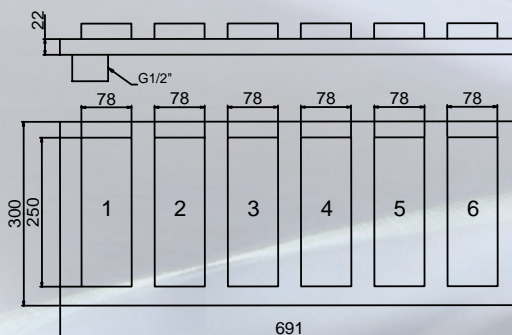
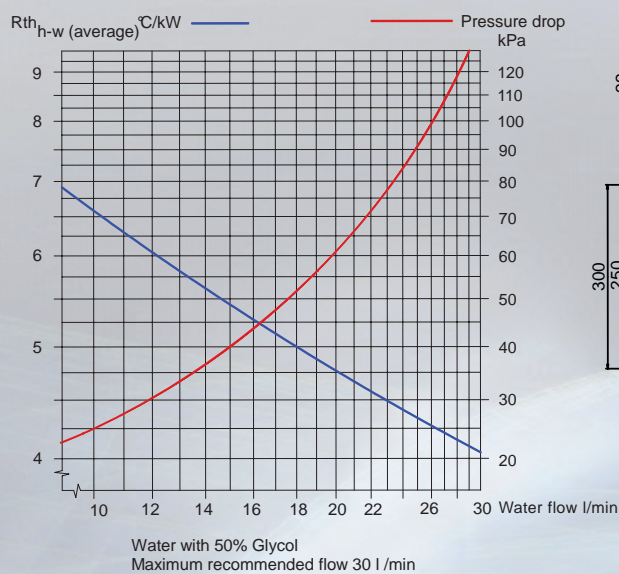

Contact us 



cold plates for 140 x 190 mm² power semiconductor modules

VK-430-150-22 (2 x) 140 x 190

product dimensions

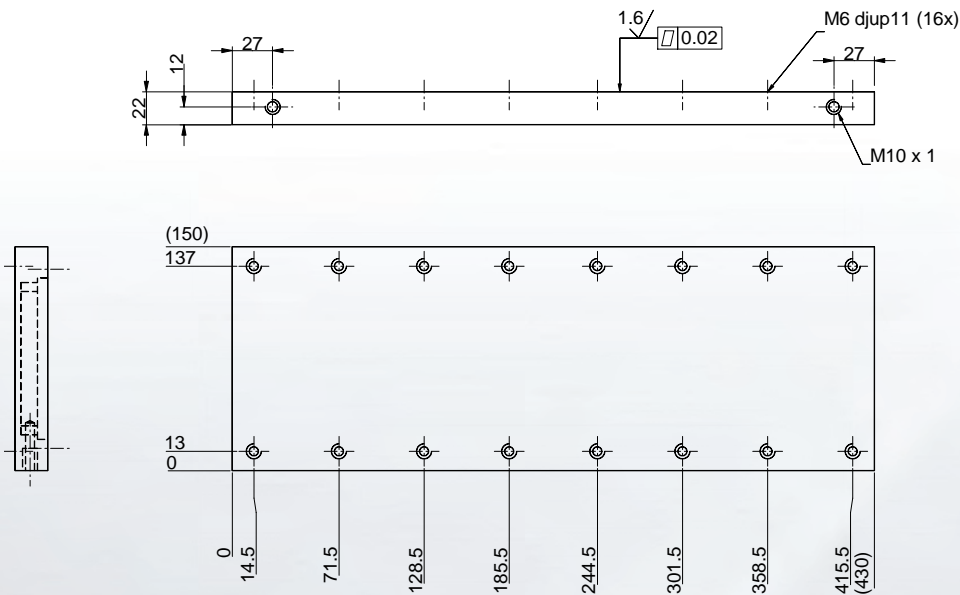

performance

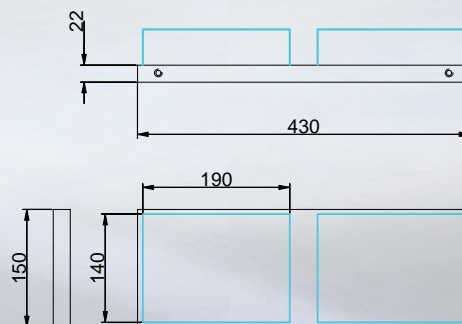
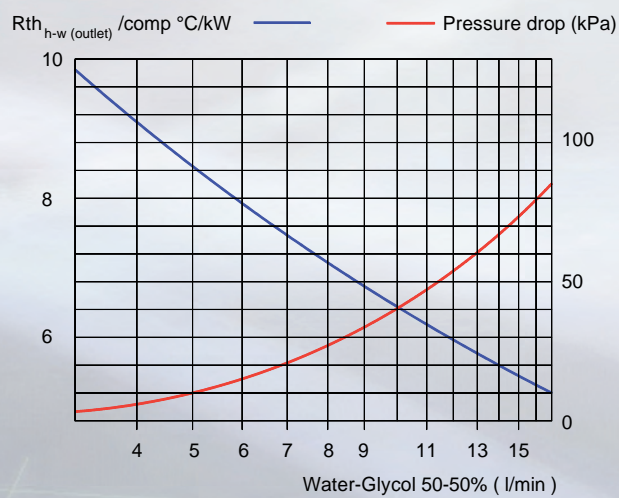

cold plates for 140 x 190 mm² power semiconductor modules

VK-920-400-20 (8 ×) 140 × 190 or double sided (16 ×) 140 × 190

product dimensions

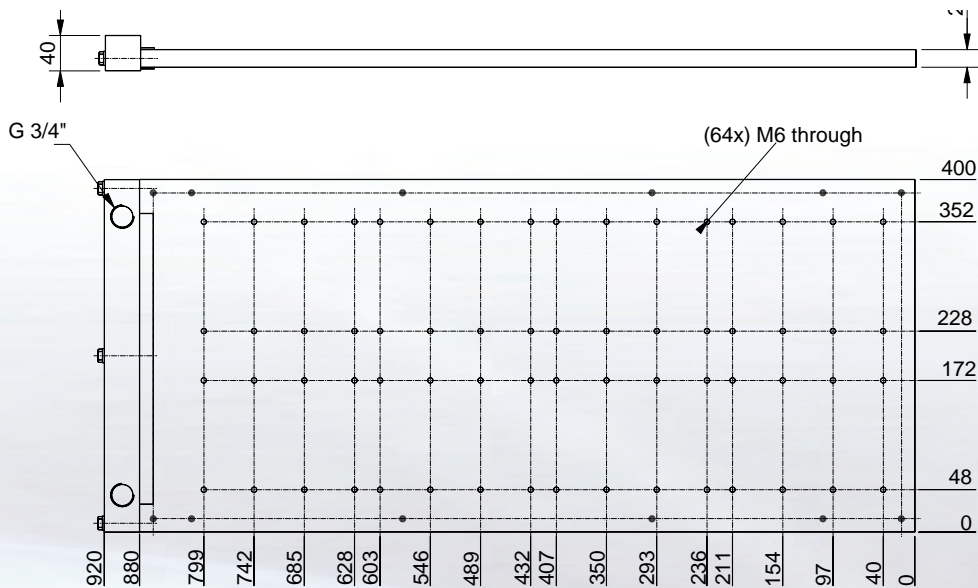

performance

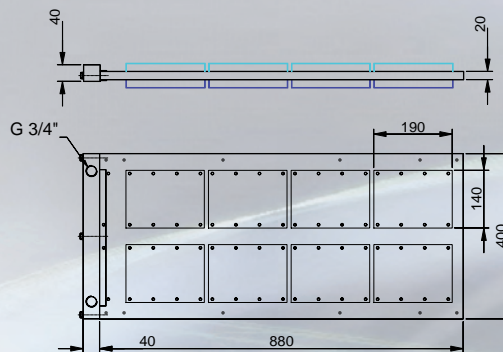
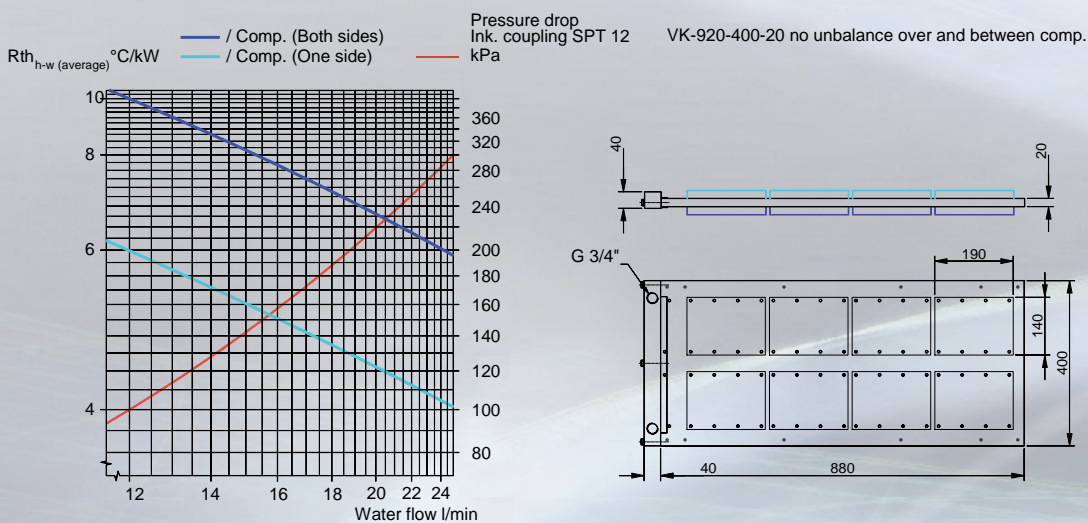

Recommended max. water flow 30 l/min

Contact us 



general purpose cold plates

CP10 tubed cold plate – 2-pass



Our range of standard tubed cold plates provide cost-effective thermal solutions for component cooling applications where the heat load is low-to-moderate. These tubed cold plates consist of copper or stainless steel tubes pressed into a channeled aluminium extrusion. This “Press-Lock” technology eliminates the need for performance-limiting epoxy between the tube and the plate,

resulting in superior thermal performance. Each tubed cold plate has a single tube with no joint, ensuring leak-free operation. The CP10 2-pass is a cost-effective, single-sided aluminium cold plate available with either copper or stainless steel tubes. It is ideal for component cooling applications where the heat load is low-to-moderate.

specifications

Dimensions L × W

(CP10G01, CP10G03) 152.4 mm × 88.9 mm / 6.0" × 3.5"

(CP10G05, CP10G07) 304.8 mm × 88.9 mm / 12.0" × 3.5"

Thickness 12.7 mm (0.5")

Performance

(CP10G01, CP10G03) 0.059 °C/W

(CP10G05, CP10G07) 0.029 °C/W

Fluid compatibility

(CP10G01, CP10G05) Water, common coolants

(CP10G03, CP10G07) Deionized water

Wetted path

(CP10G01, CP10G05) Copper

(CP10G03, CP10G07) Stainless steel

Mounting surface Single-sided

Tube 9.5 mm (3/8")

Configuration 2-pass

Fitting Straight (SB)

Plate material Aluminium

Maximum pressure 10 bar (150 psi)

Maximum flow rate 8 lpm

Shipping weight

(CP10G01, CP10G03) 0.68 kg / 1.5 lb

(CP10G05, CP10G07) 0.95 kg / 2.1 lb

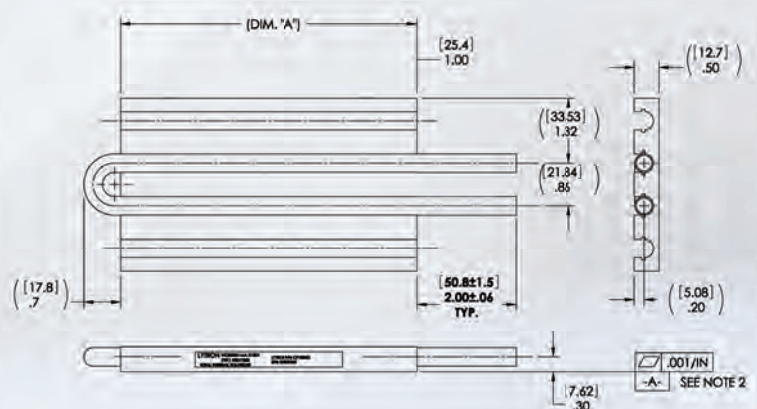

CP10 2-pass 152.4 mm (6.0")

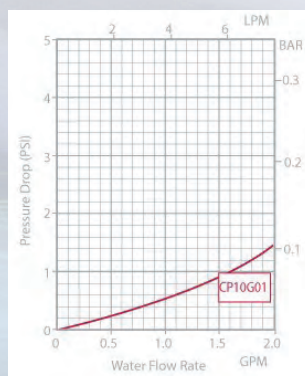
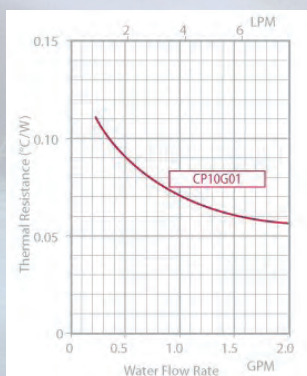

CP10 2-pass 304.8 mm (12.0")

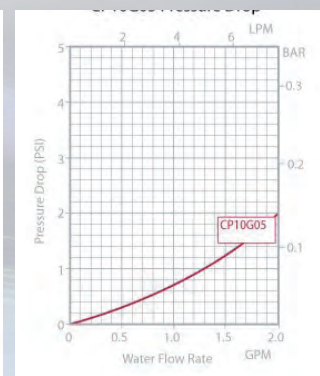
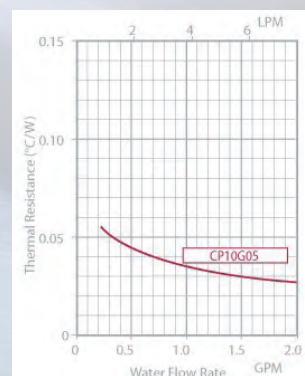

general purpose cold plates

Contact us 

CP10 tubed cold plate – 4-pass



Our range of standard tubed cold plates provide cost-effective thermal solutions for component cooling applications where the heat load is low-to-moderate. These tubed cold plates consist of copper or stainless steel tubes pressed into a channeled aluminium extrusion. This “Press-Lock” technology eliminates the need for performance-limiting epoxy between the tube and the plate,

resulting in superior thermal performance. Each tubed cold plate has a single tube with no joint, ensuring leak-free operation.

The CP10 4-pass is a cost-effective, single-sided aluminium cold plate available with either copper or stainless steel tubes. It is ideal for component cooling applications where the heat load is low-to-moderate.

specifications

Dimensions L × W

(CP10G14, CP10G16) 152.4 mm × 88.9 mm / 6.0" × 3.5"

(CP10G18, CP10G20) 304.8 mm × 88.9 mm / 12.0" × 3.5"

Thickness 12.7 mm (0.5")

Performance

(CP10G14, CP10G16) 0.051 °C/W

(CP10G18, CP10G20) 0.008 °C/W

Fluid compatibility

(CP10G14, CP10G18) Water, common coolants

(CP10G16, CP10G20) Deionized water

Wetted path

(CP10G14, CP10G18) Copper

(CP10G16, CP10G20) Stainless steel

Mounting surface Single-sided

Tube 9.5 mm (3/8")

Configuration 4-pass

Fitting Straight (SB)

Plate material Aluminium

Maximum pressure 10 bar (150 psi)

Maximum flow rate 8 lpm

Shipping weight

(CP10G14, CP10G16) 0.68 kg / 1.5 lb

(CP10G18, CP10G20) 0.95 kg / 2.1 lb

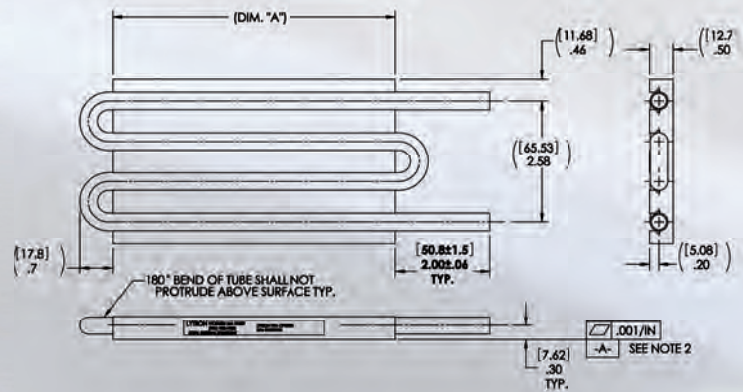

CP10 4-pass 152.4 mm (6.0")

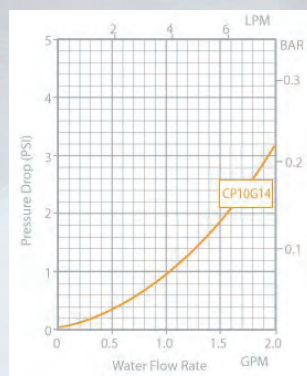
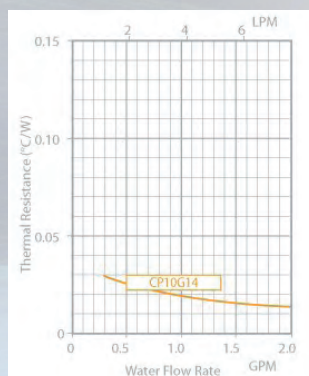

CP10 4-pass 304.8 mm (12.0")

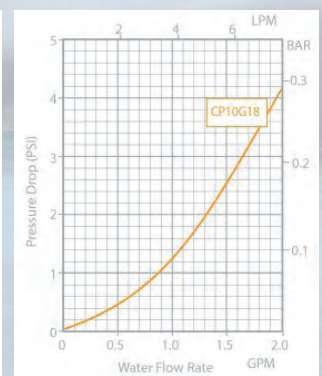
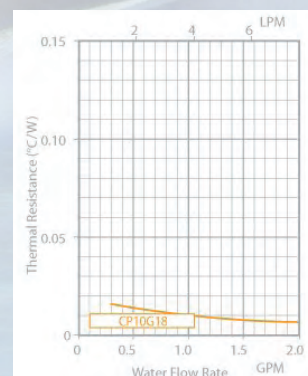

general purpose cold plates

CP12 tubed cold plate

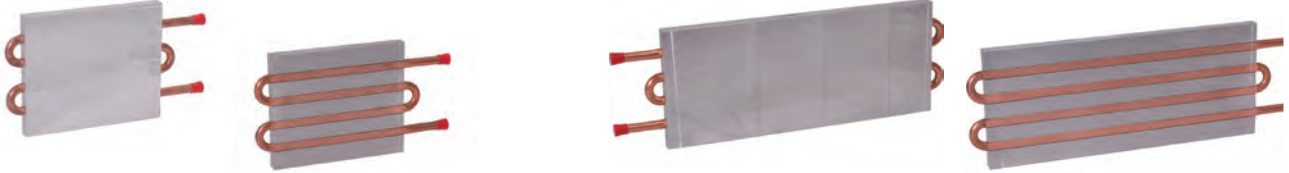

Our range of standard tubed cold plates provide cost-effective thermal solutions for component cooling applications where the heat load is low-to-moderate. These tubed cold plates consist of copper tubes pressed into a channeled aluminium extrusion. This “Press-Lock” technology eliminates the need for performance-limiting epoxy between the tube and the plate, resulting in superior thermal performance. Each tubed cold plate has a single tube with

no joint, ensuring leak-free operation. The CP12 is a dual-sided, copper tubed cold plate that offers high performance and a large mounting area. The tubes of the CP12 cold plates are coplanar with the plate to allow for dual-sided mounting. The cold plate’s tube side offers higher performance as the copper tubes are in direct contact with the component being cooled.

specifications

Dimensions L × W

(CP12G01) 152 mm × 127 mm / 6" × 5"
(CP12G05) 304 mm × 127 mm / 12" × 5"

Thickness 12.7 mm (0.5")

Performance

(CP12G01) 0.009 °C/W
(CP12G05) 0.004 °C/W

Fluid compatibility Water, common coolants

Wetted path Copper

Mounting surface Dual-sided

Tube 9.5 mm (3/8")

Configuration 4-pass

Fitting Straight (SB)

Plate material Aluminium

Maximum pressure 10 bar (150 psi)

Maximum flow rate 8 lpm

Shipping weight

(CP12G01) 1.00 kg / 2.2 lb

(CP12G05) 1.72 kg / 3.8 lb

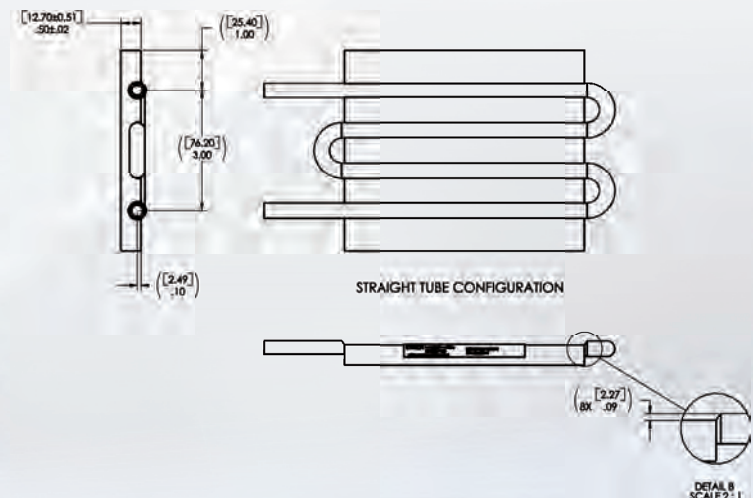

CP12 152 mm (6")

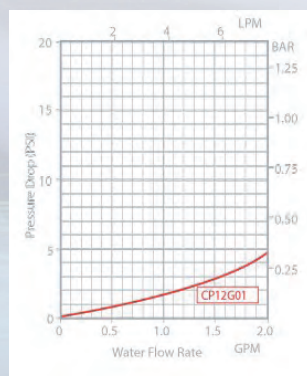
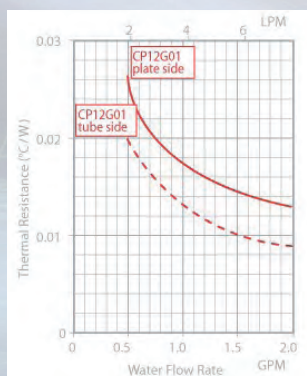

CP12 304 mm (12")

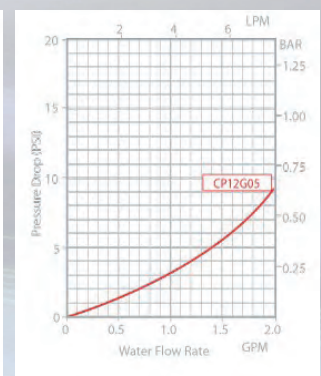
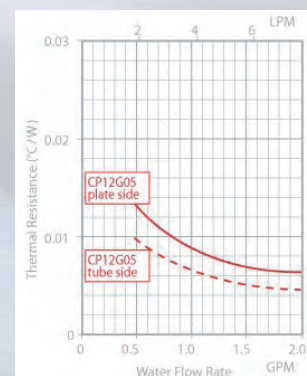

general purpose cold plates

[Contact us](#)

CP15 tubed cold plate



Our range of standard tubed cold plates provide cost-effective thermal solutions for component cooling applications where the heat load is low-to-moderate. These tubed cold plates consist of copper tubes pressed into a channeled aluminium extrusion. This “Press-Lock” technology eliminates the need for performance-limiting epoxy between the tube and the plate, resulting in superior thermal performance. Each tubed cold plate has a single tube with no joint, ensuring leak-free operation.

Components can be mounted on both sides of CP15, making this compact and lightweight cold plate ideal for applications where heat loads are moderating and space is at a premium. The tubes of the CP15 cold plates are coplanar with the plate to allow for dual-sided mounting. The cold plate’s tube side offers higher performance as the copper tubes are in direct contact with the component being cooled.

specifications

Dimensions L x W

(CP15G01) 152.4 mm x 95.3 mm / 6.0" x 3.8" "
 (CP15G05) 304.8 mm x 95.3 mm / 12.0" x 3.8" "

Thickness 7.6 mm (0.3")

Performance

(CP15G01) 0.008 °C/W
 (CP15G05) 0.004 °C/W

Fluid compatibility Water, common coolants

Wetted path Copper

Mounting surface Dual-sided

Tube 6.4 mm (1/4")

Configuration 6-pass

Fitting Straight (SB)

Plate material Aluminium

Maximum pressure 10 bar (150 psi)

Maximum flow rate 4 lpm

Shipping weight

(CP15G01) 0.95 kg / 1.3 lb

(CP15G05) 1.13 kg / 2.5 lb

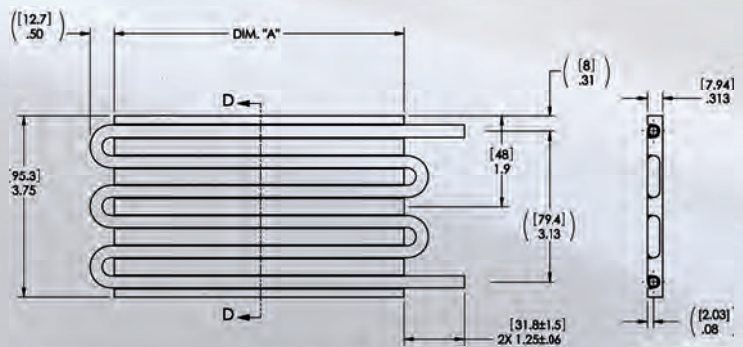

CP15 152.4 mm (6")

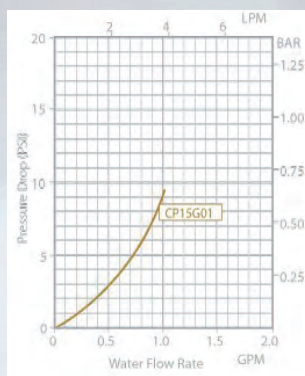
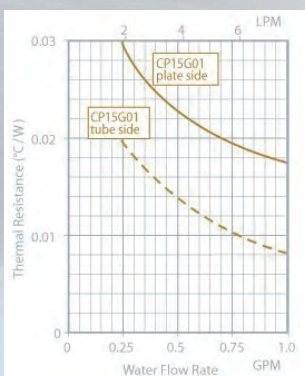

CP15 304.8 mm (12")

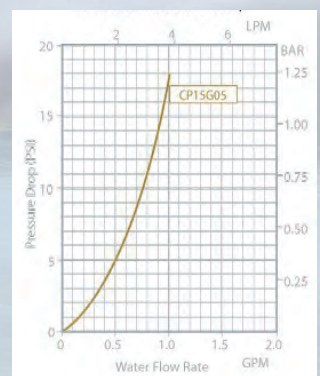
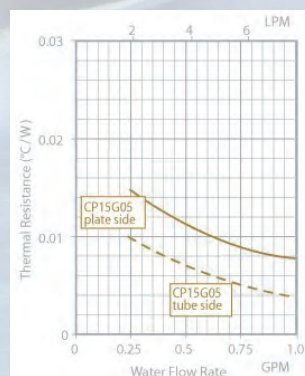

general purpose cold plates

CP20 flat tube cold plate



Our CP20 aluminium flat tube cold plates are very thin, compact, and lightweight cold plates, consisting of header tubes welded to a unique micro-channel aluminium extrusion. These cold plates offer extremely low thermal resistance, achieved by thin mounting surfaces and internal fin, which create a large surface. They feature excellent thermal uniformity as coolant flows below the entire surface. Their high performance and small size make

them ideal for cooling small, high watt-density components such as thermoelectric modules. The CP20 cold plates are only 3.3 mm (0.13") thick and 0.05 kg (0.1 lbs), making them a perfect fit for applications where space is limited. Their large internal surface area combined with low pressure drop make the CP20 ideal for use with viscous and poor heat transfer fluids such as EGW, oils, Fluorinert® and Polyalphaolefin (PAO).

specifications

Dimensions L x W	51 mm x 51 mm (2" x 2")
Thickness	3.3 mm (0.1")
Performance	0.044 °C/W
Fluid compatibility	EGW, oils
Wetted path	Aluminium
Mounting surface	Single-sided
Tube	9.5 mm (3/8")
Configuration	U (CP20G01), Z (CP20G03)
Fitting	Straight (SB)
Plate material	Aluminium
Maximum pressure	10 bar (150 psi)
Maximum flow rate	4 lpm
Shipping weight	0.27 kg / 0.6 lb

CP20 flat tube cold plate

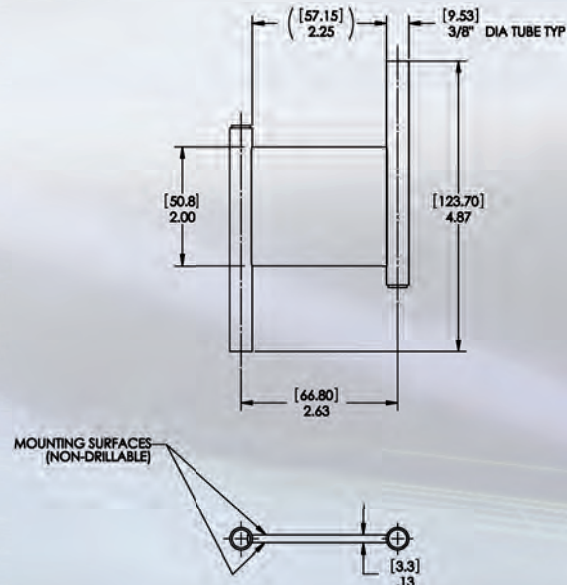
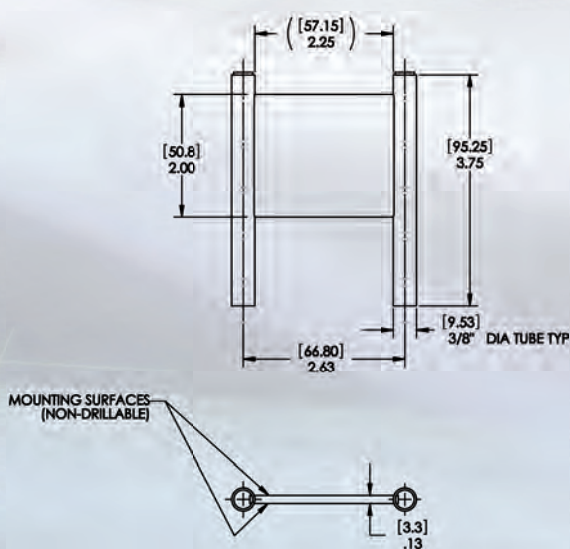
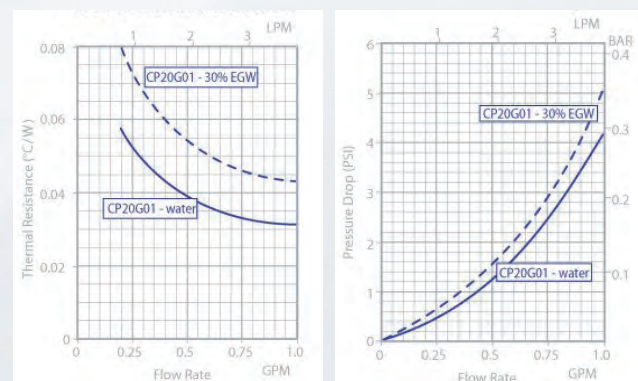

general purpose cold plates

CP30 vacuum brazed cold plate

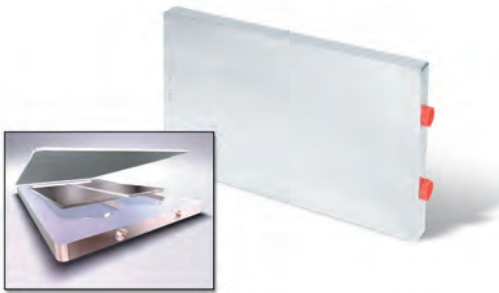

Performance-fin cold plates offer extremely high performance and consist of two plates vacuum-brazed together with internal fin. Our standard performance-fin cold plate is our aluminium CP30.

It offers a large 198 mm × 279 mm (7.8" × 11") mounting area so it is ideal for both board and multiple component liquid cooling in high heat load applications. It is flat on both sides to allow dual-sided mounting, and the surface on one side is 13 mm (0.5") thick to enable machining, drilling, and tapping for board/component attachment.

The CP30 cold plate is designed for prototyping purposes; most volume applications require customized cold plates tailored to precisely match performance and geometric requirements. The CP30 cold plate contains high performance corrugated aluminium fin brazed into the cavity beneath the mounting surface of the cold plate. The fin creates turbulence, which minimizes the fluid boundary layer and reduces thermal resistance.

specifications

Dimensions L × W	198.1 mm × 279.4 mm (7.8" × 11")
Thickness	19.05 mm (0.75")
Performance	0.005 °C/W
Fluid compatibility	EGW, oils
Wetted path	Aluminium
Mounting surface	Dual-sided
Configuration	Square
Fitting	9/16-18 UNF-2B
Plate material	Aluminium
Maximum pressure	10 bar (150 psi)
Maximum flow rate	23 lpm
Shipping weight	2.95 kg / 6.5 lb

CP30 vacuum brazed cold plate

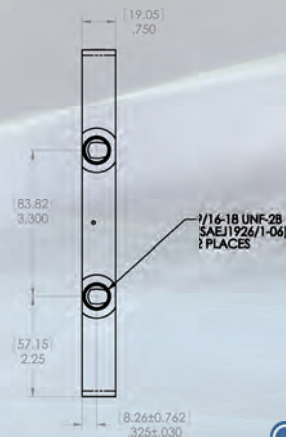
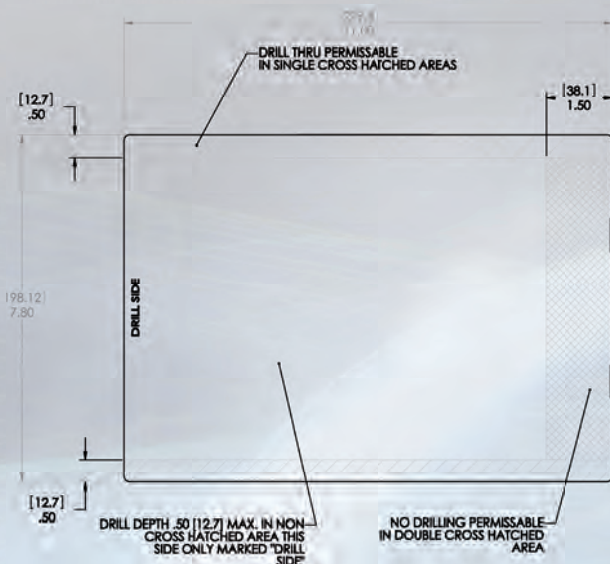
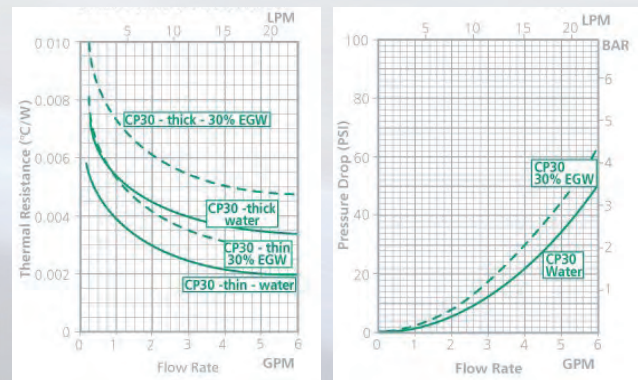

Contact us 



light weight cold plates for low to medium power densities

cost effective cold plates with uniform temperature distribution

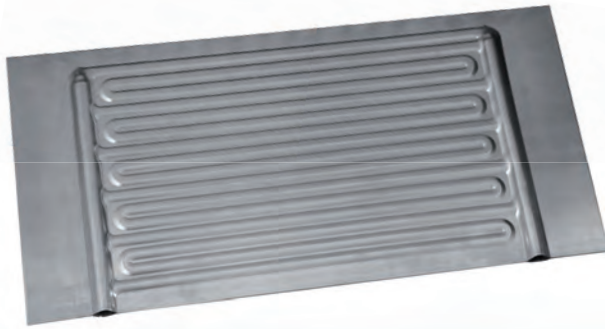

key features

- custom design optimized for low pressure drop
- uniform temperature distribution across the plate surface
- cost effective
- ideal for battery cooling applications in transportation & traction

main specifications (typical)

Plate thickness	4 mm
Weight	4 to 9 kg/m ²
Cooling surface flatness	approx. 0.2 mm
Materials	Al 1050 + 5005
Cooling fluid	Water/Ethylene Glycol 50–50, HFC134a, R600a
dT across plate	approx. 3 K

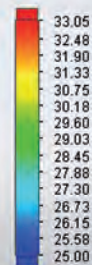
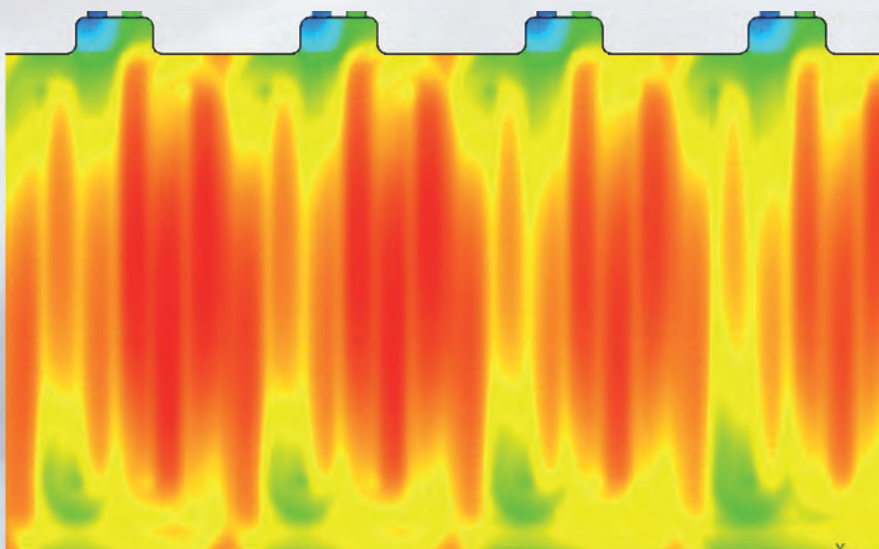

Temperature (Solid) [°C]
Surface Plot 1: contours



associated products

recirculating chillers



Featuring precise temperature control, quiet operation and high reliability, our recirculating chillers range from compact thermoelectric chillers with a cooling capacity of 160 W to a multitude of stand-alone and rack-mount devices

based on thermoelectric or compressor engines to very powerful chillers capable of dealing with heat loads up to 95 kW. Beyond the standard versions, a variety of options can be provided for different fluids, pumps, low temperatures below freezing, control and monitoring, additional heating and other aspects – all the way to fully customized solutions tailored to your requirements.

compressors



Our miniature rotary compressors are the result of a breakthrough in compressor technology featuring low vibration and low noise operation. They can be utilized in many thermal management applications from compact recirculating

chillers, cabinet coolers, direct cooling of electronic components, and white goods to mobile refrigeration. For smooth and easy temperature adjustment, these miniature rotary BLDC compressors with cooling capacities up to 2000 W are continuously speed-controllable via the frequency of a square wave signal. The inverter board is included, a test function board for easy evaluation is also available as an option.

heat exchangers



AMS Technologies' heat exchanger portfolio includes tube-fin heat exchangers (copper or stainless steel tubes expanded into copper or aluminium fin for good and cost effective heat removal), oil cooler flat tube heat exchangers

(aluminium flat tube fluid channels vacuum brazed with aluminium fin for optimum cooling with poor heat transfer fluids such as oil and EGW) and liquid-to-liquid brazed plate heat exchangers (herringbone construction for efficient maximum heat transfer in a compact and reliable package)

temperature sensors

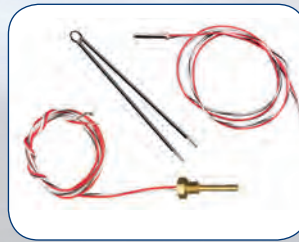

Accurate and fast temperature sensors are essential for precision temperature control. Amongst the different types of temperature sensors, thermistors provide very high sensitivity, small size and appropriate speed. AMS Technologies' extensive range of NTC thermistor temperature sensor probes with base resistance values from 5 k Ω to 231.5 k Ω include various types from ultraminiature bare bead, epoxy coated and pipe versions (poly-imide, brass, brass nickel, stainless steel – threaded and unthreaded) to flange mount and plate models. Sizes range from 0.5 mm to 6.5 cm with Teflon coated lead lengths from 5 cm to 45 cm.

Contact us 



from technology components to turnkey solutions

We want to accelerate your success, which is why AMS Technologies has invested in two design centers: in Krakow, Poland, and in the United Kingdom. Our goal is to augment your team's key competencies by providing engineering services that are not core to you or where you may struggle with available resources to finish your projects.

From design services to prototype development to complete turnkey solutions, our collaborative approach has already helped many customer projects to move from concept to production.

- Design, prototyping and "proof of concept"
- Development of turnkey solutions to the customer's order
- Design-in, systems integration, realization of entire design projects
- Development of customized specification sheets
- Effective project management of any product development
- Interdisciplinary system-level integrated design
- Appropriate subcontractor selection and production support
- Simulations and modeling of system-level designs
- Installation, training and servicing

full chiller power in shoe box size



Our mini Recirculating Chiller development kit (mRC-KIT) mRC-C-450-100/240 features a vapor compression circuit and a closed, pressurized recirculating water circuit – like a conventional

chiller five times the size. On the refrigeration side, a miniature rotary compressor, customized condenser and evaporator are utilized to reduce size. The twin pump compressor's BLDC motor is speed controlled by an inverter, offering low vibration and low noise throughout the speed range. Compact centrifugal pumps and a compact tank on the water circuit side are also contributing to the compact size. Due to pressure applied on the suction side, the water pumps operate smoothly and without cavitation and the closed system prevents ingress of bacteria and oxygen, keeps the coolant clean and thus helps to extend maintenance intervals.

custom cooling unit for biomedical reagents

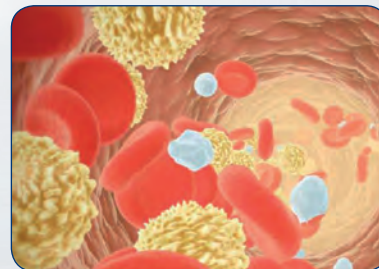

A haemostasis analyzing instrument performs various tests to measure blood coagulation. In one area of the instrument the blood samples are kept at a constant tempera-

ture of +37°C. Right next to the blood samples the reagents need to be conserved at constant +15 °C. The cooling of the reagents is done by forced air flow. For a redesign of the cooling system in their haemostasis analyzer, a French pharmaceutical laboratory turned to AMS Technologies.

After careful empirical investigation and determination of the cooling capacity, AMS Technologies developed a customized cooling unit with a powerful 24 VDC mini compressor with linear speed control, small evaporator and condenser heat exchangers, fans and other components of a refrigeration cycle – and successfully placed all these components inside the given restricted space. During the development the AMS Technologies experts also optimized air flow rate and duct to achieve uniform temperatures across the reagents.



SOLUTIONS



enabling your ideas.

Optical, Power and Thermal Management Technologies

■ GERMANY

AMS Technologies AG
Fraunhoferstr. 22
82152 Martinsried, Germany
Phone + 49 (0) 89 895 77 0

■ ITALY

AMS Technologies S.r.l.
Via Copernico, 21
20025 Legnano (MI), Italy
Phone + 39 0331 596 693

■ SPAIN

AMS Technologies S.L.
C/Filadors 35, 3º, 7ª
08208 Sabadell, Spain
Phone + 34 93 380 84 20

■ FRANCE

AMS Technologies S.A.R.L.
Silic 649 – Bâtiment Magnolia
16, avenue du Québec
91945 Courtaboeuf Cedex
Phone + 33 (0) 1 64 86 46 00

■ NORDICS

AMS Technologies Nordics
Azpect Photonics AB
Aminogatan 34
431 53 Mölndal, Sweden
Phone + 46 (0) 8 55 44 24 80

■ UNITED KINGDOM

AMS Technologies Ltd.
Nene House, Drayton Way
Davertry, Northamptonshire
NN11 8EA, United Kingdom
Phone + 44 (0)1455 556360

Download Brochure



Intertek

info@amstechnologies.com
www.amstechnologies.com
www.amstechnologies-webshop.com