

DATASHEET AND OPERATING GUIDE

WLD3343 & WLD3393

Laser Diode Driver & Evaluation Board

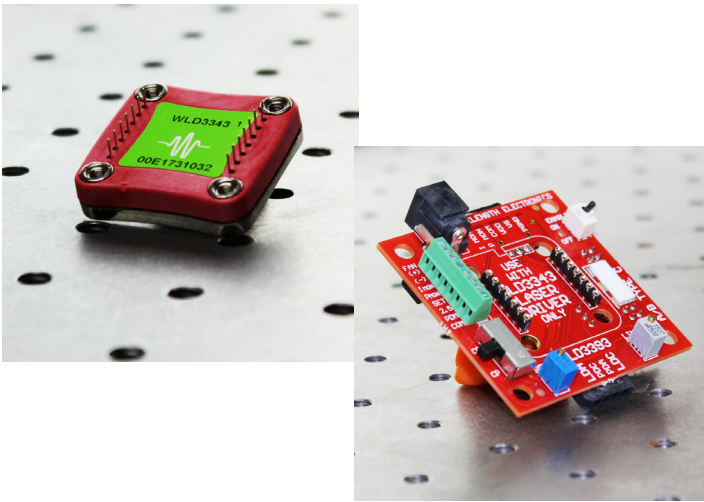

FEATURES AND BENEFITS

- Low cost
- Slow-start laser diode protection
- Drive up to 3 A output current
- Constant Current or Constant Power operation
- Compatible with any laser diode type
- Small package size (1.3" × 1.26" × 0.3")
- Voltage-controlled setpoint
- TTL-compatible shutdown pin
- Adjustable current limit
- Adjustable current range
- 2 MHz Constant Current bandwidth
- Over-temperature shutdown
- 14-pin DIP PCB mount

SMALL FOOTPRINT

The WLD3343 is an easy-to-use analog circuit for space constrained laser diode applications. The WLD3343 maintains precision laser diode current (Constant Current mode) or stable photodiode current (Constant Power mode) regulation using electronics that are compatible with any laser diode type. Safely supply up to 3 A of current (model-dependent) to a laser diode from a single +5 V power supply.

MODEL VARIATIONS

There are five laser diode driver models available in the WLD family. The standard WLD3343 provides up to 2.2 A to the laser diode. The WLD3343-3A provides up to 3 A. The WLD3343-2L and WLD3343-3L are lower noise versions for Constant Current mode of the 2.2 and 3 A models, respectively. The WLD3343-HB is designed to operate with lower voltage supplies, including lithium-ion batteries.

RAPID PROTOTYPING

Use the WLD3393 Evaluation Board to rapidly prototype a complete laser diode control system using the of the WLD3343 laser diode driver. Onboard switches, connectors, and trimpots make the configuration and operation simple. Input and output cables are also included with the WLD3393.

The WLD3343 is excellent for VCSELs, electro-optical equipment, and medical/dental systems.

ACCESSORIES

In addition to the WLD3393 Evaluation Board, there are thermal management kits designed specifically for the WLD. WEV300 includes a thermal washer and heatsink. WEV301 adds a +5 V fan, while WEV302 adds a +12 V fan to the kit. Additionally, there are various power supplies available that fit any current/voltage needs.

CONTENTS

- QUICK CONNECT GUIDE
- PIN DESCRIPTIONS
- ELECTRICAL SPECIFICATIONS
- SAFETY INFORMATION
- OPERATING INSTRUCTIONS – GENERAL
- OPERATING INSTRUCTIONS – STANDALONE
- OPERATING INSTRUCTIONS – WITH EVALUATION BOARD
- ADDITIONAL TECHNICAL INFORMATION
- TROUBLESHOOTING
- MECHANICAL SPECIFICATIONS
- CERTIFICATION AND WARRANTY

PAGE ORDERING INFORMATION

PAGE	PART NO	DESCRIPTION
2		
4	WLD3343	2.2 A Laser Diode Driver
6	WLD3343-3A	3 A Laser Diode Driver
8	WLD3343HB	2.2 A Li+ Battery-compatible Driver
9	WLD3343-2L	2.2 A Lower Noise Driver (CC only)
10	WLD3343-3L	3 A Lower Noise Driver (CC only)
16	WLD3393	Evaluation PCB
22	WTW002	Thermal Washer for all WLDs
25	WHS302	Heatsink for all WLDs
26	WXC303	+5 VDC Fan for all WLDs
28	WXC304	+12 VDC Fan for all WLDs



406-587-4910

www.teamWavelength.com

QUICK CONNECT GUIDE



TO ENSURE SAFE OPERATION OF THE WLD3343 DRIVER, IT IS IMPERATIVE THAT YOU DETERMINE THAT THE UNIT WILL BE OPERATING WITHIN THE INTERNAL HEAT DISSIPATION **SAFE OPERATING AREA (SOA)**.

Visit the Wavelength Electronics website for the most accurate, up-to-date, and easy to use SOA calculator:

www.teamwavelength.com/support/design-tools/soa-ld-calculator/

Enter your operating voltages and currents to determine if the system will operate robustly or if heatsinking, fan, or lower voltage power supplies are required.

Figure 1 shows the top view of the WLD3343 driver with pin layout and descriptions.

Figure 2 shows a typical wiring diagram for the WLD3343 driver to operate a Type A or B laser in Constant Current mode. Refer to **page 13** and **page 14** for additional wiring diagrams, including Constant Power wiring diagrams, and Type C laser wiring diagrams.

An online circuit calculator tool is available, which automatically determines values for external components, including R_{LIM} , R_{SENSE} , V_{SET} , along with R_{PD} if operating in Constant Power mode:

www.teamwavelength.com/support/design-tools/wld-calculator/

TOP VIEW

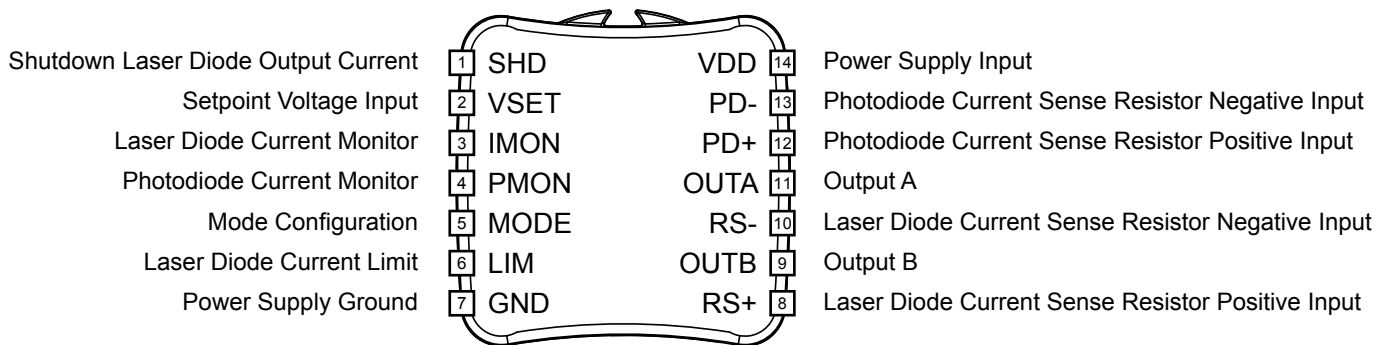
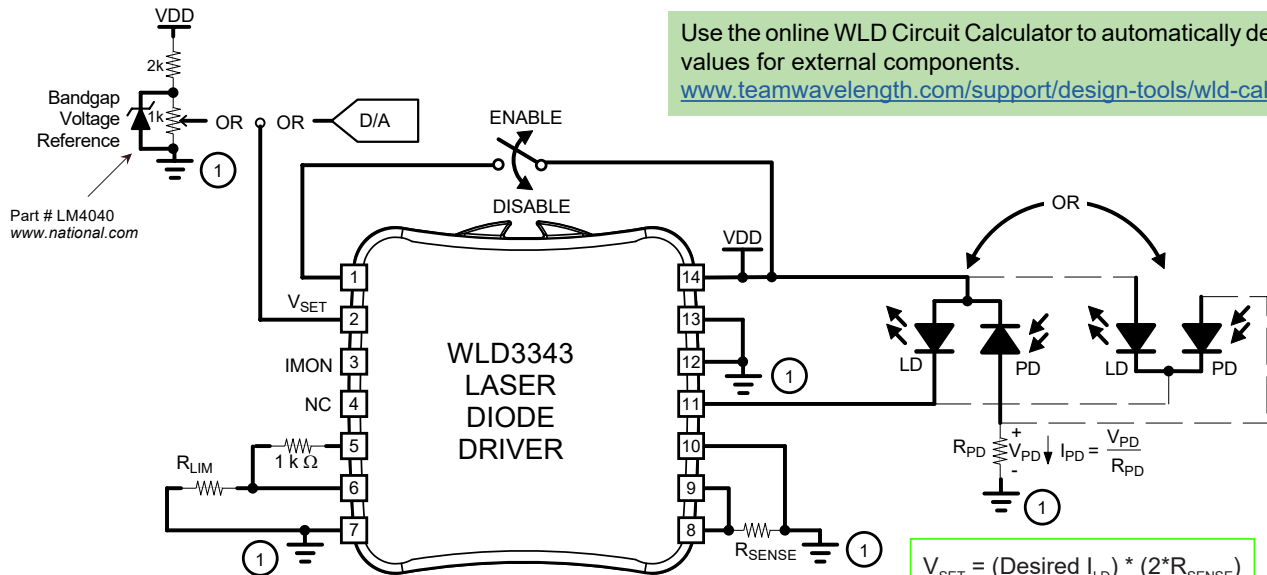

Figure 1. Top view and pinout of the WLD3343 laser diode driver.



Use the online WLD Circuit Calculator to automatically determine values for external components.
www.teamwavelength.com/support/design-tools/wld-calculator/

① TIE GROUND CONNECTIONS DIRECTLY TO PIN 7

VALUE	DETAILS
V_{SET}	Eq. (9) on page 15
IMON	Eq. (11) on page 15
R_{LIM}	Eq. (7) on page 11
R_{SENSE}	Eq. (3) on page 10

$V_{SET} = (\text{Desired } I_{LD}) * (2 * R_{SENSE})$

Without Evaluation Board

$$R_{SENSE} = \frac{1.00}{I_{LDMAX}}$$

With Eval Board (Rev. Level)

LD Range	R_{SENSE} (Rev. C)	R_{SENSE} (Rev. A&B)
2.0 A	438 mΩ	500 mΩ
200 mA	5.01 Ω	5.1 Ω

Figure 2. Quick Connect Diagram: Type A/B laser diodes in Constant Current mode operation.

The WLD3343 Series of laser diode drivers are able to drive lasers with any pinout of laser diode and photodiode. **Figure 3** illustrates these laser types. For detailed instructions on using the different laser types refer to the **Operating Instructions — General** along with the **Operating Instructions — Standalone** and **Operating Instructions — With Evaluation Board** depending on the desired operation.

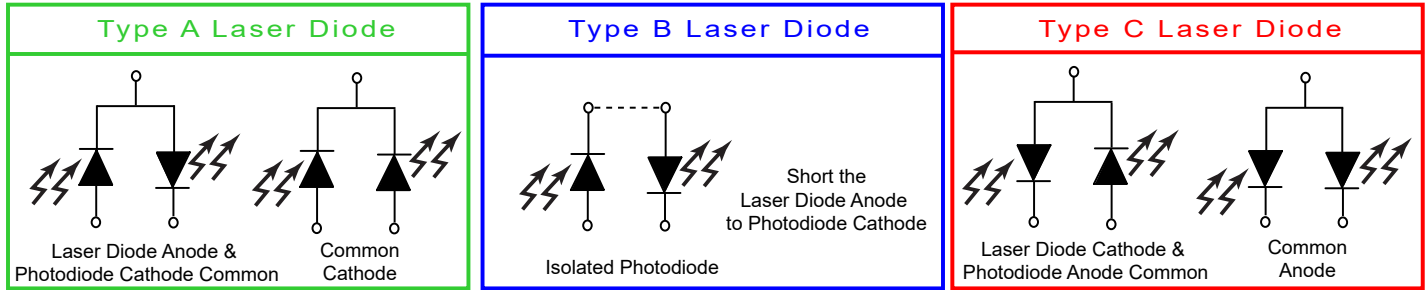

Figure 3. Laser type diagrams. The WLD3343 can operate Type A, B, and C laser diodes.

RECOMMENDED TEST LOAD

For initial setup and configuration, we recommend using a test load with the WLD. The test load takes the place of the laser diode in the corresponding wiring diagram.

- For standalone operation:
 - » Type A/B wiring diagrams on **page 13**.
 - » Type C wiring diagrams on **page 14**.
- For operation with the WLD3393 evaluation board:
 - » Connect the test load across the LDA and LDC terminals.

When using the test load, the actual drive current can be determined by measuring the voltage drop across the resistor. Do not place an ammeter in series with the load circuit.

Wavelength recommends using a power resistor. The resistance value is calculated using

$$R_{LOAD} = \frac{V_s - 2.5}{I_{LIM}} \quad (1)$$

and the power rating of the resistor is found by

$$P_{RLOAD} = I_{LIM}^2 \cdot R_{LOAD} \quad (2)$$

For example, if V_s is 12 V, and the current limit is 2 A, then R_{LOAD} needs to be 4.75 Ω with a power rating of 19 W.

PIN DESCRIPTIONS

Table 1. Pin Descriptions

PIN	LABEL	NAME	PIN DESCRIPTION
1	SHD	Shutdown Laser Diode Output Current	Enable or disable output current to the laser diode using this pin. To ENABLE: Float or connect a zero volt signal to this pin. To DISABLE: Connect a +3 V or greater signal to this pin.
2	V _{SET}	Setpoint Voltage Input or Modulation Input	Connect a voltage source between this pin and Pin 7 (GND) to control either the laser diode current in Constant Current mode or the laser diode power in Constant Power mode. Range is 0-2 V full scale. Input impedance is 20 kΩ. Offset voltage is 0.5 V when open (applies to Revision D forward). Do not let this pin float, or damage to the load may result.
3	IMON	Laser Diode Current Monitor	Monitor the laser diode forward current using this pin. The laser diode current monitor produces a voltage proportional to the current flowing through the laser diode. <i>Standalone:</i> Transfer function depends on R _{SENSE} value. See Equation (11) on page 15 . <i>Evaluation Board:</i> See Table 10 on page 20 for the transfer function.
4	PMON	Photodiode Current Monitor	Monitor the laser diode power using this pin. The photodiode current monitor produces a voltage proportional to the current produced by the laser diode monitor photodiode. <i>Standalone:</i> Transfer function depends on R _{PD} value. See Equations (12) & (13) on page 15 . <i>Evaluation Board:</i> See Table 11 on page 20 for the transfer function.
5	MODE	Mode Configuration	Configure either Constant Current or Constant Power operation using this pin. <i>Constant Current:</i> Install a 1 kΩ resistor between this pin and Pin 6 (LIM). <i>Constant Power:</i> Install a 0.1 μF capacitor between this pin and Pin 6 (LIM).
6	LIM	Laser Diode Current Limit	A resistor connected between this pin and Pin 7 (GND) limits the maximum amount of forward current through the laser diode. See page 11 for more information.
7	GND	Power Supply Ground	Connect the V _{DD} power supply ground connection to this pin.
8	RS+	Laser Diode Current Sense Resistor Positive Input	Connect this pin directly to the positive side of the laser diode current sense resistor. The resistance value of R _{SENSE} determines the range of forward current through the laser diode.
9	OUTB	Output B	Connect this pin to the positive side of R _{SENSE} .
10	RS-	Laser Diode Current Sense Resistor Negative Input	Connect this pin directly to the negative side of the laser diode current sense resistor. The resistance value of R _{SENSE} determines the range of forward current through the laser diode.
11	OUTA	Output A	How this pin is configured depends on laser type. <i>Type A/B:</i> Connect this pin to the cathode connection of the laser diode. <i>Type C:</i> Connect this pin to Pin 14 (V _{DD}).
12	PD+	Photodiode Current Sense Resistor Positive Input	How this pin is configured depends on both laser type and operation mode. <i>Constant Current:</i> For all laser types, connect both this pin and Pin 13 (PD-) to Pin 7 (GND). <i>Constant Power:</i> For Type A/B lasers, connect this pin to the anode of the photodiode. For Type C lasers, connect this pin to Pin 14 (V _{DD}).
13	PD-	Photodiode Current Sense Resistor Negative Input	How this pin is configured depends on both laser type and operation mode. <i>Constant Current:</i> For all laser types, connect both this pin and Pin 12 (PD+) to Pin 7 (GND). <i>Constant Power:</i> For Type A/B lasers, connect this pin to Pin 7 (GND). For Type C lasers, connect this pin to the cathode of the photodiode.
14	V _{DD}	Power Supply Input	Power supply input for the internal control electronics. Supply range input for this pin is model-dependent.

Table 2. Description of jumper connections and functionality on the WLD3393 Evaluation Board.

JUMPER	OPTIONS	FUNCTION
LD RANGE	200 mA or 2 A	Configures the laser diode output current range to either 200 mA or 2 A.
PD RANGE	200 μ A or 2 mA	Configures the photodiode current range to either 200 μ A or 2 mA.
POWER SELECT	Separate or tied power supplies	Configures the WLD3393 to either use separate V_s and V_{DD} supplies, or to tie the V_s and V_{DD} connections for single supply operation.
VSET SOURCE	T or X	Configures the WLD3393 to either use the onboard setpoint trimpot (T) or the external setpoint input (X). If a combination of onboard and external setpoints is required, the jumper should be placed in the "T" position, and an external setpoint connected.

For more information about the jumpers on the bottom of the WLD3393 evaluation board, see **page 17**.

ELECTRICAL SPECIFICATIONS

PARAMETER	SYMBOL	VALUE	UNIT	NOTE
ABSOLUTE MAXIMUM RATINGS				
Supply Voltage (at Pin 14)	V_{DD}	+4.5 to +12.5 +3.3 to +6	VDC	WLD3343, -3A, -2L, -3L WLD3343HB
Output Current	I_{LD}	2.2 3.0	A	WLD3343, -2L, HB WLD3343-3A, -3L
Power Dissipation ($T_{AMBIENT}=25^{\circ}\text{C}$)	P_{MAX}	9 10	W	WLD3343, -2L, HB WLD3343-3A, -3L
Operating Temperature Range (Case) [1]	T_{OPR}	-40 to +85 -40 to +45	$^{\circ}\text{C}$	WLD3343, -2L, HB WLD3343-3A, -3L
Storage Temperature Range	T_{STG}	-65 to 150	$^{\circ}\text{C}$	
Weight		0.6	oz	17 grams
Size		1.28 × 1.30 × 0.31	in	32.5 mm × 33.0 mm × 7.9 mm

PARAMETER	MODEL			UNIT	NOTE
	WLD3343HB	WLD3343-2A WLD3343-2L	WLD3343-3A WLD3343-3L		
DRIVE CURRENT OUTPUT					
Max Output Current	2.2	2.2	3	A	
Compliance Voltage, Laser Diode Load, $V_{DD} = 5\text{ V}$		3.6		V	$I_{LD} = 100\text{ mA}$
		3.5		V	$I_{LD} = 1.0\text{ A}$
		3.0		V	$I_{LD} = 2.0\text{ A}$
	N/A	N/A	2.8	V	$I_{LD} = 3.0\text{ A}$
Compliance Voltage, Laser Diode Load, $V_{DD} = 12\text{ V}$	N/A	10.6	10.6	V	$I_{LD} = 100\text{ mA}$
	N/A	10.4	10.4	V	$I_{LD} = 1.0\text{ A}$
	N/A	10.1	10.1	V	$I_{LD} = 2.0\text{ A}$
	N/A	N/A	9.8	V	$I_{LD} = 3.0\text{ A}$
Rise Time		460		ns	$I_{LD} = \text{Full Scale}$
Fall Time		320		ns	$I_{LD} = \text{Full Scale}$
Bandwidth [2]		2		MHz	CC, Sine Wave, 2A
Slow Start – Delay Time		0.24		sec	
Slow Start – Ramp Time		0.01		sec	
Leakage Current [3]		0		mA	
CONSTANT CURRENT CONTROL					
Short Term Stability, 1 hour	25 to 50	200	200	ppm	$T_{AMBIENT} = 25^{\circ}\text{C}$
CONSTANT POWER CONTROL					
Short Term Stability, 1 hour		0.01		%	$T_{AMBIENT} = 25^{\circ}\text{C}$
Long Term Stability, 24 hours		0.05		%	$T_{AMBIENT} = 25^{\circ}\text{C}$

[1] With Revision D forward of the WLD3343, an internal thermostat has been added to activate Shutdown (SHD) when the internal temperature exceeds 105°C . The output will be re-enabled after a 250 to 300 ms slow-start once the internal temperature drops below 95°C .

[2] Bandwidth in Constant Power mode depends on photodiode bandwidth.

[3] Leakage current specification is based on full current set by R_{SENSE} . See **page 10** for information on setting the current range. Minimum turn-on current in the 200 mA range is 350 μA . Minimum turn-on current in the 2 A range is 12 mA. This specification applies to Revision E forward.

Noise: To further reduce noise, the WLD3343-2L and WLD3343-3L models are available. Both are about 2.5 times lower noise than the WLD3343 and WLD3343-3A, respectively. Constant Power (CP) mode is not available in these models.

ELECTRICAL SPECIFICATIONS (CONTINUED)

PARAMETER	MODEL			UNIT	NOTE
	WLD3343HB	WLD3343-2A	WLD3343-3A		
INPUT					
Offset Voltage, initial, I_{MON}	1			mV	Pin 2, $T_{AMBIENT}=25^{\circ}C$, $V_{CM}=0$ V
V_{SET} Bias Current [4]	-50 to 150			μA	
V_{SET} Input Voltage Range	0 to 2			V	
Power Supply Rejection	80			dB	Full Temperature Range
V_{SET} Damage Threshold	> 5.4 or < -0.5			V	
V_{SET} Input Impedance	20			k Ω	
THERMAL					
Max Internal Power Dissipation (No Heatsink, No Airflow)	1.2	1.2	2	W	$T_{AMBIENT} = 25^{\circ}C$
Max Internal Power Dissipation (Heatsink, No Airflow)	2	2	3	W	$T_{AMBIENT} = 25^{\circ}C$
Max Internal Power Dissipation (Heatsink, Fan)	9	9	10	W	$T_{AMBIENT} = 25^{\circ}C$
Heatspreader Temperature Rise $T_{AMBIENT} = 25^{\circ}C$	30			$^{\circ}C / W$	No heatsink, washer, fan.
	21.5			$^{\circ}C / W$	With WHS302 Heatsink, WTW002 Thermal Washer
	3.4			$^{\circ}C / W$	With WHS302 Heatsink, WTW002 Thermal Washer, and 3.5 CFM Fan
Pin Solderability Time [5]	10			s	Solder temperature 260 $^{\circ}C$
POWER SUPPLY					
Voltage, V_{DD}	3.3 to 6	5 to 12	5 to 12	V	
Current, V_{DD} Supply, Quiescent	10			mA	
MONITOR ACCURACY					
Monitor Voltage vs. Expected Output Current	0.5			%	Based on transfer function
PD Monitor vs. Actual	3.3			%	
Setpoint vs. Actual	3.5			%	

[4] As V_{SET} approaches zero volts, the V_{SET} signal source must sink up to 50 μA . As V_{SET} approaches 2 V, the V_{SET} signal source must source up to 150 μA .

[5] Not compatible with aqueous cleaning processes.

SAFETY INFORMATION

SAFE OPERATING AREA – DO NOT EXCEED INTERNAL POWER DISSIPATION LIMITS

Before attempting to operate the WLD3343 driver, it is imperative that you first determine that the unit will operate within the *Safe Operating Area* (SOA). Operating outside of the SOA may damage the laser and the WLD3343. Operating outside of the SOA will void the warranty.

To determine if the WLD3343 driver will be operating in a safe range, follow the instructions for calculating the Safe Operating Area online with your system's voltages and current requirements:

www.teamwavelength.com/support/design-tools/soa-ld-calculator/

SOA charts are included in this datasheet for quick reference (**page 23**), but we recommend you use the online tools instead.



TO ENSURE SAFE OPERATION OF THE WLD3343 DRIVER, IT IS IMPERATIVE THAT YOU DETERMINE IF THE UNIT IS GOING TO BE OPERATING WITHIN THE INTERNAL HEAT DISSIPATION SAFE OPERATING AREA (SOA).

If you have any questions about the Safe Operating Area calculator, call the factory for free and prompt technical assistance.

THERMAL MANAGEMENT KITS

The WLD Series of laser diode drivers have many thermal management accessories. They include thermal washers, heatsinks, and fans. These products are available either as individual accessories, or bundled together in kits. The use of these thermal management accessories helps ensure that the WLD will remain in the SOA during operation.

THEORY OF OPERATION

The WLD Series drivers are voltage controlled current sources: they deliver the current commanded by the setpoint. The control system continually monitors the actual output current, compares it to the setpoint, and adjusts the current if there is a difference between the two signals.

It may be useful to remember that you do not directly set the drive current setpoint; instead, you adjust a voltage signal that represents the output current. The voltage and output current are related by a transfer function that varies by driver model number and maximum current.

The setpoint voltage is adjusted at Pin 2 (V_{SET}). In standalone operation, this is the only way to vary the setpoint. If using the evaluation board, there are trimpots that can also adjust the setpoint.

The adjustable current limit is set by choosing the resistor R_{LIM} in standalone operation, or with a trimpot if using the evaluation board.

As current is driven through the laser diode load, there is a voltage drop across the load because of its impedance. As the current increases, the voltage drop may increase to the point that it reaches the Compliance Voltage limit of the current source. Once that occurs, the current source is no longer able to increase the current driven to the load even if you increase the setpoint.

The WLD drivers include features that help protect your laser and make the driver more versatile in a wide array of applications:

- The user-adjustable clipping current limit protects the laser from over-current situations by never allowing the output current to exceed the user-set limit. If the setpoint is greater than the limit, the WLD will hold the output current at the limit.
- Operate in Constant Current or Constant Power mode. Constant Current keeps the current through the laser diode constant, while Constant Power keeps the current through the monitor photodiode constant (proportional to output power).
- Output current switches on after a 250 ms overall delay from the time the enable signal is applied.
- The ENABLE pin must be held low or left floating in order to have current enabled from the laser driver. To disable output, connect greater than 3 V to Pin 1.
- Low leakage current, excellent for VCSELs.

OPERATING INSTRUCTIONS – GENERAL

The WLD3343 drivers have dual in-line pin (DIP) packaging, and are intended to be mounted onto a circuit board. Parameters including output current range, output current limit, photodiode current range, and operating mode are configured by proper choice of external components.

We recommend using a test load until you are familiar with operation of the driver. Refer to **page 3** for test load information.

These instructions are broken into three sections. The first covers generally applicable operating instructions that are relevant whether or not the optional evaluation board is being used. The second configures the driver for standalone operation without the evaluation board (**page 10**). The third configures the driver for operation with the evaluation board (**page 16**).

NECESSARY EQUIPMENT

The following equipment is the minimum necessary to configure the WLD3343 for basic operation:

- WLD3343 controller
- Digital voltmeter, 4-½ digit resolution recommended
- Test load for configuring the driver
- Laser diode, mount, and optional temperature control system
- Recommended heat sink and optional fan
 - » WTW002 Thermal Washer
 - » WHS302 Heatsink
 - » WXC303 (+5 VDC) or WXC304 (+12 VDC) Fan
- Custom circuit board, or WLD3393 evaluation board
- Power supply (see below)

POWER SUPPLY REQUIREMENTS

Linear-regulated or low-noise switching power supplies can be used. We recommend using power supplies with noise specifications suitable for your application.

For WLD3343, WLD3343-3A, WLD3343-2L, WLD3343-3L:

- 4.5 to 12.5 VDC power supply rated for 1.1-times the maximum laser diode current, plus 150 – 250 mA for the electronics.

For WLD3343-HB:

- 3.3 to 6 VDC power supply rated for 1.1-times the maximum laser diode current, plus 150 – 250 mA for the electronics.
- The HB offers low voltage operation for use with a Lithium-ion battery or other low voltage power supplies.

PREVENT DAMAGE FROM ELECTROSTATIC DISCHARGE

Before proceeding, it is critical that you take precautions to prevent electrostatic discharge (ESD) damage to the driver and your laser. ESD damage can result from improper handling of sensitive electronics, and is easily preventable with simple precautions.

For more information on ESD, see Application Note [AN-LDTC06: Basics: Electrostatic Discharge \(ESD\)](#).

We recommend that you always observe ESD precautions when handling the WLD3343 driver and your laser diode.

ONLINE TOOLS AVAILABLE

An online tool, the [WLD Circuit Calculator](#), is available to assist in the choosing of external components that impact operation. It is customizable for laser type, and operation mode. This automatically calculates the required external component values including R_{LIM} , R_{SENSE} , V_{SET} , and R_{PD} (if operating in Constant Power mode).

OPERATION MODE

The WLD Series supports Constant Current and Constant Power modes of operation (with the exception of the -2L and -3L models, which only support Constant Current). Depending on the chosen operation mode, either the current through the laser diode or the current through the photodiode will be maintained at a fixed level.



DO NOT SWITCH THE CONTROL MODE WHILE THE OUTPUT IS ENABLED AND DRIVING A LASER DIODE. THE LASER DIODE MAY BE DAMAGED OR DESTROYED.

Constant current through the laser diode is referred to as Constant Current mode, and is abbreviated CC. In CC mode, the setpoint is directly proportional to the laser diode current.

Constant current through the monitor photodiode is referred to as Constant Power mode and is abbreviated CP. In CP mode, the setpoint is directly proportional to the photodiode current, allowing for control of the power emitted from the laser diode.

OPERATING INSTRUCTIONS – STANDALONE

WLD CIRCUIT CALCULATOR

The online [WLD Circuit Calculator](#) automatically calculates the required external component values based on operating parameters. Use this tool to quickly and easily configure the WLD without the calculations found in this section.

SELECT THE LASER DIODE OUTPUT CURRENT RANGE

The output current range of the WLD3343 depends on the selection of current sense resistor R_{SENSE} placed between Pin 8 (RS+) and Pin 10 (RS-) as shown in **Figure 4**.

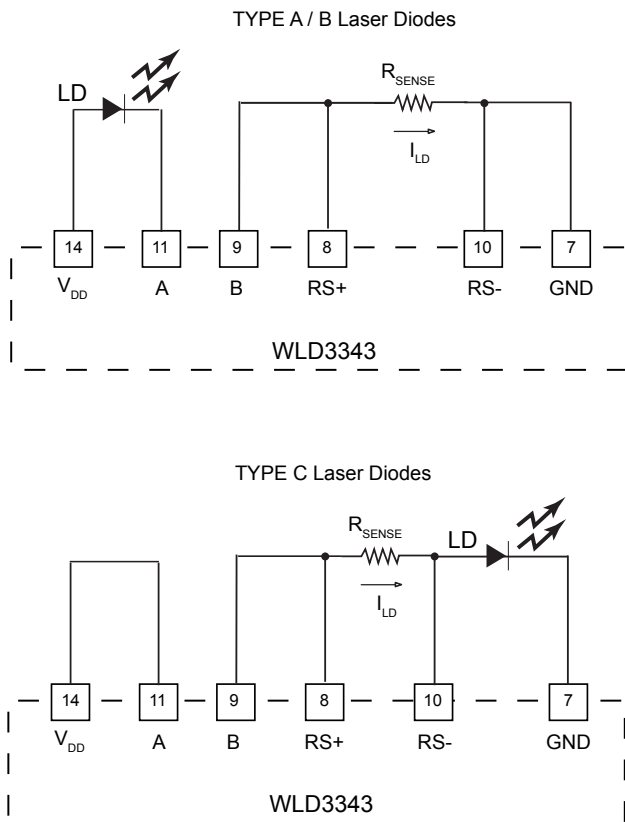

Figure 4. R_{SENSE} is connected between Pin 8 and Pin 10.

To calculate R_{SENSE} for a maximum desired laser diode current I_{LDMAX} , use **Equation (3)** for Constant Power operation and **Equation (4)** for Constant Current. Refer to **Table 3** to select R_{SENSE} for common laser diode current ranges.

$$R_{SENSE,CP} = \frac{1.25}{I_{LDMAX}} \quad (3)$$

$$R_{SENSE,CC} = \frac{1.00}{I_{LDMAX}} \quad (4)$$

I_{LDMAX}	CONSTANT POWER R_{SENSE}	CONSTANT CURRENT R_{SENSE}
50 mA	25.00 Ω	20.00 Ω
125 mA	10.00 Ω	8.00 Ω
250 mA	5.00 Ω	4.00 Ω
500 mA	2.50 Ω	2.00 Ω
1.25 A	1.00 Ω	0.80 Ω
2.2 A	0.57 Ω	0.45 Ω
<i>WLD3343-3A & WLD3343-3L ONLY:</i>		
3 A	0.42 Ω	0.33 Ω

Table 3. Determine the proper sense resistor (R_{SENSE}) value based on maximum output current (I_{LDMAX}), depending on operation mode.

HELPFUL HINTS FOR CHOOSING R_{SENSE}

- Never use a carbon film resistor for R_{SENSE} .
- Avoid resistors with high parasitic inductance.
- Select a resistor with a low temperature coefficient (1% \approx 100 ppm/ $^{\circ}$ C).
- Place R_{SENSE} as close to Pins 8 (RS+) and 10 (RS-) on the WLD3343 as possible to avoid parasitic resistance effects from the PCB layout.
- Use **Equation (5)** for determining the power rating of R_{SENSE} .

NOTE: Wavelength Electronics recommends a conservative power rating of 2 times normal maximum for R_{SENSE} . **Equation (5)** incorporates this recommendation.

$$P_{RATING} = 2 \cdot I_{LDMAX}^2 \cdot R_{SENSE} \quad (5)$$

CHOOSE OPERATION MODE: CC OR CP

The WLD3343 can operate in either Constant Current or Constant Power mode. Configuring the WLD operation mode is accomplished by installing:

- a 1 k Ω resistor between Pin 5 and Pin 6 for Constant Current mode.
- a 0.1 μ F capacitor between Pin 5 and Pin 6 for Constant Power mode.

CONFIGURE THE LASER DIODE CURRENT LIMIT

The WLD3343 allows a customized current range for a specific application. This allows optimized setpoint resolution while minimizing output noise. The current limit is set by properly choosing the limit resistor (R_{LIM}) and installing it between Pins 6 and 7.

There are two methods of choosing the appropriate resistance value R_{LIM} . The first uses the *normalized maximum output current* and **Table 5**. The second is a calculation using **Equation (7)**. Both methods depend on the laser diode type and mode of operation.

Method 1:

To find the normalized maximum output current, divide the desired laser diode current limit (I_{LDLIM}) by the maximum laser diode current (I_{LDMAX}), as shown in **Equation (6)**. Then, choose the resistance value of R_{LIM} shown next to the calculated normalized maximum output current in **Table 5**.

$$I_{MAX,NORM} = \frac{I_{LDLIM}}{I_{LDMAX}} \quad (6)$$

For example, consider using a Type A/B laser diode in Constant Current mode. If the WLD is configured to output a maximum current of 2.2 A, and the user wishes to set the limit current at 1.5 A, then the normalized maximum output current is 0.68 (1.5/2.2). This value then yields a value of R_{LIM} equal to 405 Ω (from **Table 5**)

Method 2:

To precisely calculate the value of R_{LIM} , use **Equation (7)**, and **Table 4** for the values of α and β .

$$R_{LIM} = \frac{\alpha \frac{I_{LDLIM} R_{SENSE} + 1}{\beta}}{1 - \frac{I_{LDLIM} R_{SENSE} + 1}{\beta}} \quad (7)$$

LASER DIODE TYPE – MODE	α	β
Type A/B – CC	282	2.85
Type A/B – CP	350	3.35
Type C – CC	290	2.93
Type C – CP	385	3.57

Table 4. Values of α and β to calculate R_{LIM} given laser type and operation mode.

Setting Current Limits Using Trimpots

Connect a 500 Ω trimpot and a 150 Ω resistor as shown in **Figure 5** to make the maximum current limit adjustable.

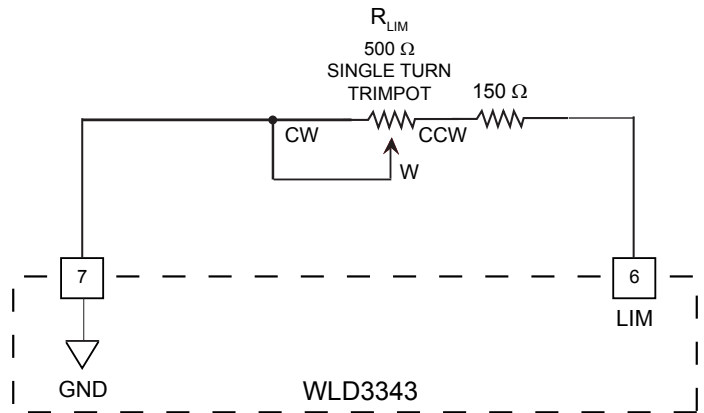

Figure 5. Use the configuration shown for adjustable current limits.

$I_{MAX,NORM}$	TYPE A/B CC R_{LIM} (Ω)	TYPE A/B CP R_{LIM} (Ω)	TYPE C CC R_{LIM} (Ω)	TYPE C CP R_{LIM} (Ω)
0.00	152	149	150	150
0.04	162	160	160	160
0.08	172	171	169	171
0.12	183	183	179	183
0.16	194	195	190	195
0.20	205	208	201	207
0.24	217	222	213	220
0.28	230	236	225	234
0.32	243	251	238	248
0.36	257	267	251	263
0.40	272	284	265	279
0.44	288	301	280	295
0.48	305	320	296	313
0.52	322	340	313	331
0.56	341	361	330	350
0.60	361	383	349	370
0.64	382	406	369	392
0.68	405	432	390	414
0.72	429	459	412	438
0.76	455	488	436	463
0.80	483	519	462	490
0.84	514	552	490	519
0.88	547	588	519	550
0.92	582	627	551	583
0.96	621	670	586	618
1.00	664	716	624	656

Table 5. Choose R_{LIM} as a function of normalized maximum output current, laser diode type, and operation mode.

Use the online WLD Circuit Calculator to automatically determine values for external components.
www.teamwavelength.com/support/design-tools/wld-calculator/

SELECTING THE MONITOR PHOTODIODE CURRENT RANGE

The monitor photodiode current range determines the selection of the resistor R_{PD} .

Equation (8) calculates R_{PD} for a maximum desired photodiode current, I_{PDMAX} . Refer to **Table 6** to select R_{PD} for common photodiode current ranges.

$$R_{PD} = \frac{1}{I_{PDMAX}} \quad (8)$$

I_{PDMAX}	R_{PD}
20 μ A	50 k Ω
200 μ A	5 k Ω
2 mA	500 Ω
20 mA	50 Ω

Table 6. Monitor photodiode sense resistor R_{PD} versus maximum photodiode current I_{PDMAX}

In Constant Power mode, the photodiode is used to control laser output and R_{PD} is connected across Pin 12 (PD+) and Pin 13 (PD-). In Constant Current mode, the photodiode is excluded from the control circuit and Pin 12 (PD+) and Pin 13 (PD-) are shorted together. The photodiode current can still be monitored in constant current mode with R_{PD} . Refer to **Figure 6** for photodiode resistor connections.

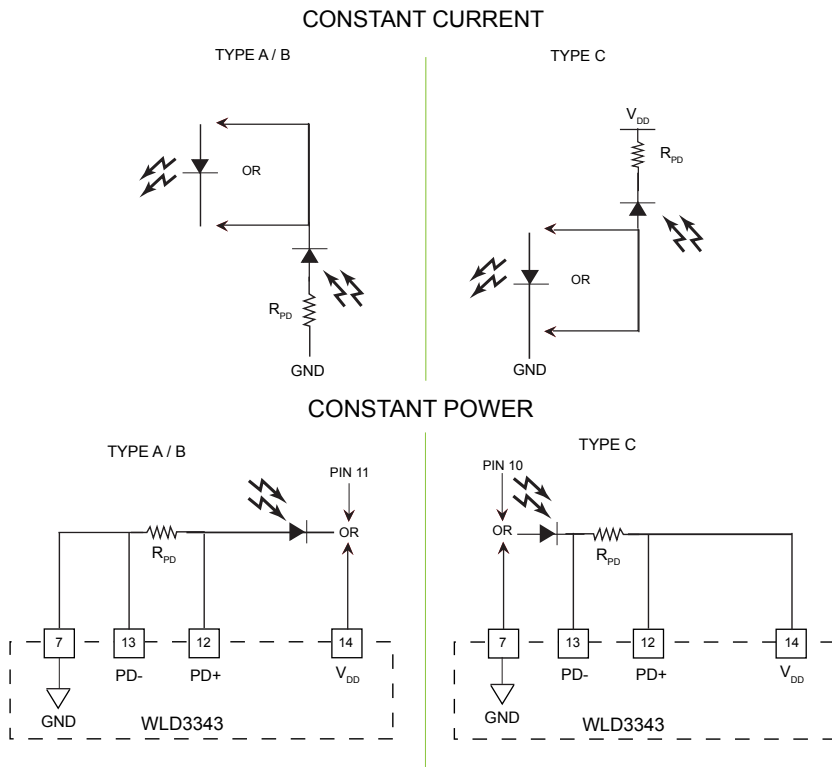

Figure 6. Connecting R_{PD}

HELPFUL HINTS FOR CHOOSING R_{PD}

- Never use a carbon film resistor for R_{PD} .
- Select a resistor with a low temperature coefficient (ppm/ $^{\circ}$ C).
- Place R_{PD} as close to Pins 12 (PD+) and 13 (PD-) on the WLD3343 as possible to avoid parasitic resistance effects from the PCB layout when in Constant Power mode.

Use the online WLD Circuit Calculator to automatically determine values for external components.
www.teamwavelength.com/support/design-tools/wld-calculator/

DISABLING OUTPUT CURRENT

The output current can be enabled and disabled as shown in **Figure 7** using a Single-Pole Single-Throw (SPST) switch or a TTL signal.



DO NOT INSERT OR REMOVE THE LASER DIODE FROM THE WLD3343 CIRCUIT WITH POWER APPLIED TO THE UNIT.

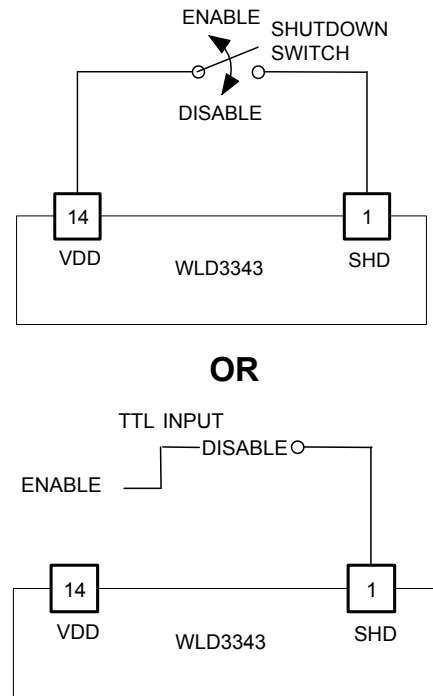
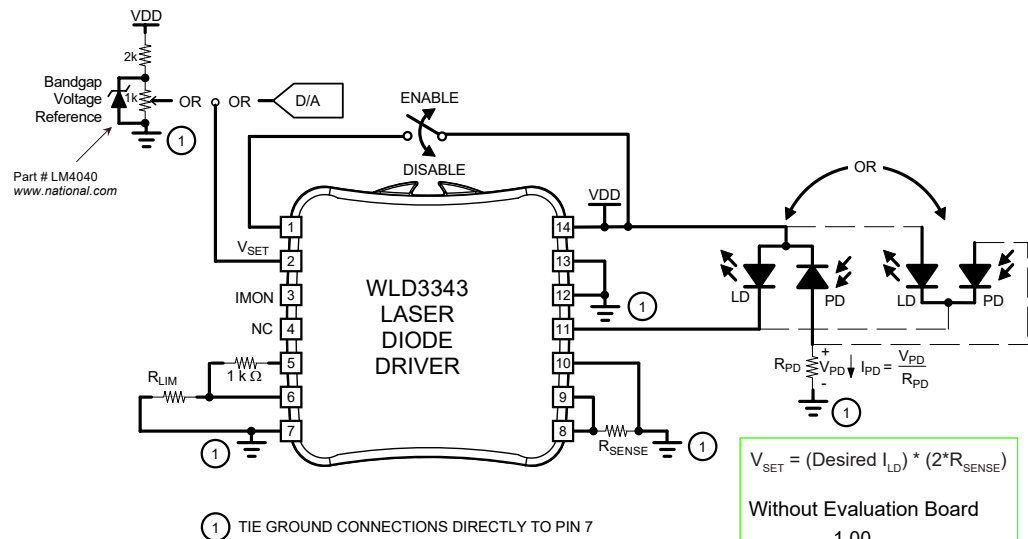

Figure 7. Enable or disable output current.

CONNECTION DIAGRAMS FOR TYPE A/B LASERS

VALUE	DETAILS	VALUE	DETAILS
V _{SET}	Eq. (9) or (10) on page 15	R _{LIM}	Eq. (7) on page 11
IMON	Eq. (11) on page 15	R _{SENSE}	Eq. (3) or (4) on page 10
PMON	Eq. (13) on page 15	R _{PD}	Eq. (8) on page 12

CONSTANT CURRENT:



$$V_{SET} = (\text{Desired } I_{LD}) * (2 * R_{SENSE})$$

Without Evaluation Board

$$R_{SENSE} = \frac{1.00}{I_{LDMAX}}$$

With Eval Board (Rev. Level)

LD Range	R _{SENSE} (Rev. C)	R _{SENSE} (Rev. A&B)
2.0 A	438 mΩ	500 mΩ
200 mA	5.01 Ω	5.1 Ω

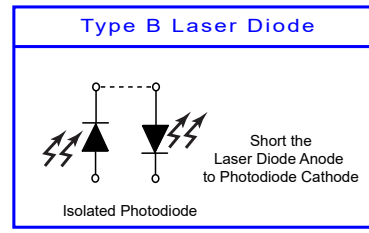
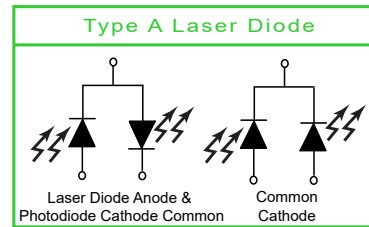

Use the online WLD Circuit Calculator to automatically determine values for external components.

www.teamwavelength.com/support/design-tools/wld-calculator/

Figure 8. Type A/B laser configured for Constant Current operation.

CONSTANT POWER:

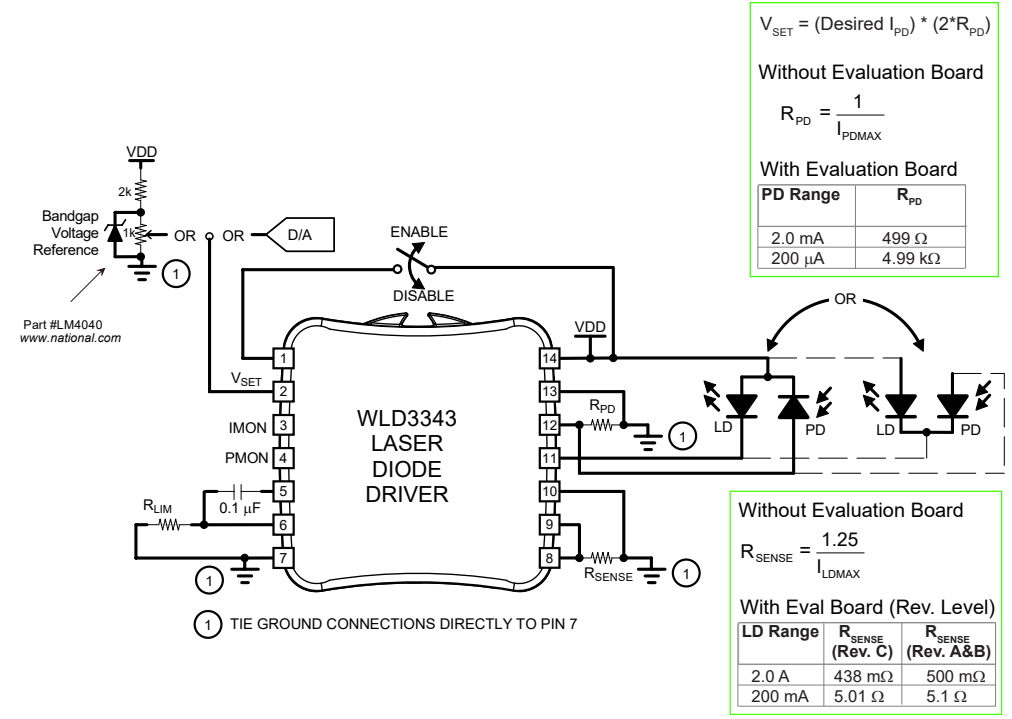

$$V_{SET} = (\text{Desired } I_{PD}) * (2 * R_{PD})$$

Without Evaluation Board

$$R_{PD} = \frac{1}{I_{PDMAX}}$$

With Evaluation Board

PD Range	R _{PD}
2.0 mA	499 Ω
200 μA	4.99 kΩ

Without Evaluation Board

$$R_{SENSE} = \frac{1.25}{I_{LDMAX}}$$

With Eval Board (Rev. Level)

LD Range	R _{SENSE} (Rev. C)	R _{SENSE} (Rev. A&B)
2.0 A	438 mΩ	500 mΩ
200 mA	5.01 Ω	5.1 Ω

Figure 9. Type A/B laser configured for Constant Power operation.

CONNECTION DIAGRAMS FOR TYPE C LASERS

VALUE	DETAILS	VALUE	DETAILS
V _{SET}	Eq. (9) on page 15	R _{LIM}	Eq. (7) on page 11
IMON	Eq. (11) on page 15	R _{SENSE}	Eq. (3) & (4) on page 10
PMON	Eq. (13) on page 15	R _{PD}	Eq. (8) on page 12

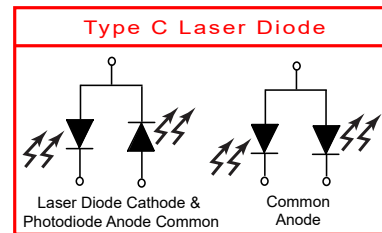

CONSTANT CURRENT:

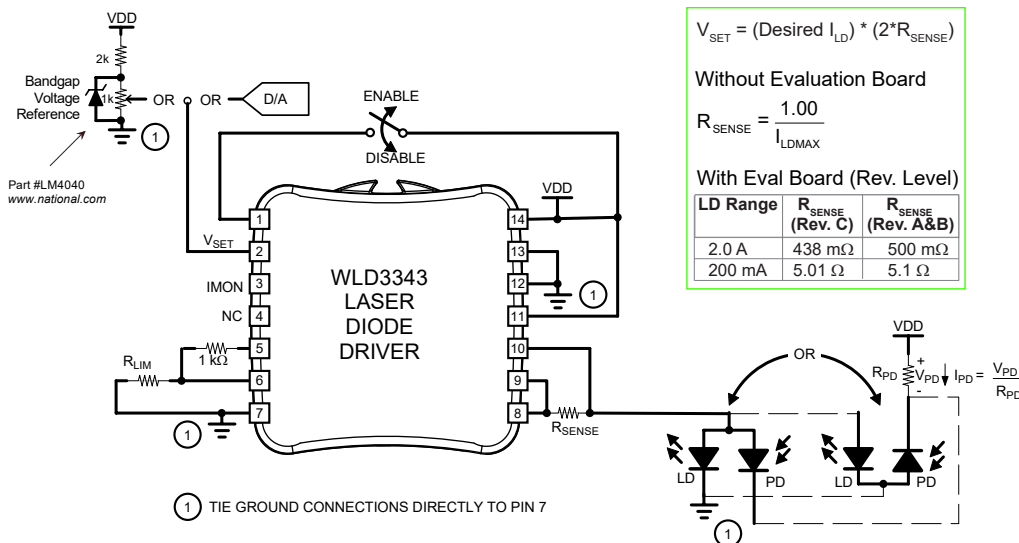

Figure 10. Type C laser configured for Constant Current operation.

CONSTANT POWER:

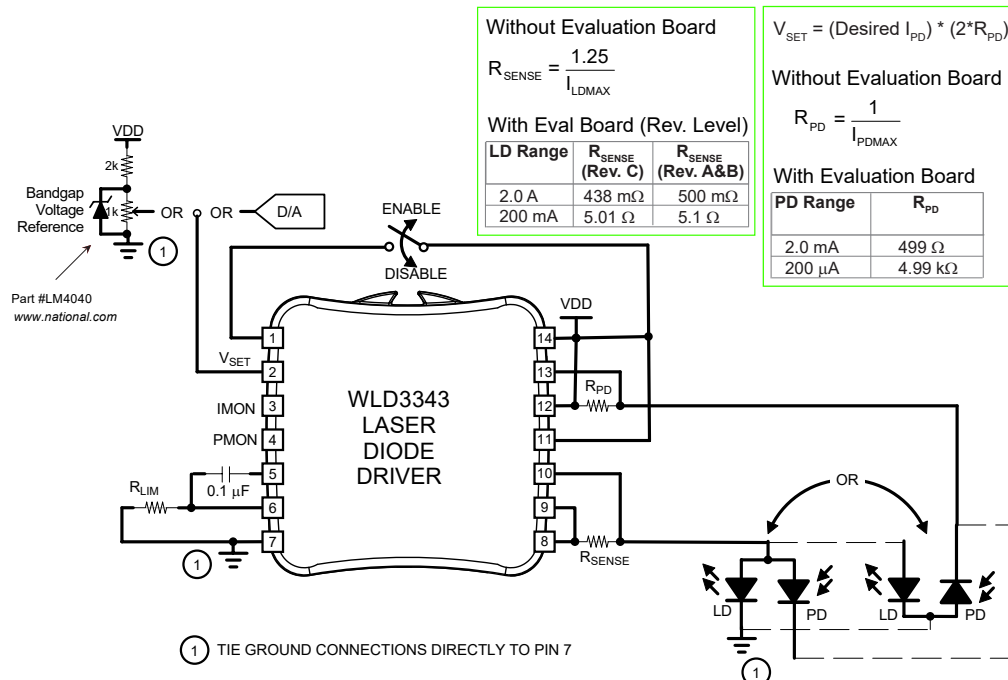

Figure 11. Type C laser configured for Constant Power operation.

UTILIZING V_{SET} (PIN 2)

Pin 2 on the WLD3343, V_{SET} , can be used for externally defining the setpoint, or as a modulation input. **Figure 12** illustrates a typical configuration of the voltage input.



THE AVAILABLE VOLTAGE RANGE FOR V_{SET} IS 0-2 V. CONNECTING VOLTAGES OUTSIDE THIS RANGE CAN RESULT IN DAMAGE TO THE WLD3343 OR THE LASER DIODE.

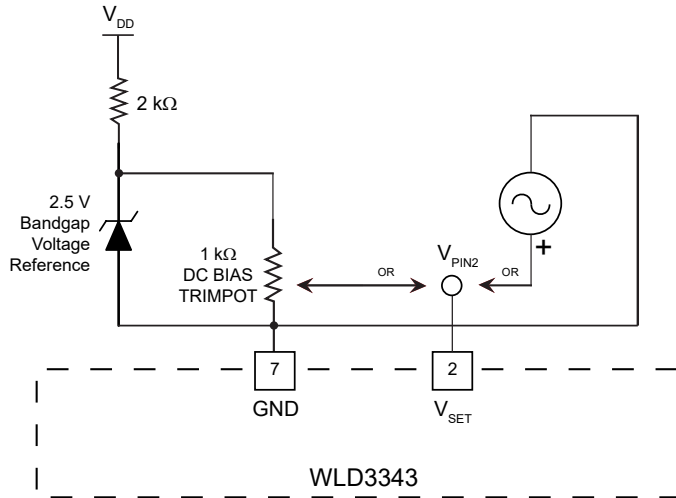

Figure 12. Configuring the voltage input for either a fixed (left) or a modulated (right) voltage setpoint.

For a given voltage supplied to V_{SET} , either the laser diode current will change (Constant Current mode), or the photodiode current will change (Constant Power mode).

Constant Current Mode:

The resulting laser diode current is given by **Equation (9)**.

$$I_{LD} = \frac{V_{PIN2}}{2 \cdot R_{SENSE}} \quad (9)$$

Constant Power Mode:

The resulting photodiode current is given by **Equation (10)**.

$$I_{PD} = \frac{V_{PIN2}}{2 \cdot R_{PD}} \quad (10)$$

MONITORING THE LASER DIODE CURRENT (PIN 3)

Pin 3 (IMON) produces a voltage proportional to the current flowing through the laser diode. **Equation (11)** provides a transfer function for converting the voltage output of Pin 3 to the amount of forward current.

$$I_{LD} = \frac{V_{PIN3}}{2 \cdot R_{SENSE}} \quad (11)$$

MONITORING THE PHOTODIODE CURRENT

The photodiode current is measured differently in Constant Current and Constant Power mode, due to the configurational differences between the modes.

Constant Current Mode:

In Constant Current mode, the photodiode current is measured directly across R_{PD} . **Equation (12)** provides a transfer function for converting this voltage into the corresponding current through the monitor photodiode.

$$I_{PD} = \frac{V_{RPD}}{R_{PD}} \quad (12)$$

Constant Power Mode:

In Constant Power mode, the photodiode current is measured using Pin 4 (PMON). **Equation (13)** provides a transfer function for converting this voltage to the amount of current flowing through the monitor photodiode.

$$I_{PD} = \frac{V_{PIN4}}{2 \cdot R_{PD}} \quad (13)$$

Use the online WLD Circuit Calculator to automatically determine values for external components.

www.teamwavelength.com/support/design-tools/wld-calculator/

OPERATING INSTRUCTIONS – WITH EVALUATION BOARD

SETUP INFORMATION

To set up the WLD3393¹ for your project, you'll need a few pieces of information. Here's a handy list of what you'll need to know before you start wiring. This is also good information if you need technical support.

PARAMETER	VALUE	NOTES
Laser Diode Configuration	A, B, or C	See Figure 3 for schematics. If there is no photodiode, follow instructions for Type A laser diodes.
Power Supply Voltage (5-12 V)		If greater than 5 V, make sure to check the SOA and use a Thermal Solutions kit (fan, heatsink, and thermal washer) or equivalent. HB model requires less voltage.
Laser Diode Max Current		Damage threshold for laser diode.
Operating LD Current		If greater than 200 mA, make sure to check the SOA curve, and use a Thermal Solutions kit (fan, heatsink, and thermal washer) or equivalent.
Operating Mode	CP or CC	CC: Laser diode current is fixed, power varies. CP: Laser diode current varies, photodiode current and power output fixed.
Operating PD Current		Only necessary if output power will be monitored.

Table 7. WLD setup information

Figure 13 gives a top view of the WLD3393 Evaluation Board.

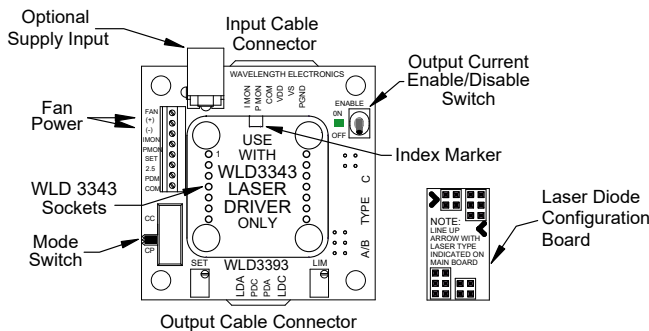

Figure 13. WLD3393 Top View

¹ “Additional Technical Information” on page 22 provides information about using the WLD3393 Evaluation Board with the WLD3343-HB

CONFIGURING THE EVALUATION BOARD

Follow the next eleven steps sequentially to safely operate the WLD with your laser diode. Complete steps 1 through 5 *before* applying power to the board.

STEP 1: DETERMINE WLD3393 OPERATING RANGE

Before proceeding with configuration of the WLD3343 and WLD3393, it is critical that you verify that the driver will be within the Safe Operating Area.



TO ENSURE SAFE OPERATION, IT IS IMPERATIVE THAT YOU DETERMINE IF THE UNIT IS GOING TO BE OPERATING WITHIN THE INTERNAL HEAT DISSIPATION SAFE OPERATING AREA (SOA).

Wavelength recommends using the online SOA Calculators: www.teamwavelength.com/support/design-tools/soa-ld-calculator/

STEP 2: INSTALL THE WLD3343 ON THE EVALUATION BOARD

Match up the notch in the WLD3343 with the index marker shown in **Figure 14**. Align the WLD3343 pins with the WLD3393 sockets, ensuring that all pins are lined up. Press firmly to seat the WLD3343. *Make sure that none of the pins on the WLD3343 were bent during insertion before continuing.*

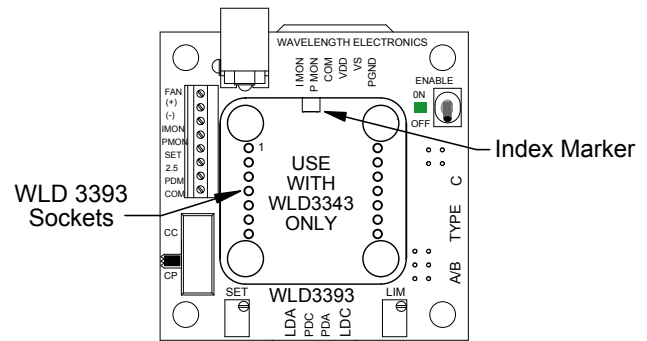

Figure 14. Location of index marker and sockets (top) and standoff assembly (bottom). There are four standoffs provided (4-40 × 0.625”).

STEP 3: CHOOSE OPERATION MODE

The two modes of operation supported by the WLD3393 are Constant Current (CC) and Constant Power (CP):

- In Constant Current mode, V_{SET} correlates directly to the laser diode current, regardless of laser diode power intensity.
- In Constant Power mode, the WLD controls the laser diode using the photodiode to achieve a laser intensity that is directly proportional to V_{SET} .

Prior to applying power to the board, use the Mode Switch to choose either CC or CP. Ensure that the switch is completely rockered to the chosen end.



IT IS VERY IMPORTANT TO CONFIGURE THE WLD3393 FOR THE DESIRED OPERATION MODE BEFORE POWER IS APPLIED. CHANGING OPERATION MODE WHILE THE WLD3393 IS OPERATING CAN RESULT IN DAMAGE TO YOUR LASER DIODE.

STEP 4: CONFIGURE JUMPERS

Jumper positions are shown in **Figure 15**. Factory default locations are noted.

- **LD RANGE Jumper:** Select the laser diode output current range by using the LD RANGE jumper on the back of the WLD3393. The two available options are the “200 mA” or the “2 A” position.
- **PD RANGE Jumper:** Set the PD RANGE jumper on the bottom of the WLD3393 to either the “200 μ A” or the “2 mA” range, depending on the specifications of your photodiode. It is important to make sure that the correct PD current range is selected. If the wrong range is chosen, the WLD3393 may overdrive the laser, resulting in permanent damage to the laser.
- **POWER SELECT Jumper:** The factory default is to separate the V_S and V_{DD} power supply inputs. V_S drives the laser diode while V_{DD} powers the control electronics. You can tie these together instead by moving the Power Select jumper to the “VS+VDD” position. Note that when in this position, V_S on the input connector pin will be at the same potential as the V_{DD} pin.
- **VSET SOURCE Jumper:** The factory default is to use the onboard setpoint trimpot to generate the setpoint voltage (“T” position). To use an external signal, move this jumper to the “X” position.

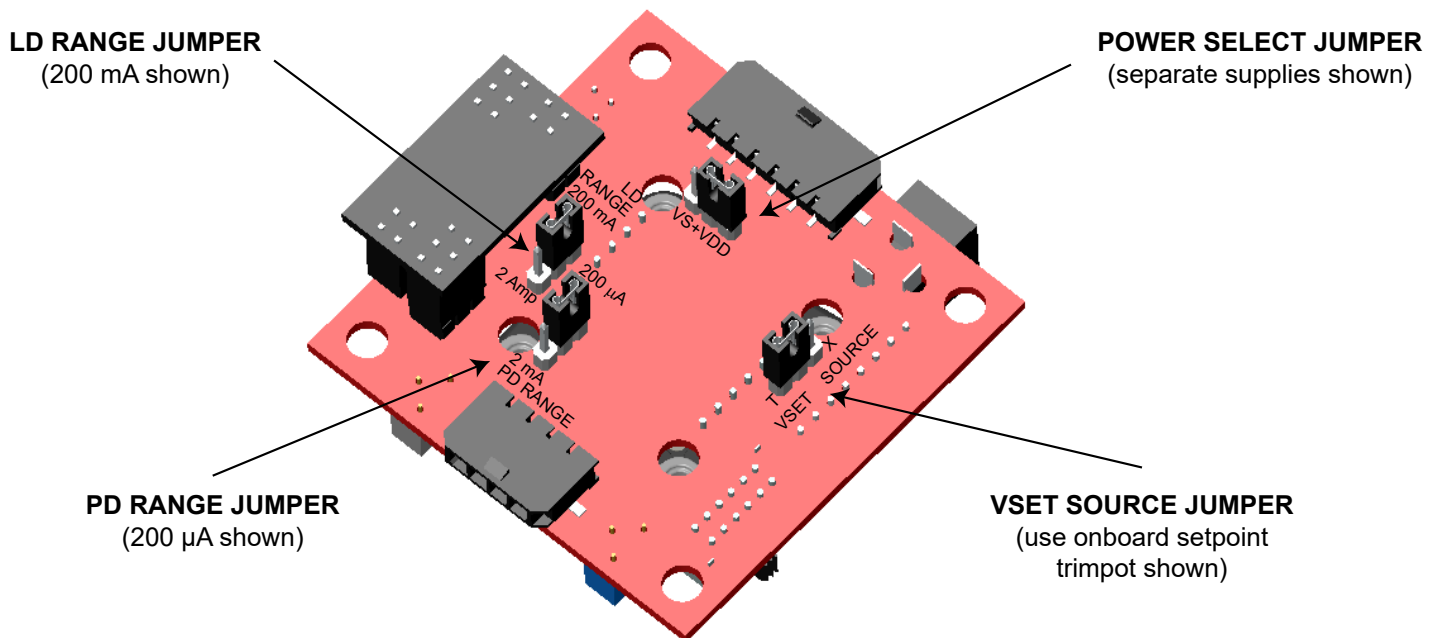

Figure 15. Jumper locations (factory default), bottom view of WLD3393.

STEP 5: INSTALL THE LASER DIODE CONFIGURATION BOARD

To configure the WLD3393 for your laser diode type, connect the configuration board to the bottom of the WLD3393 so that the arrow on the protruding edge of the configuration board points to either A/B or C. Refer to **Figure 16** for Type A/B example installation, and **Figure 17** for Type C example installation.

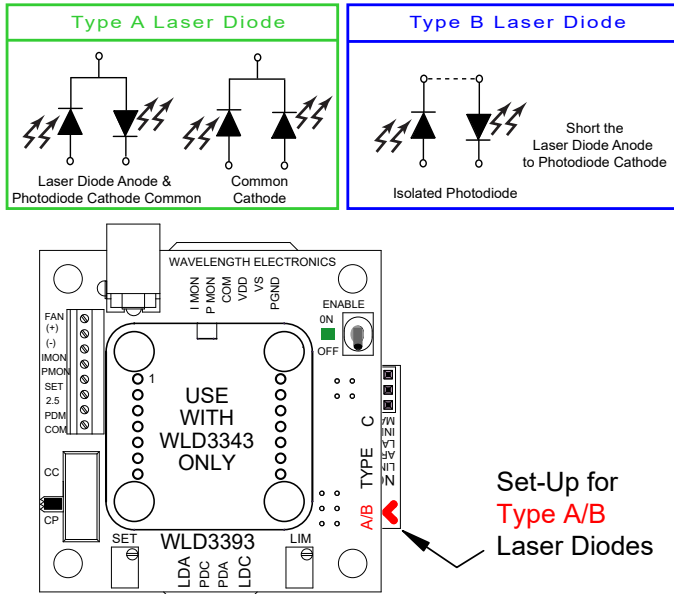

Figure 16. Proper installation of the configuration card for Type A/B lasers.

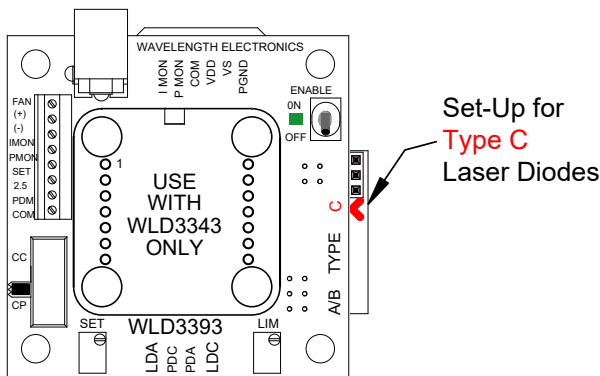
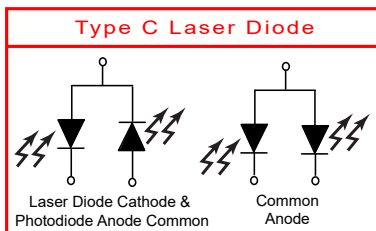

Figure 17. Proper installation of the configuration card for Type C lasers.



IF THE WLD3393 IS CONFIGURED INCORRECTLY FOR THE TYPE OF LASER DIODE YOU ARE USING, DAMAGE CAN RESULT TO YOUR LASER DIODE AND/OR THE WLD3393.

STEP 6: ATTACH THE HEATSINK AND FAN

This step is optional for less than +5 V, 500 mA operation.

- **Heatsink Requirements:**
 - » Attach a heatsink (WHS302) when the WLD3343 will operate between 500 mA and 1.0 A output current.
 - » Attach a fan (WXC303 for +5 VDC or WXC304 for +12 VDC) to the heatsink for output currents exceeding 1.0 A.
 - » If using Wavelength accessories, refer to the WHS302, WTW002, WXC303, and/or the WXC304 datasheets for assembly instructions.
- **Fan Connections:** Connect the fan leads to the (+) and (-) fan power positions on the terminal block and secure with a small flat head screwdriver. The fan connects to the V_{DD} supply, not V_S , so care must be exercised to ensure that the proper fan is selected, either +5 VDC or +12 VDC, when using dual power supplies. Optionally, for lower noise operation, the fan leads may be connected directly to a separate power supply compatible with the fan.

STEP 7: ATTACH THE V_{DD} AND V_S POWER SUPPLIES

The WLD3393 has two power supply connections:

- V_S
 - » provides power for driving the laser (minimum current capacity greater than limit current setting).
 - » can range from +4.5 to +12 V (except for HB models, must be between +3.3 V and +6 V).
- V_{DD}
 - » provides power to the control electronics (minimum 100 mA).
 - » can range from +5 to +12 V (except for HB models, must be between +3.3 V and +6 V).

V_S and V_{DD} can be connected for simple operation using the Power Select Jumper. See Step 4 for location.

A separate V_S power supply allows the output current stage to operate below the minimum 5 V required for the control electronics or up to the +12 V maximum (for multiple laser diodes in series). Select V_S approximately 2.0 V above the maximum voltage drop across the laser diode to reduce the power dissipation in the WLD3343 component and minimize your heatsinking requirements. *Note that for Type C laser diodes in Constant Power mode, V_{DD} must be greater than or equal to V_S to keep the photodiode signal in range.*

Use PGND for the power return. The common (COM) terminal on the WLD3393 is not intended to act as a power connection, but as the low noise ground reference for connecting an external VSET source, and for monitoring the IMON, PMON, and PDM signals.

The 2.5 mm input power jack attaches to V_{DD} . You can use the Wavelength PWRPAK power supplies with this jack. Use either the power jack or the power inputs on the connector harness, not both.

STEP 8: SET THE LASER DIODE CURRENT LIMIT

The WLD3393 LIM trimpot adjusts the laser diode current limit from zero to the full 200 mA or 2.2 A, depending on the laser diode current range selected. For accurate laser diode current limit configuration, follow these steps sequentially:

A) Connect a test load across the LDA and LDC terminals of the WLD3393. See **page 3** for test load information.

Connect a voltmeter across the test load. This voltmeter will be used to monitor the output current while setting the current limit. Refer to the datasheet for your laser diode and find the manufacturer’s recommended current limit (I_{LIMIT}), then calculate the corresponding voltage limit, V_{LIMIT} with **Equation (14)**.

$$V_{LIMIT} = I_{LIMIT} \cdot R_{LOAD} \quad (14)$$

B) Configure the evaluation board for Constant Current (CC) operation using the Mode Switch.

C) Turn the SET trimpot at least twelve turns counter-clockwise (OFF). Adjust the LIM trimpot at least twelve turns clockwise (ON).

D) Apply power to the WLD3393 and enable the output current by switching the enable switch to the “ON” position. See **Figure 13** to locate the switch.

E) Adjust the SET trimpot clockwise until the voltmeter displays V_{LIMIT} calculated in **Equation (14)**. Next, turn the LIM trimpot counter-clockwise until the displayed voltage just begins to decrease. Finally, turn the SET trimpot fully counter-clockwise to zero the output current.

F) Disable the output current by switching the enable switch to the “OFF” position. Remove power from the WLD3393.

G) Return the Mode Switch to CC or CP, according to your application.

STEP 9: CONNECT THE LASER DIODE AND MONITOR PHOTODIODE

With power removed from the WLD3393 board, connect the output (4 wire cable) to your laser diode as indicated in **Table 8**. Firmly press the output cable into the output connector.

PIN #	WIRE COLOR	FUNCTION
1	Red	LDA
2	Green	PDC
3	White	PDA
4	Black	LDC

Table 8. Output cable color code.

A Molex 4-pin housing (43645-0400) is the plug used for the output cable.

STEP 10: MONITOR THE LASER DIODE AND PHOTODIODE CURRENTS

IMON, PMON, and PDM allow for monitoring of laser diode current and power intensity, depending on the selected mode of operation. All three can be found on the terminal block. IMON and PMON are duplicated on the input cable (pinout in **Table 9**). The voltages at IMON, PMON, and PDM are all referenced to the common terminal (COM) on the input connector or the terminal block. A Molex 6-pin housing (43645-0600) is the plug used for the input cable.

PIN #	WIRE COLOR	FUNCTION
1	Blue	PGND
2	Orange	VS
3	Red	VDD
4	Black	COM
5	White	PMON
6	Green	IMON

Table 9. Input Cable Color Code

- IMON provides a mechanism for externally monitoring the laser diode current. IMON is available at all times in both CC and CP modes. See **Table 10** for IMON transfer functions.
- PMON provides an external indication of the laser diode intensity by measuring photodiode current. Since PD+ and PD- on the WLD3343 are shorted together in CC mode, PMON will only monitor photodiode current in CP mode. See **Table 11** for PMON transfer functions
- PDM provides a mechanism for monitoring photodiode current in either CC or CP mode. While PMON monitors the feedback used by the control electronics to maintain constant power of the laser, PDM is an external monitor that is independent of the control electronics of the WLD3343. The transfer functions for PDM are the same as PMON. PDM is accessible on the terminal block.

FUNCTION	MODE	200 mA RANGE	2 A RANGE
IMON	CC / CP	106 mA / V	1.2 A / V
VSET	CC	106 mA / V	1.2 A / V

Table 10. WLD3393 laser diode current transfer functions. Convert IMON and VSET voltage to laser diode current.

FUNCTION	MODE	200 μ A RANGE	2 mA RANGE
PMON	CP	100 μ A / V	1 mA / V
PDM	CC / CP	100 μ A / V	1 mA / V
VSET	CP	100 μ A / V	1 mA / V

Table 11. WLD3393 photodiode current transfer functions. Convert PMON, PDM, or VSET voltage to photodiode current.

STEP 11: ADJUST THE SETPOINT VOLTAGE

The setpoint controls the output of the WLD3343. The setpoint voltage can be adjusted using the onboard SET trimpot, applying an external setpoint voltage, or by summing the two signals. The VSET SOURCE jumper must be properly configured for the chosen method (see **Figure 15** for its location). The sum of the external setpoint voltage and the SET trimpot voltage can be adjusted from 0 to 2.5 V. The transfer functions relating the VSET voltage to the laser diode or photodiode current are given in **Table 10** and **Table 11**, respectively.

To use only the onboard SET trimpot, place the VSET SOURCE jumper to the "T" position, and do not connect an external voltage source to the SET terminal on the terminal block. The SET trimpot will allow the setpoint to be adjusted from 0 to 2.5 V.

To use an external voltage source summed with the setpoint voltage from the onboard SET trimpot, place the VSET SOURCE jumper to the "T" position. Connect an external voltage source to the SET terminal on the terminal block. The resulting setpoint voltage will be the sum of the voltage dialed in using the SET trimpot, and the voltage applied to the SET terminal.

To use only an external voltage source for the setpoint, place the VSET SOURCE jumper to the "X" position and connect the external setpoint voltage source to the SET terminal on the terminal block. When the VSET SOURCE jumper is in the "X" position, the voltage of the SET trimpot on the WLD3393 is ignored.

If an external voltage source is not available, but setpoint adjustment needs to be external, a remotely located potentiometer can easily be connected to the WLD3393 to adjust the setpoint. Connect the clockwise lead of the potentiometer to the terminal position marked 2.5 on the terminal block. Connect the counter-clockwise lead to the COM terminal and connect the wiper to the SET terminal and ensure that the VSET SOURCE jumper on the bottom of the board is set to the "X" position. See **Figure 18** for external potentiometer wiring.

NOTE: The 2.5 V output can source 1.5 mA with a 5 V input. Use greater than 2 k Ω resistance to prevent it loading down.

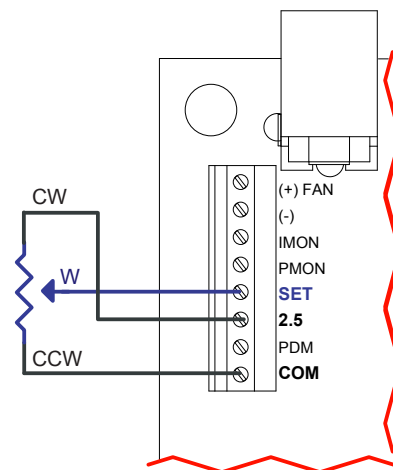

Figure 18. External setpoint adjustment.

STEP 12: ENABLE OR DISABLE THE OUTPUT CURRENT

The WLD3343 output current can be enabled and disabled using the onboard toggle switch. The output is enabled when the green ON LED indicator is lit (see **Figure 13**).

You can also remotely enable the WLD3343 by connecting a control signal to a via (See **Figure 19**). This is an active low input. GND = ENABLE. Note the ON/OFF LED will not light when enabled using the remote input.

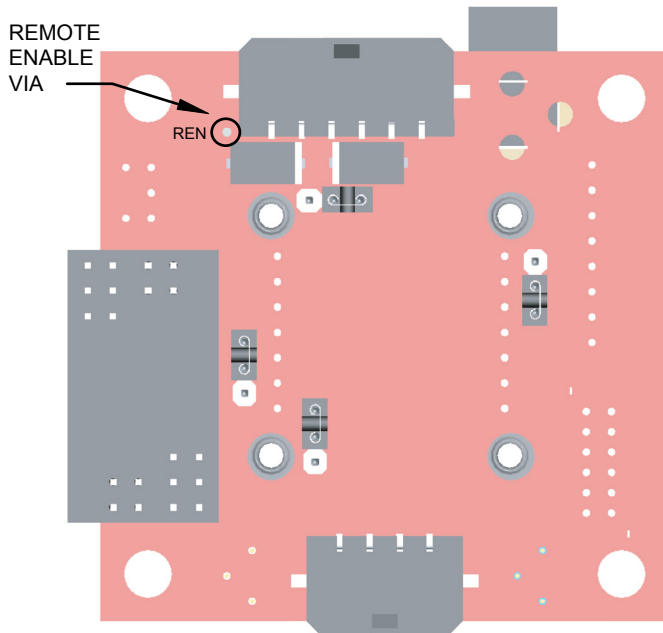

Figure 19. Control signal via placement.

ADDITIONAL TECHNICAL INFORMATION

This section includes useful technical information on these topics:

- **Noise Reduction**
- **Improve Temperature Coefficient with the WLD3393 Evaluation Board**
- **Using the WLD3343HB with the WLD3393 Evaluation Board**
- **Bandwidth Optimization with the WLD3393 Evaluation board**
- **Thermal Management Kits**
- **Prior Revision of the WLD3393 Evaluation Board**
- **Safe Operating Area Calculation**
- **WLD3393 Evaluation Board Schematic**

NOISE REDUCTION

For lowest noise, operate in Constant Current mode with the cathode of the laser diode grounded (Type C).

If you buy a special low-noise version of the WLD3343 (WLD3343-2L, or WLD3343-3L for 3 A output), you can decrease noise by a factor of 2.5 under the same conditions. Note that you can only operate in Constant Current mode with the WLD3343-2L and WLD3343-3L.

IMPROVE TEMPERATURE COEFFICIENT WITH THE WLD3393 EVALUATION BOARD

To achieve better stability, use the external setpoint input rather than the onboard setpoint trimpot.

USING THE WLD3343HB WITH THE WLD3393 EVALUATION BOARD

To operate with 3.3 V input, use the WLD3343HB. Note that maximum output current at this supply voltage is 170 mA (200 mA range) or 1.7 A (2 A range).

BANDWIDTH OPTIMIZATION WITH THE WLD3393 EVALUATION BOARD

To improve bandwidth, shorten the cables. Expect 1.8 MHz at 200 mA and 850 kHz at 2 A (sine wave 3 dB point) with factory-length cables.

POWER SUPPLIES AND NOISE

The WLD drivers deliver stable current with low noise, but the chosen power supply will directly influence the noise performance of the driver.

We recommend using a regulated linear power supply for the best noise performance, but depending on the application requirements, a switching power supply may be acceptable. Each case must be evaluated, because a switching power supply will affect noise, transient, and stability performance.

Wavelength offers several switching power supplies that may be appropriate.

MODEL	MAX VOLTAGE	MAX CURRENT
PWRPAK-5V	5 V	8 A
PWRPAK-7V	7 V	3 A
PWRPAK-9V	9 V	3 A
PWRPAK-12V	12 V	2.5 A

Table 12. Available power supplies.

THERMAL MANAGEMENT KITS

The WLD Series of laser diode drivers have customized thermal kits available. Available kits are:

- WEV300, includes
 - » WTW002 thermal washer
 - » WHS302 heatsink
 - » WXC305 screw kit
- WEV301, includes
 - » WTW002 thermal washer
 - » WHS302 heatsink
 - » WXC303 +5 V fan
 - » WXC305 screw kit
- WEV302, includes
 - » WTW002 thermal washer
 - » WHS302 heatsink
 - » WXC304 +12 V fan
 - » WXC305 screw kit

PRIOR REVISION OF THE WLD3393 EVALUATION BOARD

The prior revision of the WLD3393 was black. That revision's datasheet is available here:

www.teamwavelength.com/download/Datasheets/wld3393b.pdf

SAFE OPERATING AREA CALCULATION

The Safe Operating Area of the WLD driver is determined by the amount of power that can be dissipated within the output stage of the driver. If that power limit is exceeded, permanent damage can result.



DO NOT OPERATE THE WLD DRIVER OUTSIDE OF THE SAFE OPERATING AREA CURVE.

OPERATING THE WLD DRIVER OUTSIDE OF THE SOA VOIDS THE WARRANTY.

Refer to the Wavelength Electronics website for the most up-to-date SOA calculator for our products. The online tool is fast and easy to use, and also takes into consideration operating temperature.

www.teamwavelength.com/support/design-tools/soa-ld-calculator

SOA charts are included here for quick reference, however we recommend you use the online tools instead.

Follow these steps to determine if the driver will be operating within the SOA.

- Refer to the laser diode datasheet to find the maximum voltage (V_{MAX}) and current (I_{MAX}) specifications
- Calculate the voltage drop across the controller:

$$V_{DROP} = V_S - V_{MAX}$$
 (V_S is the power supply voltage)
- Mark V_{DROP} on the X-axis, and extend a line upward
- Mark I_{MAX} on the Y-axis, and extend a line to the right until it intersects the V_{DROP} line
- On the X-axis, mark value of V_S
- Extend a diagonal line from V_S to the intersection of the V_{DROP} and I_{MAX} lines; this is the Load Line
- If the Load Line crosses the Safe Operating Area line at any point, the configuration is not safe

If the SOA Calculator indicates the WLD will be outside of the Safe Operating Area, the system must be changed so that less power is dissipated within the driver. See Wavelength Electronics Application Note [AN-LDTC01: The Principle of the Safe Operating Area](#) for information on shifting the Load Line.

After changing any of the operating parameters, recalculate the SOA to make sure the driver will operate safely. If you have questions, or run into difficulties calculating the SOA, contact Wavelength Electronics for assistance.

WLD3343 SOA CHART:

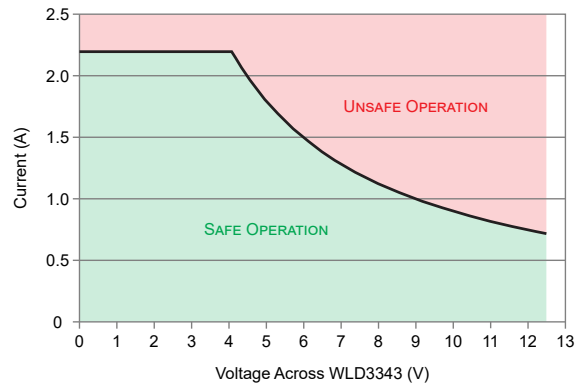

Figure 20. SOA for WLD3343 with thermal washer, heatsink, and fan.

WLD3343HB SOA CHART:

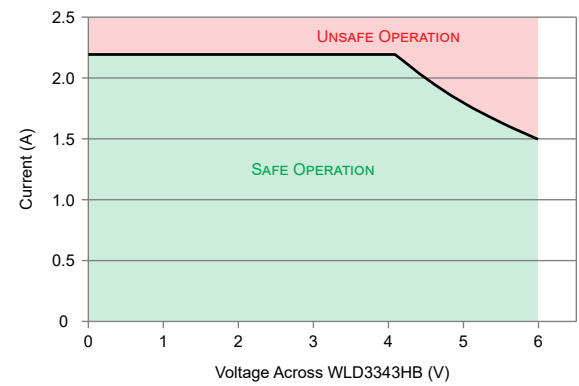

Figure 21. SOA for WLD3343HB with thermal washer, heatsink, and fan.

WLD3343-3A SOA CHART:

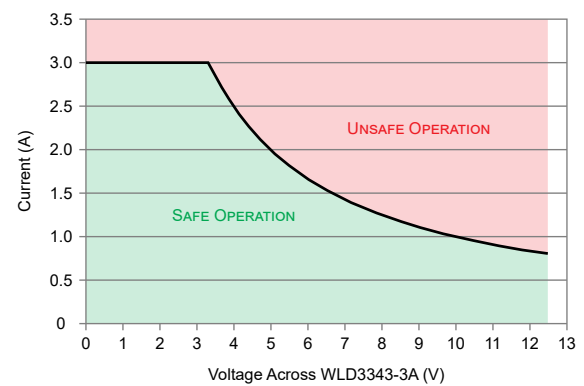

Figure 22. SOA for WLD3343-3A with thermal washer, heatsink, and fan.

WLD3393 EVALUATION BOARD SCHEMATIC

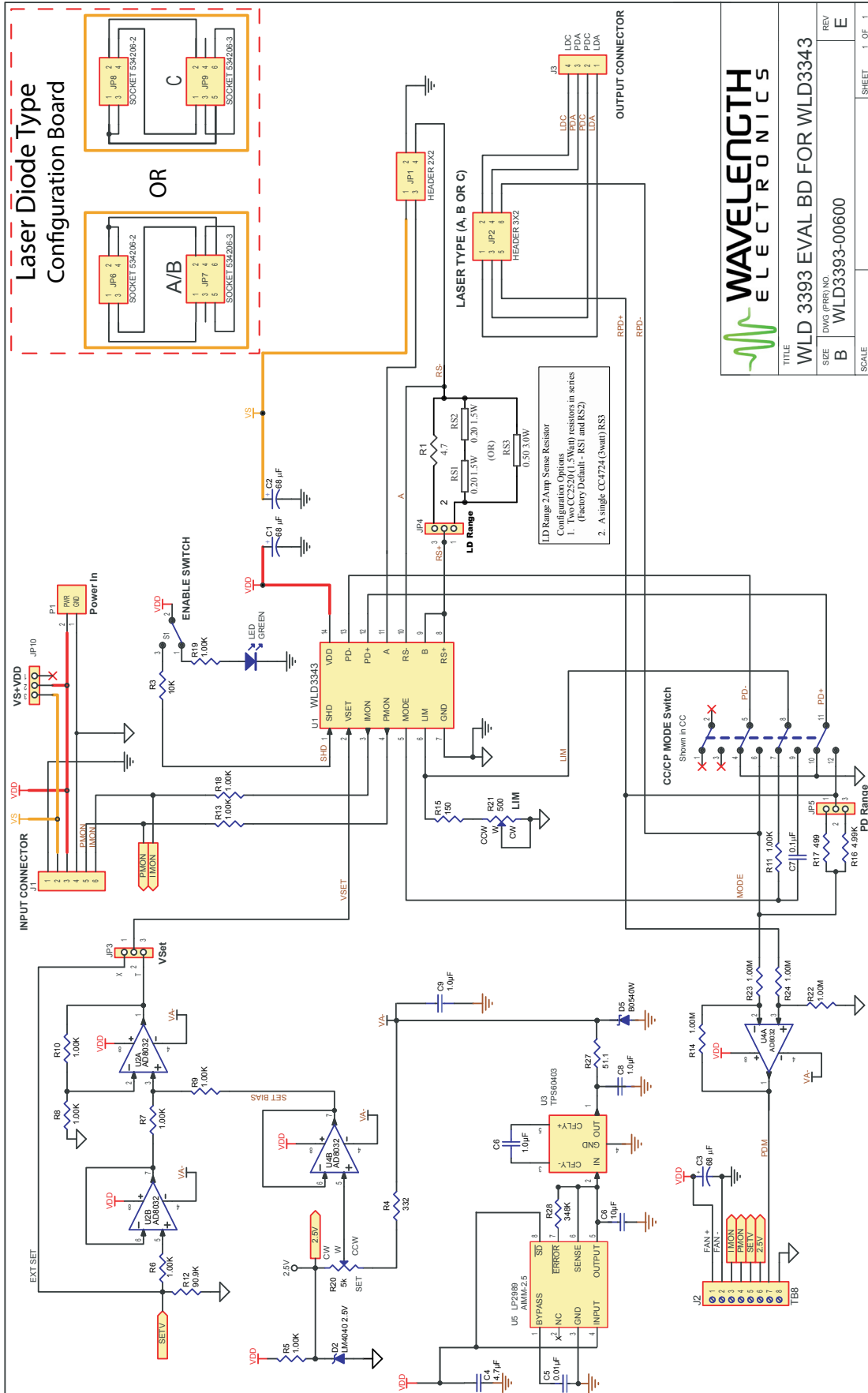

Figure 23. WLD3393 evaluation board schematic.

TROUBLESHOOTING

PROBLEM	POTENTIAL CAUSES	SOLUTIONS
Driver will not switch on	Improperly configured power supply	<i>Standalone:</i> Carefully check the wiring diagram according to page 13 and page 14 . <i>Evaluation Board:</i> See page 18 for details regarding power supply connections.
Output will not enable	ENABLE pin not held low	<i>Standalone:</i> Refer to the SHD pin specifications in Table 1 and make sure this pin is held at zero volts or left floating. <i>Evaluation Board:</i> Ensure that the ENABLE switch is fully rockered to the ON position.
Laser output power too low in Constant Current mode	Laser current setpoint too low	Increase the setpoint by increasing the voltage at Pin 2 (V_{SET}). <i>Evaluation Board:</i> The setpoint can be increased using the onboard SET trimpot, and/or using the SET input on the terminal strip.
	Laser current limit too low	<i>Standalone:</i> Refer to page 11 for instructions on setting the laser driver current limit. <i>Evaluation Board:</i> Refer to page 19 for instructions on setting the laser driver current limit.
	Laser driver is compliance limited	Check the laser diode specifications to determine the forward voltage (V_f). Make sure that the WLD is not compliance limited. Refer to the Electrical Specifications table on page 6 . If the driver is compliance limited, V_{DD} may need to be increased. Verify that the WLD will be operating within the Safe Operating Area if V_{DD} is increased.
Laser does not reach desired output in Constant Power mode	Photodiode feedback current is out of range for the WLD	Refer to the laser diode datasheet to determine the approximate photodiode (PD) current at the desired output power level. If the PD current exceeds the chosen WLD photodiode current range, either: <i>Standalone:</i> see page 12 for instructions on how to properly set the photodiode current range by choosing R_{PD} . <i>Evaluation Board:</i> see page 17 for instructions on how to increase the PD RANGE jumper value.
Modulation is not working	V_{SET} improperly configured	<i>Standalone:</i> See page 15 for details for modulating using V_{SET} . <i>Evaluation Board:</i> See page 20 for proper evaluation board configuration for modulation.
Cannot zero the trimpots		<i>Evaluation Board:</i> The trimpots that are installed on the WLD3393 are 12-turn trimpots. This means that after 12 full turns counterclockwise, they will be set to zero, even though they will turn continuously.
Photodiode feedback is inaccurate	Improperly configured R_{PD} or PD RANGE jumper	<i>Standalone:</i> see page 12 for instructions on how to properly choose the photodiode current range by choosing R_{PD} . <i>Evaluation Board:</i> see page 17 for instructions on how to change the PD RANGE jumper value.
Transfer functions are inaccurate	Improperly configured CC/CP Mode	If CC/CP Mode is improperly configured, this can lead to inaccuracies in the transfer functions. <i>Standalone:</i> See page 13 or page 14 for proper wiring diagrams. <i>Evaluation Board:</i> Make sure the MODE switch is fully rockered to the desired operating mode.

MECHANICAL SPECIFICATIONS

WLD3343 LASER DIODE DRIVER

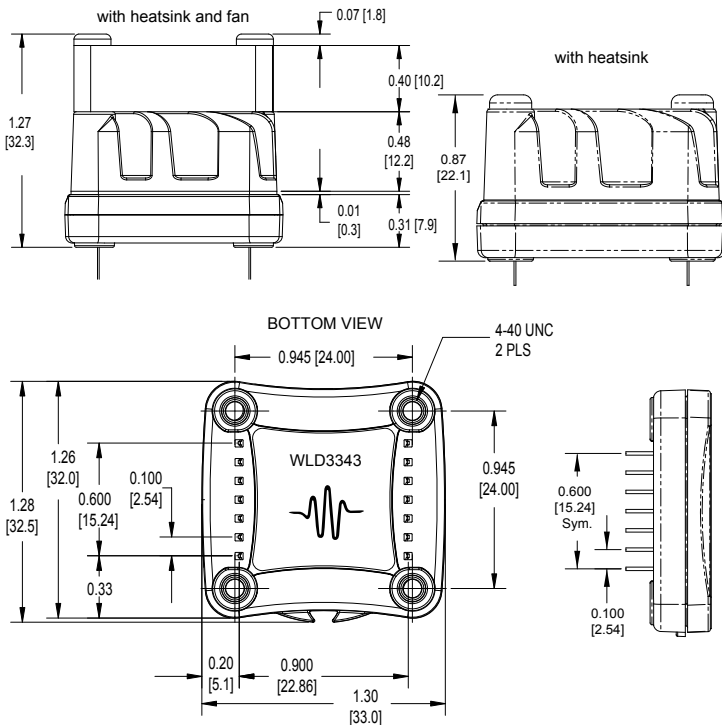

WEIGHTS

WLD3343	0.6 oz
WHS302 Heatsink	0.5 oz
WXC 303/4	0.3 oz

- PIN DIAMETER: 0.020"
- PIN LENGTH: 0.157" ±12%
- PIN MATERIAL: Nickel Plated Steel
- HEAT SPREADER: Nickel Plated Aluminum
- PLASTIC COVER: LCP Plastic
- ISOLATION: 1200 VDC any pin to case
- THERMAL WASHER: WTW002
- HEATSINK: WHS320
- FANS: WXC303 (+5 VDC) or WXC304 (+12 VDC)

PCB FOOTPRINT

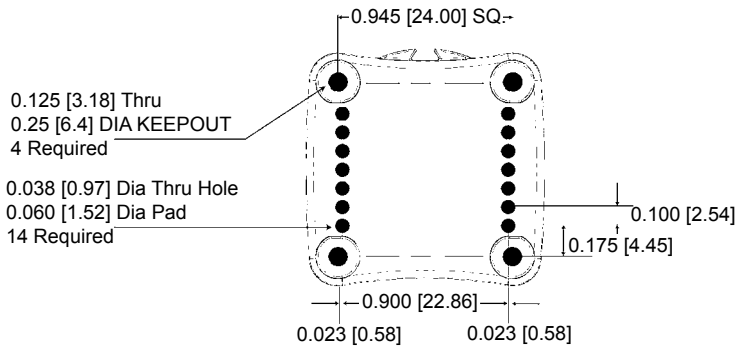

The WLD3343 can be directly soldered to a PCB or installed in a socket soldered to the PCB. Two 7-pin SIP sockets are required. Wavelength recommends Aries Electronics, PN 25-0513-10.

WLD3343 ASSEMBLED WITH HEATSINK & FAN

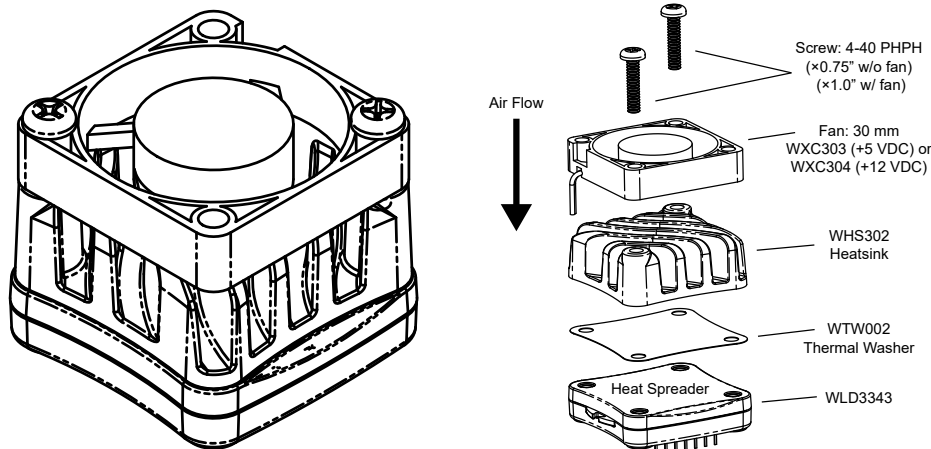

Actual fan wire configuration may be different than shown.

Fan can be rotated on the WLD so the location of the wires matches your PCB layout.

All Tolerances ±5% unless noted; units in inches [mm]

WLD3393 EVALUATION BOARD

CABLE	PLUG
Input	Molex #43645-00600
Output	Molex #43645-00400

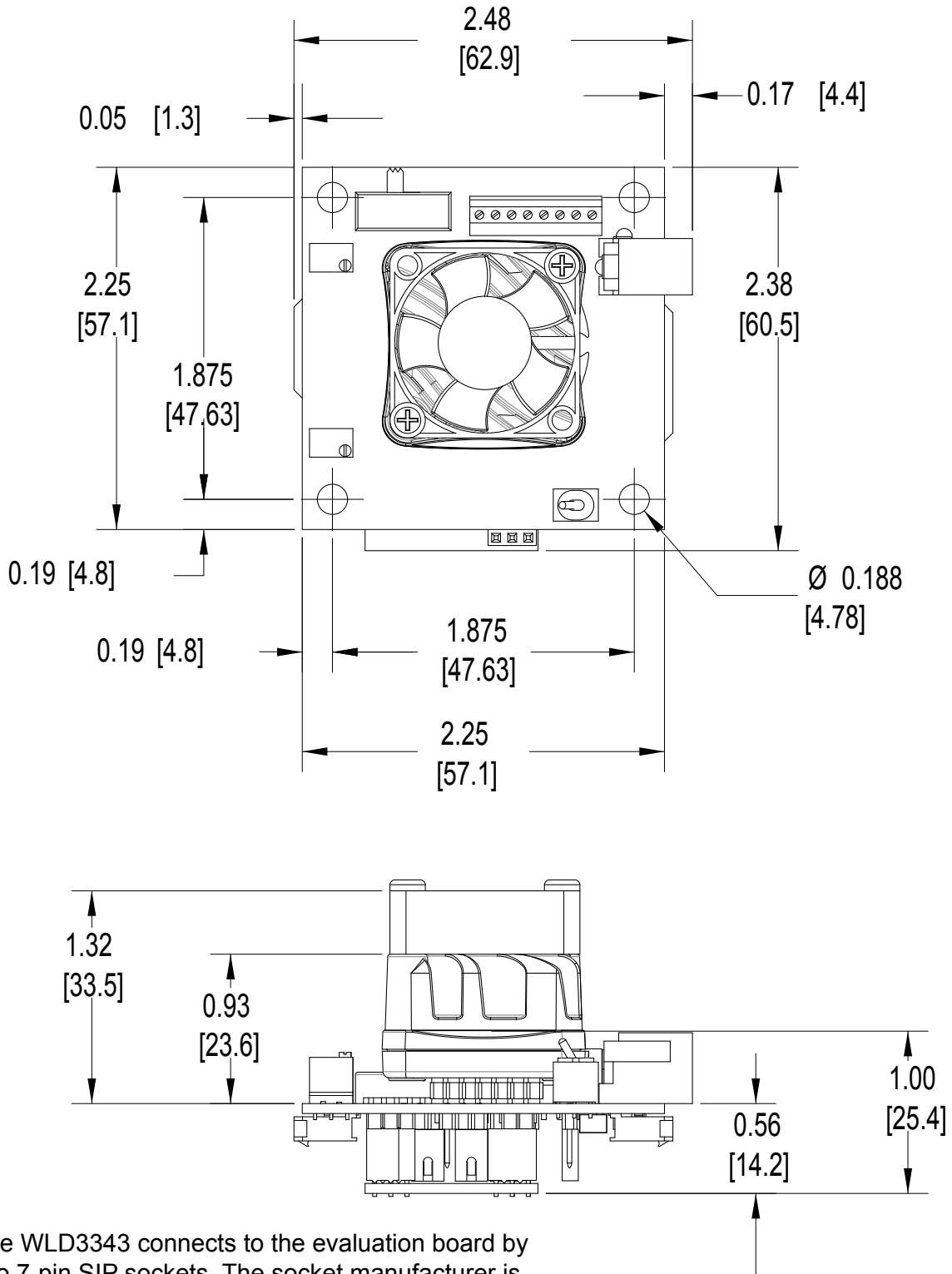

The WLD3343 connects to the evaluation board by two 7-pin SIP sockets. The socket manufacturer is Aries Electronics, PN 25-0513-10.

All Tolerances $\pm 5\%$; units in inches [mm]

CERTIFICATION AND WARRANTY

CERTIFICATION

Wavelength Electronics, Inc. (Wavelength) certifies that this product met its published specifications at the time of shipment. Wavelength further certifies that its calibration measurements are traceable to the United States National Institute of Standards and Technology, to the extent allowed by that organization's calibration facilities, and to the calibration facilities of other International Standards Organization members.

WARRANTY

This Wavelength product is warranted against defects in materials and workmanship for a period of one (1) year from date of shipment. During the warranty period, Wavelength will, at its option, either repair or replace products which prove to be defective.

WARRANTY SERVICE

For warranty service or repair, this product must be returned to the factory. An RMA is required for products returned to Wavelength for warranty service. The Buyer shall prepay shipping charges to Wavelength and Wavelength shall pay shipping charges to return the product to the Buyer upon determination of defective materials or workmanship. However, the Buyer shall pay all shipping charges, duties, and taxes for products returned to Wavelength from another country.

LIMITATIONS OF WARRANTY

The warranty shall not apply to defects resulting from improper use or misuse of the product or operation outside published specifications. No other warranty is expressed or implied. Wavelength specifically disclaims the implied warranties of merchantability and fitness for a particular purpose.

EXCLUSIVE REMEDIES

The remedies provided herein are the Buyer's sole and exclusive remedies. Wavelength shall not be liable for any direct, indirect, special, incidental, or consequential damages, whether based on contract, tort, or any other legal theory.

REVERSE ENGINEERING PROHIBITED

Buyer, End-User, or Third-Party Reseller are expressly prohibited from reverse engineering, decompiling, or disassembling this product.

NOTICE

The information contained in this document is subject to change without notice. Wavelength will not be liable for errors contained herein or for incidental or consequential damages in connection with the furnishing, performance, or use of this material. No part of this document may be translated to another language without the prior written consent of Wavelength.

SAFETY

There are no user-serviceable parts inside this product. Return the product to Wavelength Electronics for service and repair to ensure that safety features are maintained.

LIFE SUPPORT POLICY

This important safety information applies to all Wavelength electrical and electronic products and accessories:

As a general policy, Wavelength Electronics, Inc. does not recommend the use of any of its products in life support applications where the failure or malfunction of the Wavelength product can be reasonably expected to cause failure of the life support device or to significantly affect its safety or effectiveness. Wavelength will not knowingly sell its products for use in such applications unless it receives written assurances satisfactory to Wavelength that the risks of injury or damage have been minimized, the customer assumes all such risks, and there is no product liability for Wavelength. Examples of devices considered to be life support devices are neonatal oxygen analyzers, nerve stimulators (for any use), auto-transfusion devices, blood pumps, defibrillators, arrhythmia detectors and alarms, pacemakers, hemodialysis systems, peritoneal dialysis systems, ventilators of all types, and infusion pumps as well as other devices designated as "critical" by the FDA. The above are representative examples only and are not intended to be conclusive or exclusive of any other life support device.

REVISION HISTORY

DOCUMENT NUMBER: WLD3343-00400

REV.	DATE	CHANGE
Q	February 2017	Clarified R _{SENSE} for 3 A models
R	September 2018	Combined WLD3343, WLD3343-HB, and WLD3393 datasheets
S	March 2019	Added washability specification, updated pin length & tolerance.



WAVELENGTH
E L E C T R O N I C S

51 Evergreen Drive
Bozeman, Montana 59715

406-587-4910 (tel)
406-587-4911 (fax)

Sales & Tech Support
sales@teamwavelength.com
techsupport@teamwavelength.com