



**MAIMAN
ELECTRONICS**

SF8025 ' / (
SF8075 ' / (
SF8150 ' / (

Laser Diode Driver with TEC Controller for
Butterfly LD Type 1 Pump (μ-i' (i'ioæ©' (

Datasheet

1. Laser diode driver features

- Constant current mode
- Low current ripple $\leq 10\mu\text{A}$
- Current stability 0.1%
- No need to adjust voltage
- Soft-start
- Adjustable current limit
- Reverse current protection
- Crowbar circuit protection
- Own software

2. Applications

- Supplying laser diodes in butterfly case

5. Description

SF8xxx contains a laser diode driver and a temperature controller (TEC).

Laser diode driver is a non isolated low drop out (LDO) regulator with constant current output. Driver produces high stability and low ripple current.

TEC is a non isolated DC/DC. TEC produces low current ripples. Additional features include an adjustable TEC output current limit and Integrated self-adjusted PID controller, providing optimal temperature regulation.

SF8xxx can be controlled by analogue or digital signals and switches on the board.

SF8xxx is housed in 61 × 101.6 mm package with aluminum base plate to aid thermal dissipation from laser diode. The laser diode mount is located on the board. Driver can be mounted on any thermal conductive surface enough to dissipate laser diode losses.

6. Package set

- Driver – 1 pcs
- 50 cm ribbon cable with one 8-pin connector – 1 pcs
- 50 cm ribbon cable with one 20-pin connector – 1 pcs
- Datasheet & User Manual – 1 pcs
- USB-UART converter – 1 pcs (for ZIF versions)

7. Overall dimensions and weight

LD mount and case	Overall dimensions, mm	Weight, g
10-pin for soldering	61 x 101.6 x 18.6	119
10-pin with Azimuth connectors	61 x 101.6 x 28.3	148
14-pin for soldering	61 x 101.6 x 20.1	136
14-pin with Azimuth connectors	61 x 101.6 x 28.3	142

¹ Option, USB as external adapter

8. Versions

Device	LDD MAX current, mA	LD mount	LD case
SF8025-10 / SF8025-10T	250	Soldering	10-pin Type 1 / Type 2
SF8025-ZIF10 / SF8025-ZIF10T	250	Plug-in connector	10-pin Type 1 / Type 2
SF8025-14 / SF8025-14T	250	Soldering	14-pin Type 1 / Type 2
SF8025-ZIF14 / SF8025-ZIF14 T	250	Plug-in connector	14-pin Type 1 / Type 2
SF8075-10 / SF8075-10T	750	Soldering	10-pin Type 1 / Type 2
SF8075-ZIF10 / SF8075-ZIF10T	750	Plug-in connector	10-pin Type 1 / Type 2
SF8075-14 / SF8075-14T	750	Soldering	14-pin Type 1 / Type 2
SF8075-ZIF14 / SF8075-ZIF14T	750	Plug-in connector	14-pin Type 1 / Type 2
SF8150-10 / SF8150-10T	1500	Soldering	10-pin Type 1 / Type 2
SF8150-ZIF10 / SF8150-ZIF10T	1500	Plug-in connector	10-pin Type 1 / Type 2
SF8150-14 / SF8150-14T	1500	Soldering	14-pin Type 1 / Type 2
SF8150-ZIF14 / SF8150-ZIF14T	1500	Plug-in connector	14-pin Type 1 / Type 2

9. Absolute maximum ratings

	MIN	MAX	UNIT
Vin+ to Vin-	-0.3	5.5	V
Operating temperature	-40	50	°C
Analogue control pins to GND	-0.3	5.5	V
RS-232 RXD to GND	-25	25	V
RS-232 TXD to GND	-13.2	13.2	V
UART RXD to GND	-0.3	5.5	V
UART TXD to GND	-0.3	5.5	V

Stresses beyond those listed under absolute maximum ratings may cause permanent damage to the device. These are stress ratings only, which do not imply functional operation of the device at these or any other conditions beyond those indicated under recommended operating conditions. Exposure to absolute-maximum-rated conditions for extended periods may affect device reliability.

10. Recommended operating conditions

	MIN	MAX	UNIT
Input voltage (Vin)	4.8	5.2	V
Operating temperature	-10	40	°C
Analogue control pins to GND	0	5	V
RS-232 RXD to GND	-12	12	V
RS-232 TXD to GND	-12	12	V
UART RXD to GND	0	5	V
UART TXD to GND	0	5	V

11. Power supply requirements

The driver requires a 5V DC power supply. The power supply must be able to cover the driver and TEC output power and losses. The power supply must provide 25W or more.

12. Electrical characteristics

PARAMETER	TEST CONDITIONS	MIN	TYP	MAX	UNIT
OUTPUT LDD					
Output voltage		0.5		3	V
Output current	SF8025	0		250	mA
	SF8075	0		750	
	SF8150	0		1500	
Current ripple			10	15	uA
Pulse rate	Set by RS-232 or UART	0.1		100	Hz
Pulse duration	Set by RS-232 or UART	1		5000	ms
Rise time (Soft-start time)		2.5	4	5	ms
Fall-time (Stop time)		0.7	1	1.5	ms

OUTPUT TEC					
Output voltage		0		±4	V
Output current		0		±4	A
Current ripple			2	4	mA
Temperature change range		+15		+40	°C

CONTROLS					
Enable pins low threshold				1	V
Enable pins high threshold		2.3			V
Interlock pin threshold				1	V
Interlock pin pull-up resistance			10		kΩ
LDD current set pin voltage vs. output current	SF8025		100		mA/V
	SF8075		300		
	SF8150		600		
LDD current set step	Set by RS-232 or UART		0.5		mA
LDD current set accuracy			1		%
LDD current set calibration		-5		+5	%
TEC temperature set step	Set by RS-232 or UART		0.01		°C
TEC temperature set accuracy			1		%
TEC temperature set calibration		-5		+5	%

AUX SUPPLY					
2.5V accuracy			0.2		%
2.5V output current				10	mA

INTERNAL MEASUREMENTS					
Internal measurements accuracy			2		%
LDD current monitor pin voltage vs. output current	SF8025		100		mA/V
	SF8075		300		
	SF8150		600		
External sensor temperature	NTC 10k	-10		150	°C

INPUT					
Vin quiescent current		7	10	20	mA
Operating current				7	A

13. Typical Performance Characteristics

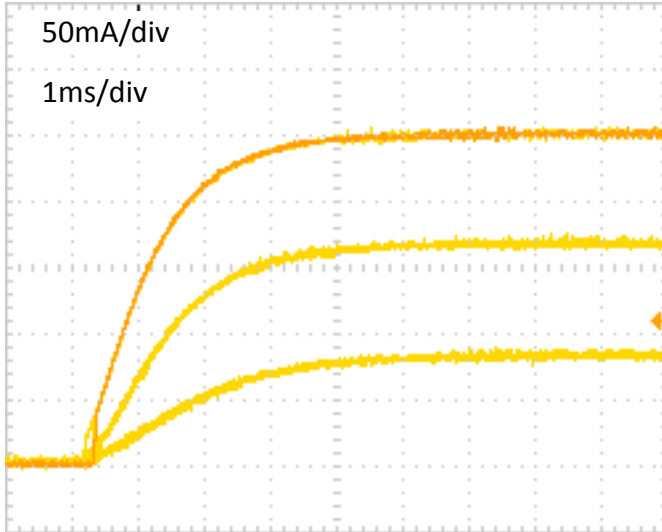

Fig. 1 – Typical start up sequence SF8025

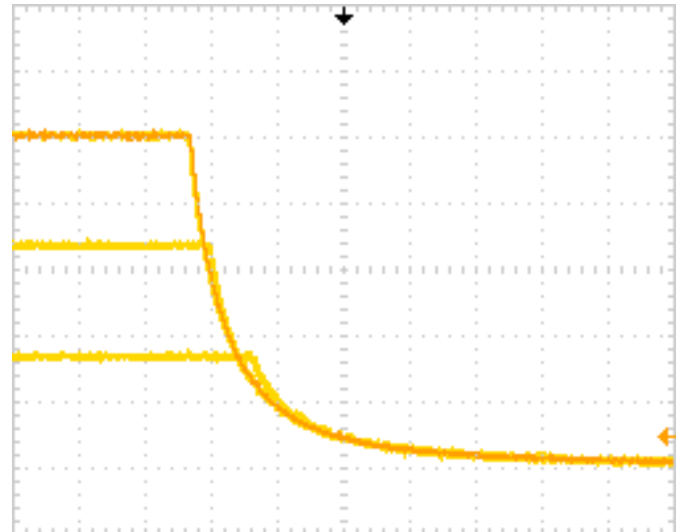

Fig. 2 – Typical stop sequence SF8025

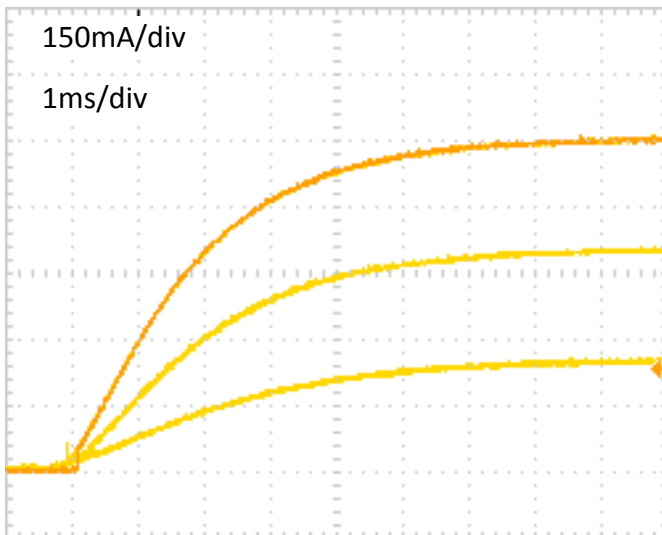

Fig. 3 – Typical start up sequence SF8075

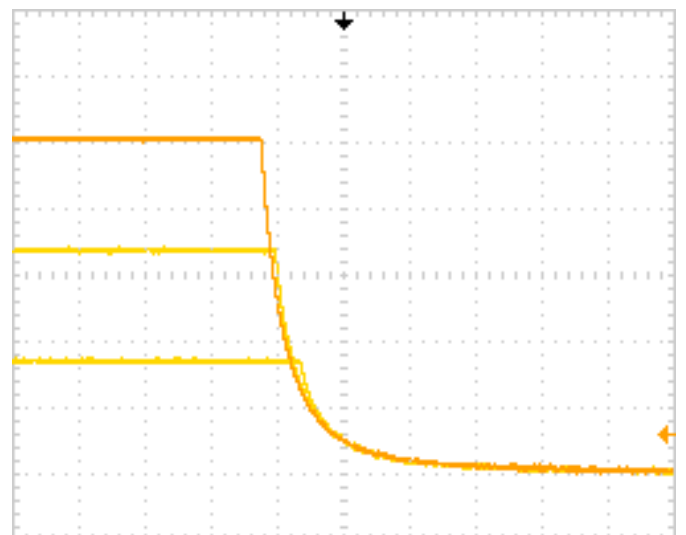

Fig. 4 – Typical stop sequence SF8075

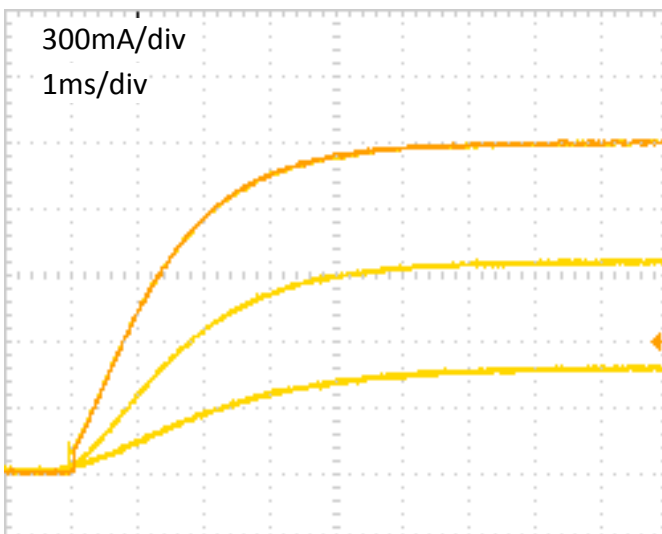

Fig. 5 – Typical start up sequence SF8150

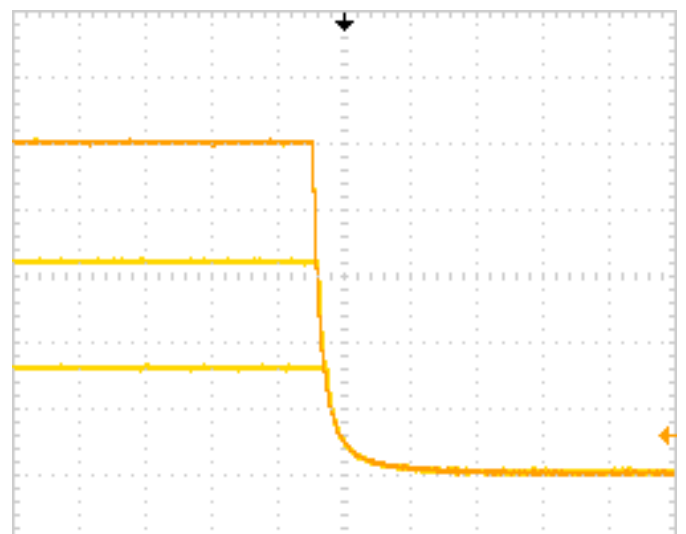
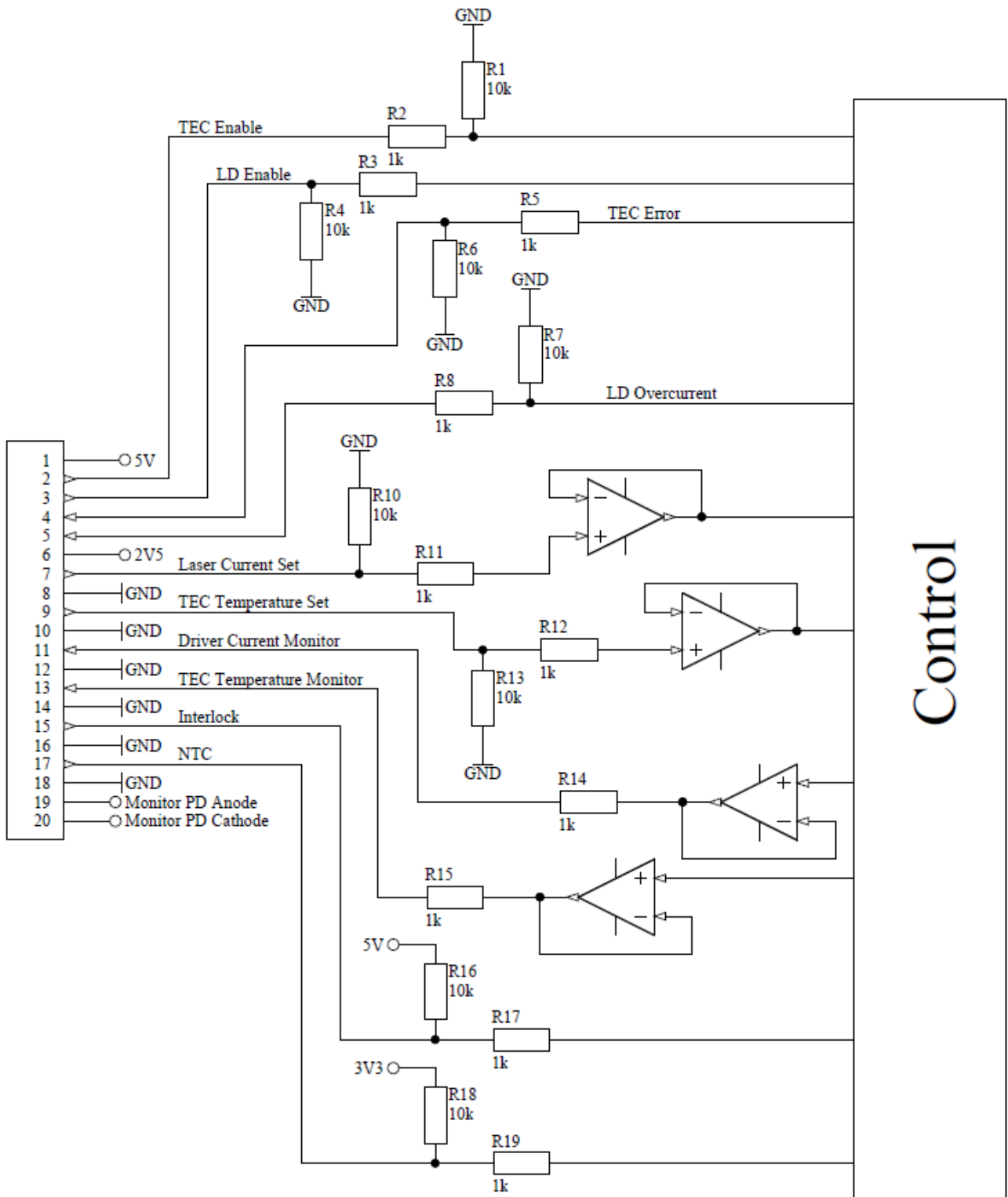

Fig. 6 – Typical stop sequence SF8150

14. Functional scheme

Analogue interface



15. Pin and terminal functions

Please, note polarity!

Never ground any lead of the output, this may cause permanent damage to the laser diode and the driver!

Never use any grounded probes (e.g. from the oscilloscope) at the output!

Control pins are not isolated!

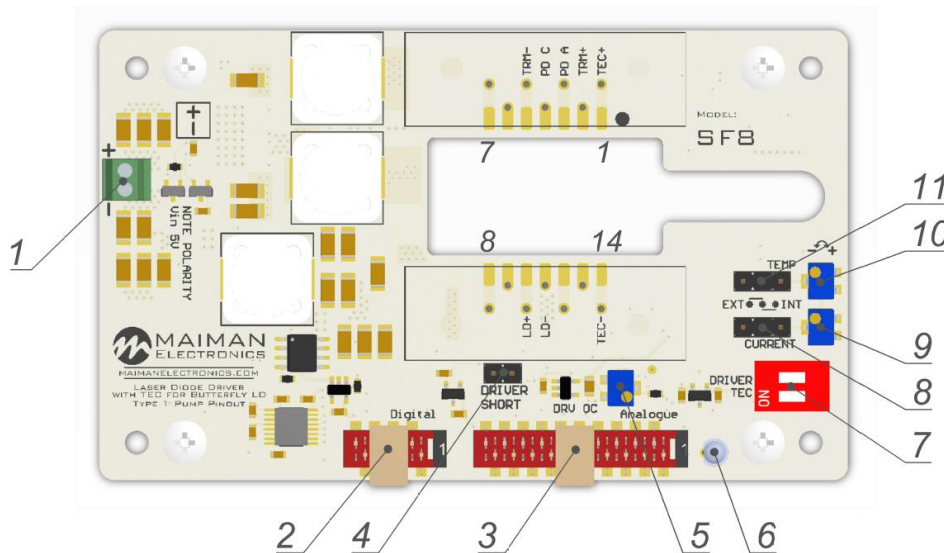

Fig. 7 – Controls (shows Type 1 layout)

No	Description
1	Terminal for connecting the power supply 5V. Maximum wire cross-section 0.75 mm ² . Please, note polarity!
2	Digital control connector
3	Analogue control connector
4	ESD protection LD short. Remove when the laser module is set up!
5	Current limit adjustment potentiometer. Turning the potentiometer clockwise increases the value, counterclockwise - reduces. Adjustment from zero to maximum occurs in 12 turns.
6	Laser diode driver overcurrent protection indicator. Lights red when the protection is activated. To reset, the device must be restarted.
7	Two-position switch. One switch enables temperature controller (TEC), another switch enables laser diode driver (DRIVER). Switches are duplicated on the analog control connector.
8	Current control selector. Close 1-2 to use analog control connector (EXT), 2-3 to use potentiometer (INT).
9	Output current of laser diode driver adjustment potentiometer. Turning the potentiometer clockwise increases the value, counterclockwise - reduces. Adjustment from zero to maximum occurs in 12 turns.
10	TEC temperature adjustment potentiometer. Turning the potentiometer clockwise increases the value, counterclockwise - reduces. Adjustment from zero to maximum occurs in 12 turns.
11	The temperature control selector. Close 1-2 to use analog control connector (EXT), 2-3 to use potentiometer (INT).

Digital control connector

Würth WR-MM 690157000872 or TE Connectivity 215083-8

Pin	Description
1	UART RXD
2	RS-232 RXD
3	UART TXD
4	RS-232 TXD
5	Connected to Vin+
6	Interlock (duplicates pin 15 of analogue control connector)
7	Crowbar status (duplicates pin 5 of analogue control connector)
8	GND (connected to Vin- terminal)

Analogue control connector

Würth WR-MM 6901 5700 20 72 or TE Connectivity 2-215083-0

PIN	I/O	Name	Description
1	O	+5V	Connected to Vin+.
2	I	TEC Enable	HIGH = operates, LOW = stop. Internally pulled down.
3	I	Laser Driver Enable	HIGH = operates, LOW = stop. Internally pulled down.
4	O	TEC Error	HIGH = fault, LOW = normal operation.
5	O	Laser Driver Overcurrent	HIGH = fault, LOW = normal operation.
6	O	+2.5V	Auxiliary +2.5V power supply. Up to 10mA output current capability.
7	I	Laser Current Set	0-2.5V = 0-MAX current at the output.
8		GND	
9	I	TEC temperature set	0V = 42°C, 2.5V = 16°C.
10		GND	
11	O	Driver Current Monitor	0-2.5V = 0-MAX current at the output.
12		GND	
13	O	TEC temperature monitor	0V = 42°C, 2.5V = 16°C.
14		GND	
15	I	Interlock	Open = locked; Low = operates. Internally pulled up.
16		GND	
17		NTC Interlock	Connect NTC thermistor 10k between this pin and GND.
18		GND	
19		Monitor PD Cathode	Connected to pin 4 (Type 1), 5 (Type 2) of Butterfly.
20		Monitor PD Anode	Connected to pin 3 (Type 1), 4 (Type 2) of Butterfly.

Laser diode pinout - Type 1

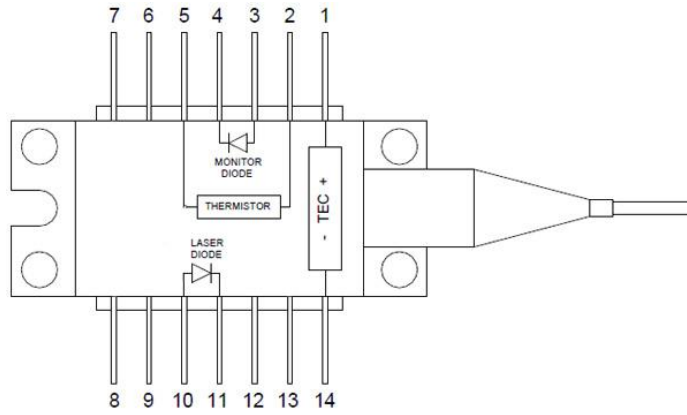

No	Description	No	Description
1	TEC Anode	14	TEC Cathode
2	Thermistor	13	n/c
3	Monitor PD Anode	12	n/c
4	Monitor PD Cathode	11	LD Cathode
5	Thermistor	10	LD Anode
6	n/c	9	n/c
7	n/c	8	n/c

Laser diode pinout - Type 2

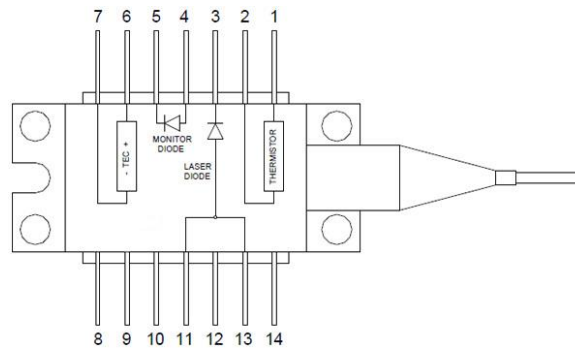

No	Description	No	Description
1	Thermistor	14	n/c
2	Thermistor	13	LD anode (+)
3	LD cathode (-)	12	n/c
4	PD anode (+)	11	LD anode (+)
5	PD cathode (-)	10	n/c
6	TEC anode (+)	9	n/c
7	TEC cathode (-)	8	n/c