

# TACHYON 1024 microCAMERA

Uncooled MWIR camera IP67-rated with industrial USB connection and 1 kHz frame rate

Optimized size and affordable cost to ensure a perfect integration in the production process: priced for cost sensitive machine vision applications!



- ▶ Miniaturized uncooled infrared MWIR camera for industrial applications
- ▶ Band of detection: MWIR (1 - 5 microns)
- ▶ Peak wavelength of detection: 3.7 microns
- ▶ FPA resolution: 32x32 (1024 pixels)
- ▶ Shutter incorporated for 1-pt offset correction
- ▶ Integration time: adjustment via software (100 – 500 us)
- ▶ Maximum frame rate: 1000 Hz (slower rates are possible)
- ▶ Global-shutter (snapshot) image acquisition
- ▶ Electrical interface: USB powered, industrial M12 mini-USB connector in the back (optional: connector in the bottom part)
- ▶ Communication interface: USB 2.0, high-speed (up to 480 Mbps)
- ▶ Data transmission: raw data, 10 bits
- ▶ Lens: f=24 mm, F#1.2, FoV 10.2°x10.2° (IP67-rated)
- ▶ Optional lens: f=48 mm, F#1.6, FoV 5.1°x5.1° (IP67-rated)
- ▶ Integrated temperature sensor
- ▶ Dimensions (in mm): 98.0 (L) x 49.5 (W) x 61.0 (H) (connector in the back)
- ▶ Weight: 250 grams
- ▶ Minimum temperature of detection: 100 °C
- ▶ IP67-rated metal housing with CS-mount optics interface
- ▶ Water-block and DLC coating for harsh environment
- ▶ Software included: NIT SOFTWARE SUITE (Acquisition and visualization SW)
- ▶ DLL for custom software development available



# TACHYON 1024 microCAMERA

## dimensions

Lens, f=24 mm, F#1.2,  
manual focus

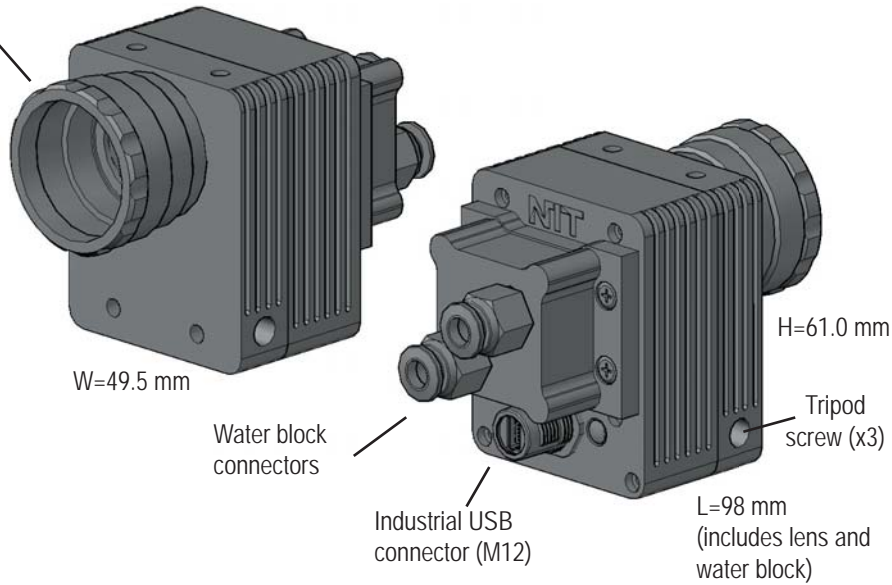

**Optional configuration: industrial USB connector (M12) in the bottom side:**

Lens, f=24 mm, F#1.2,  
manual focus

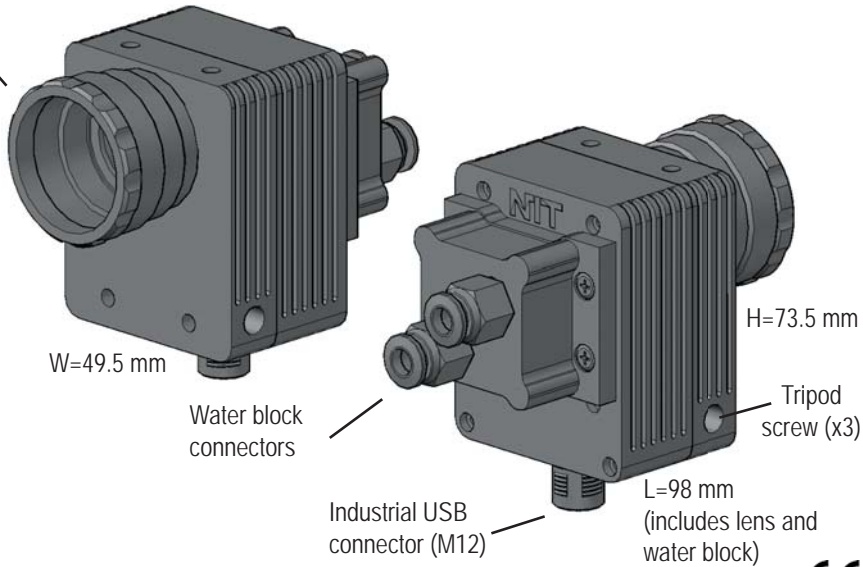

### Applications

- ▶ Industrial manufacturing process control (welding, cutting, etc.)
- ▶ Industrial automation
- ▶ Laser process monitoring
- ▶ Gas and flame detection
- ▶ Machine vision
- ▶ OEM integration

### Industries

- ▶ Automotive industry
- ▶ Home appliance manufacturing
- ▶ Metallurgy and steel industry
- ▶ Glass manufacturing
- ▶ Petrochemical industry

For more information, contact us at [sales@niteurope.com](mailto:sales@niteurope.com)



Distributor

**amSTECHNOLOGIES**  
where technologies meet solutions

[info@amstechnologies.com](mailto:info@amstechnologies.com)  
[www.amstechnologies-webshop.com](http://www.amstechnologies-webshop.com)

**Contact us**

**NIT**  
New Infrared  
Technologies