

DATASHEET AND OPERATING GUIDE

LDD P Series

Low Noise Laser Diode Drivers

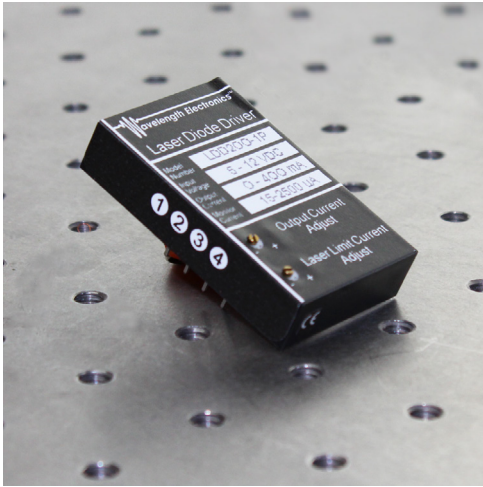

FEATURES AND BENEFITS

- Up to 400 mA current drive capacity
- +5 to +12 V single supply operation
- 12-turn trimpots control Current Setpoint and Limit Setpoint
- Operates all low power laser diodes
- Modulation up to 2MHz
- Slow start circuitry
- Buffered measurement output
- Small size
- 8-pin DIP package
- Low noise operation
- Constant Current mode operation

VERSATILITY

The LDD P Series of laser diode drivers come in two compact models to work with all laser diode/photodiode configurations. Each model is available in 200 mA and 400 mA versions to best fit your laser diode requirements.

PRECISION & HIGH PERFORMANCE

When it is essential to have high performance in your application, these low noise drivers offer excellent current stability in Constant Current mode.

Precisely control the laser diode setpoint current with the on-board Output Current Adjust trimpot or via a remote voltage to the modulation input. The modulation input's small signal 3 dB bandwidth is DC to 2 MHz.

EASY INTEGRATION

Measure laser diode current from a buffered monitor output. Optional evaluation boards are available to assist with operating any LDD P series module.

LASER SAFETY FEATURES

In order to protect laser diodes, all LDD P series drivers are equipped with current limit protection, as well as slow start circuitry. Current limit protection ensures that the diode will not be overdriven, and the slow start circuitry protects the diode from thermal shock that can damage the laser at turn on.

ORDERING INFORMATION

PART NO	DESCRIPTION
LDD200: 200 mA Laser Diode Drivers	
LDD200 1P	Type A & B lasers
LDD200 2P	Type C lasers
LDD400: 400 mA Laser Diode Drivers	
LDD400 1P	Type A & B lasers
LDD400 2P	Type C lasers
Accessories	
LDDEVALP	Evaluation Board
WCB201	3 pin laser diode connection cable (for 9 mm laser diodes)

CONTENTS

	PAGE
QUICK CONNECT GUIDE	2
PIN DESCRIPTIONS	4
ELECTRICAL SPECIFICATIONS	5
SAFETY INFORMATION	7
OPERATING INSTRUCTIONS	8
WIRING INSTRUCTIONS: LDD EVALUATION BOARD	14
ADDITIONAL TECHNICAL INFORMATION	19
TROUBLESHOOTING	25
MECHANICAL SPECIFICATIONS	26
CERTIFICATION AND WARRANTY	27

406-587-4910

www.teamWavelength.com

QUICK CONNECT GUIDE



TO ENSURE SAFE OPERATION OF THE LDD P DRIVER, IT IS IMPERATIVE THAT YOU DETERMINE THAT THE UNIT WILL BE OPERATING WITHIN THE INTERNAL HEAT DISSIPATION SAFE OPERATING AREA (SOA).

Visit the Wavelength Electronics website for the most accurate, up-to-date, and easy to use SOA calculator:

www.teamwavelength.com/support/design-tools/soa-ld-calculator/

QUICK CONNECT DIAGRAM FOR LDD 1P MODELS

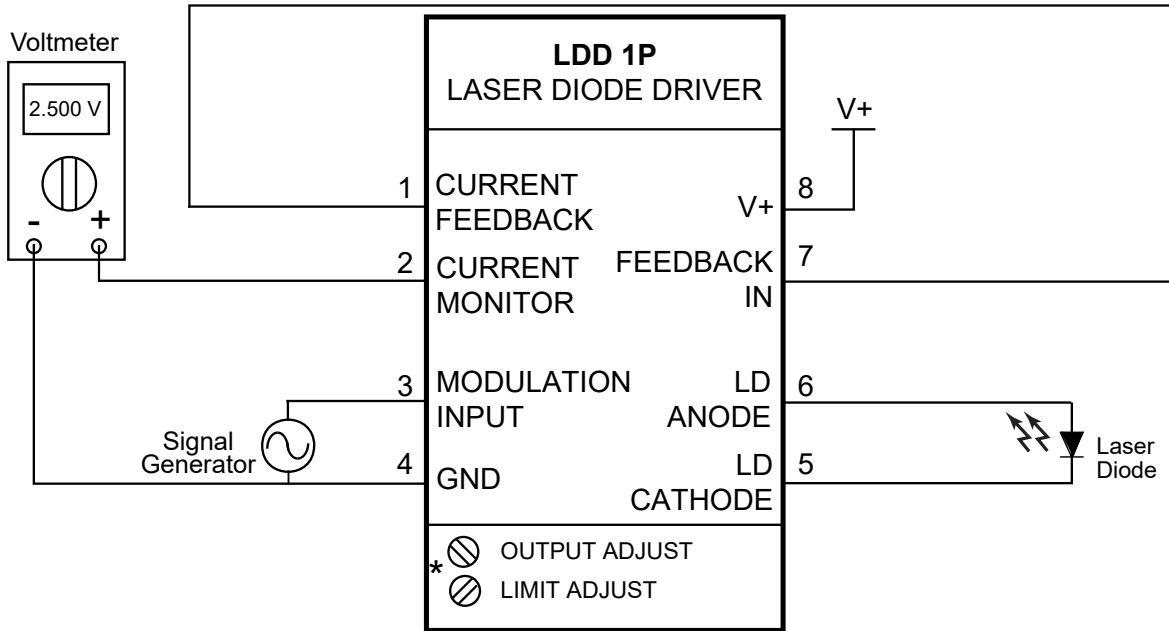

* Trimpots shown for proper orientation

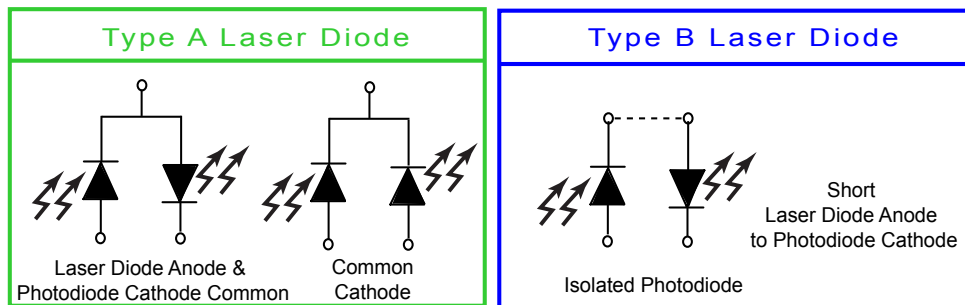

Figure 1. External connections for LDD 1P. Supports Type A and Type B laser diodes.

RECOMMENDED TEST LOAD – IP MODELS

Wavelength recommends using a test load in place of a diode laser until the user is familiar with the operation and control of the LDD P Series Laser Diode Driver.

For 1P models, the recommended test load is shown in **Figure 2**. This load is used to simulate Type A and Type B lasers.

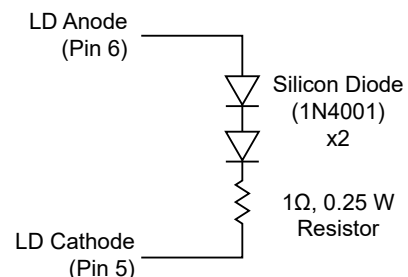
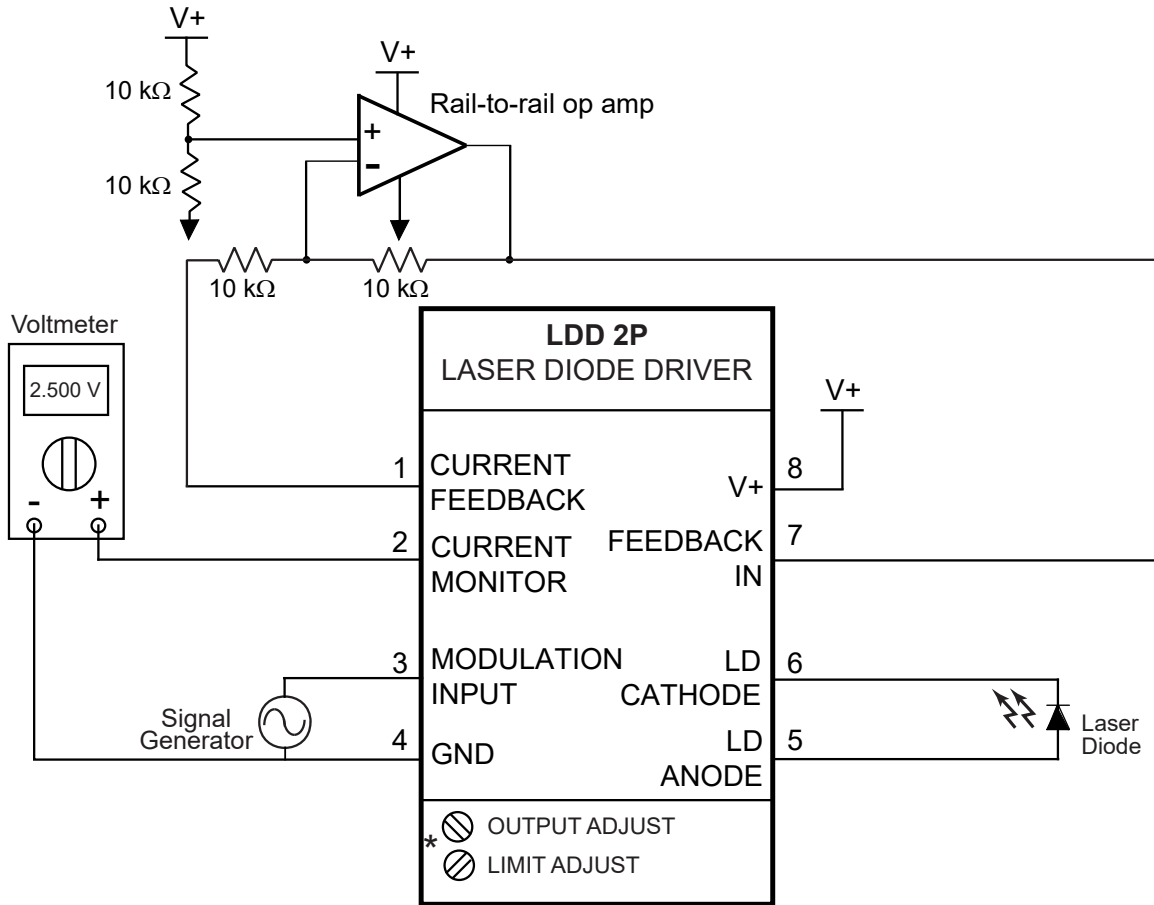

Figure 2. Recommended test load for the LDD 1P Laser Diode Driver.

QUICK CONNECT DIAGRAM FOR LDD 2P MODELS



* Trimpots shown for proper orientation

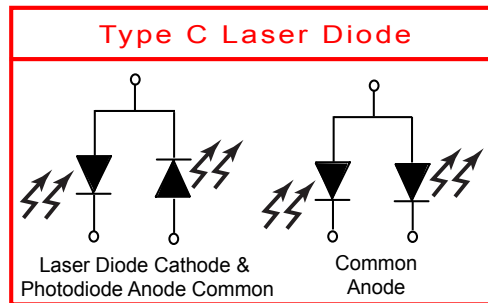

Figure 3. External connections for LDD 2P. Supports Type C laser diodes.

RECOMMENDED TEST LOAD – 2P MODELS

Wavelength recommends using a test load in place of a diode laser until the user is familiar with the operation and control of the LDD P Series Laser Diode Driver.

For 2P models, the recommended test load is shown in Figure 4. This load is used to simulate Type C lasers.

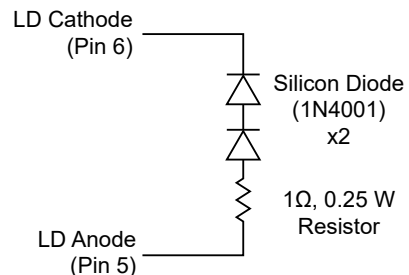

Figure 4. Recommended test load for the LDD 2P Laser Diode Driver.

PIN DESCRIPTIONS

LDD 1P

PIN #	NAME	FUNCTION
1	CURRENT FEEDBACK	Connect to Pin 7 as shown in the wiring diagram.
2	CURRENT MONITOR	Measures laser diode current. 0 to 2.5 V range.
3	MODULATION INPUT	Inverting modulation input. 0 to 5 V range. <i>Must be shorted to pin 4 (GND) to properly configure the onboard trimpots.</i>
4	GND	Power supply and monitor common connection.
5	LD CATHODE	Laser Diode Cathode.
6	LD ANODE	Laser Diode Anode. (Pin 6 internally shorted to Pin 8).
7	FEEDBACK IN	Connect to Pin 1 as shown in the wiring diagram.
8	V+	Power supply voltage connection. (Pin 6 internally shorted to pin 8). Supply range: +5 to +12 VDC.

Table 1. Pin Descriptions LDD 1P (Types A & B lasers)

LDD 2P

PIN #	NAME	FUNCTION
1	CURRENT FEEDBACK	Connect to Pin 7 as shown in the wiring diagram.
2	CURRENT MONITOR	Measures laser diode current. 0 to 2.5 V range.
3	MODULATION INPUT	Inverting modulation input. 0 to 5 V range. <i>Must be shorted to pin 4 (GND) to properly configure the onboard trimpots.</i>
4	GND	Power supply and monitor common connection. (Pin 4 internally shorted to Pin 6.)
5	LD ANODE	Laser Diode Anode.
6	LD CATHODE	Laser Diode Cathode. (Pin 6 internally shorted to Pin 4.)
7	FEEDBACK IN	Connect to Pin 1 as shown in the wiring diagram.
8	V+	Power supply voltage connection. Supply range: +5 to +12 VDC.

Table 2. Pin Descriptions LDD 2P (Type C lasers)

TRANSFER FUNCTIONS

FUNCTION	LABEL	LDD200	LDD400
Current Monitor	TF_{CM}	80 mA / V	160 mA / V
Inverting Modulation Input	TF_{MOD}	-40 mA / V	-80 mA / V

Table 3. Transfer Functions for LDD P Series Laser Diode Drivers

ELECTRICAL SPECIFICATIONS

PARAMETER	SYMBOL	LDD200	LDD400	UNIT	NOTE
ABSOLUTE MAXIMUM RATINGS					
Supply Voltage	V_{DD}	+5 to +12.5		VDC	Voltage on Pin 8
Compliance Voltage		$V_{DD} - 1.4$		VDC	
Output Current	I_{LD}	200	400	mA	See SOA Chart
Power Dissipation ^[1]	P_{MAX}	1	2	W	$T_{AMBIENT} = 25^{\circ}C$
Operating Temperature - Case ^[1]	T_{OPR}	0 to +50		$^{\circ}C$	$T_{AMBIENT} = 25^{\circ}C$
Storage Temperature	T_{STG}	-40 to +125		$^{\circ}C$	
Weight		< 1		oz	
Soldering Temperature		260 $^{\circ}C$ (10 secs)			

^[1] Maximum Operating Power derates above 25 $^{\circ}C$. The online Safe Operating Area (SOA) Chart includes this derating.

www.teamwavelength.com/support/design-tools/soa-ld-calculator/

PARAMETER	LDD200 xP	LDD400 xP	UNIT
1P	For Laser Type A or B		
2P	For Laser Type C		
CONSTANT CURRENT CONTROL			
Current Limit Range	0 - 200	0 - 400	mA
Temperature Coefficient	< 100		ppm / $^{\circ}C$
Long Term Stability, 24 hours ^[2]	< 50		ppm
Noise and Ripple (RMS) ^[3]	< 5		μA
MODULATION			
Input Impedance	1		$M\Omega$
Depth of Modulation (at 10kHz) ^[4]	90		%
Bandwidth, small signal sine wave 3dB	2		MHz
Modulation Input Damage Threshold	< -0.5 or > $V_{DD} + 0.5$		V
POWER SUPPLY			
Supply Quiescent Current	50		mA
Power Up Trip Point ^[5]	4.9		V
Power Down Trip Point ^[5]	4.2		V
MONITOR ACCURACY			
Setpoint vs. Monitor Accuracy	< 5		%
Warm-up to Rated Accuracy	1		hour

^[2] Stability tests were performed in an ambient air environment.

^[3] Laser diode forward current noise. Test was performed by measuring the AC voltage across a 50 Ω metal film resistor in series with a laser diode.

^[4] As square wave modulation frequency increases, the peak-to-peak output amplitude diminishes. For example, these graphs show the waveform shape at 10Hz and 10kHz. Depth of modulation continues to decrease after 10kHz.

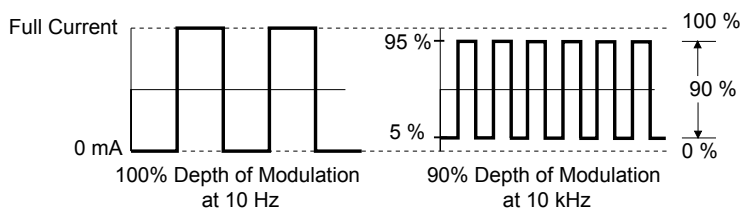

^[5] The LDD P Series has internal control circuitry which turns the output on and off depending on the voltage at pin 8. When the voltage reaches the power up trip point, the module soft starts the laser diode. When the voltage reaches the power down trip point, the module shunts current around the laser diode, powering it down in a controlled fashion.

ELECTRICAL SPECIFICATIONS – CONTINUED

SYMBOL	PARAMETER	TEST POINTS	TEST CONDITIONS*	TYPICAL
TIMING CHARACTERISTICS				
t_{DELAY}	Time delay between Power ON and Laser Diode current start	Load	LDD400 1P - 1.0Ω LDD400 2P - 1.0Ω	27.5 ms 27.5 ms
t_{RISE}	Square Wave Response, 10% to 90%	Load	LDD400 1P - 1.0Ω LDD400 2P - 1.0Ω	120 ns 220 ns
t_{FALL}	Square Wave Response, 90% to 10%	Load	LDD400 1P - 1.0Ω LDD400 2P - 1.0Ω	120 ns 220 ns
$t_{\text{SOFT START}}$	Soft start minimum (current setpoint 10% full scale)	Load	LDD400 1P - 1.0Ω LDD400 2P - 1.0Ω	140 ms 180 ms
	Soft start maximum (current setpoint 100% full scale)	Load	LDD400 1P - 1.0Ω LDD400 2P - 1.0Ω	300 ms 300 ms

*LDD200 P model results are comparable. See **Test Setup on page 21** for wiring diagram used.

SAFETY INFORMATION

SAFE OPERATING AREA – DO NOT EXCEED INTERNAL POWER DISSIPATION LIMITS

Before attempting to operate the LDD P Series driver, it is imperative that you first determine that the unit will operate within the *Safe Operating Area* (SOA). Operating outside of the SOA may damage the laser and the LDD P. Operating outside of the SOA will void the warranty.

To determine if the LDD P Series driver is suitable for your application and if it will be operating in the safe range, consult the instructions for calculating the Safe Operating Area online:

www.teamwavelength.com/support/design-tools/soa-ld-calculator/

SOA charts are included in this datasheet for quick reference (**page 24**), but we recommend you use the online tools instead.



TO ENSURE SAFE OPERATION OF THE LDD P DRIVER, IT IS IMPERATIVE THAT YOU DETERMINE IF THE UNIT IS GOING TO BE OPERATING WITHIN THE INTERNAL HEAT DISSIPATION SAFE OPERATING AREA (SOA).

If you have any questions about the Safe Operating Area calculator, call the factory for free and prompt technical assistance.

THEORY OF OPERATION

The LDD P Series drivers are controlled current sources: they deliver the current commanded by the setpoint. The current source continually monitors the actual output current, compares it to the setpoint, and adjusts the current if there is a difference between the two signals.

It may be useful to remember that you do not directly set the drive current setpoint; instead, you adjust a voltage signal that represents the output current. The voltage and output current are related by a transfer function that varies by driver model number.

The setpoint voltage is adjusted with the onboard trimpot or by an external input that **subtracts** from the onboard setpoint. The adjustable current limit is set using an onboard trimpot.

As current is driven through the load, there is a voltage drop across the load because of the impedance. As the current increases, the voltage drop may increase to the point that it reaches the Compliance Voltage limit of the current source. Once that occurs, the current source is no longer able to increase the current driven to the load even if you increase the setpoint.

The LDD P driver includes features that help protect your laser and make the driver more versatile in a wide array of applications:

- Output slow-start ramps the current to setpoint.
- Current limits prevent too much current from reaching the laser diode.

OPERATING INSTRUCTIONS

The LDD P Series Laser Diode Drivers are designed for stable, low noise operation. The power supply you select will directly affect the noise performance of the driver. We recommend using a regulated, linear power supply for optimum performance. Depending on your requirements, you may be able to use a switching power supply. Each case must be evaluated independently because a switching power supply will affect noise, transient, and stability performance.

The LDD P Series can be purchased with the LDDEVALP series evaluation kit for easy initial operation.

LASER SAFETY ISSUES

ATTENTION: If you plan to operate the LDD P with any Wavelength temperature controller, you may need to use separate power supplies. If the thermoelectric cooler or thermistor is connected to the laser diode, please contact the factory for technical assistance.

ATTENTION: Exceeding the maximum specified operating current ($I_{OP\ MAX}$) will damage your laser diode. Become familiar with the LDD P Series module operation and the exact specifications of your laser diode before attaching it to the LDD P module. Seek assistance from someone with experience working with laser diodes if you have not operated one before.

ATTENTION: The following instruments may cause momentary opens, shorts, or impedance changes that will damage a laser diode if attached to the output of a laser diode driver.

1. A **voltmeter** across the laser diode.
2. An **oscilloscope** across the laser diode.
3. A **current meter** in series with the laser diode.

All measurements made with these instruments on the output should be made with a simulated load attached and not a laser diode.

OPTIONAL: If laser diode and photodiode are isolated (Type B Laser Diode), short the laser diode anode to the photodiode cathode. The LDD P Series laser diode drivers require the photodiode be connected to the laser diode.

NECESSARY EQUIPMENT

The following equipment is the minimum necessary to configure the LDD P for basic operation:

- LDD P controller
- Digital voltmeter, 4-½ digit resolution recommended
- Test load for configuring the driver
- Laser diode, mount, and optional temperature control system
- Connecting wires
- Power supply
- LDDEVALP and soldering iron (optional)

SAFE OPERATING AREA AND THERMAL DESIGN CONSIDERATIONS

SOA charts are included in this datasheet for quick reference, but we recommend you use the online tools instead.

www.teamwavelength.com/support/design-tools/soa-ld-calculator/



IT IS IMPERATIVE THAT YOU VERIFY THE UNIT WILL OPERATE WITHIN THE INTERNAL HEAT DISSIPATION SAFE OPERATING AREA (SOA).

OPERATING THE DRIVER OUTSIDE THE SOA MAY DAMAGE OR DESTROY THE DRIVER AND/OR LASER.

PREVENT DAMAGE FROM ELECTROSTATIC DISCHARGE

Before proceeding, it is critical that you take precautions to prevent electrostatic discharge (ESD) damage to the driver and your laser. ESD damage can result from improper handling of sensitive electronics, and is easily preventable with simple precautions.

For more information regarding ESD, see Application Note [AN-LDTC06: Basics: Electrostatic Discharge \(ESD\)](#).

We recommend that you always observe ESD precautions when handling the LDD P driver and your laser diode.

GROUNDING

Some laser diode packages short either the laser diode anode or cathode to the case, which may connect the laser electrically to earth ground. Review the internal connections of the LDD P to make sure ground loops are not inadvertently created by this situation. Special attention to the details of grounding will ensure safe operation.

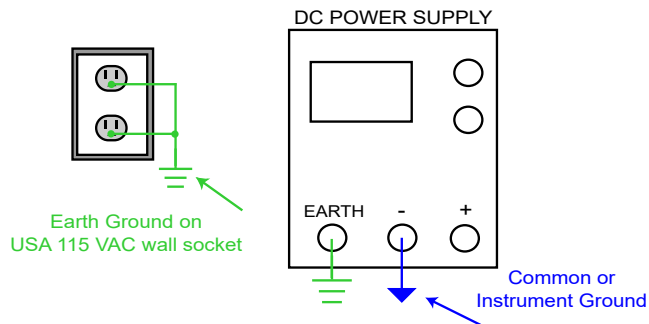

Unless Earth and Instrument Ground are connected via the power supply, Instrument Ground is floating with respect to Earth Ground

WIRING THE LDD P SERIES FOR CONSTANT CURRENT OPERATION

Figure 5 through Figure 7 give the wiring diagrams to operate the different LDD P models in Constant Current mode.

To simplify wiring, use evaluation board LDDEVALP. Setup diagrams are found on page 14.

RECOMMENDED TEST LOADS

Figure 5 illustrates how to create a constant current simulated load for the LDD P Series laser diode drivers. The simulated load allows the configuration of the LDD P without initially connecting the laser diode. Once the laser diode driver is adjusted to the correct output current and laser diode limit current, power it down before connecting a laser diode.

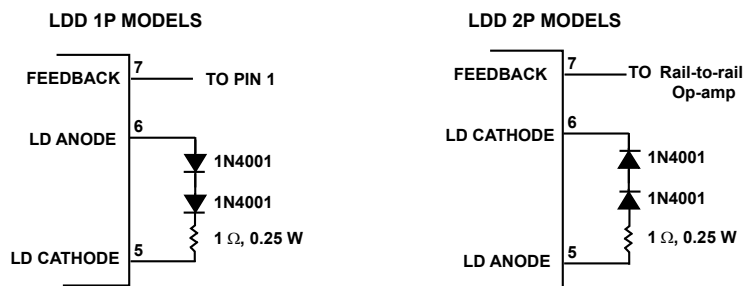

Figure 5. The test loads shown above simulate a constant current load for the LDD P Series Laser Diode Drivers.

WIRING LDD 1P MODELS

Figure 6 below shows the wiring diagram for LDD200 1P and LDD400 1P models. Additional discussion of resistor R_D can be found on page 16 for factory recommendation, and on page 19 for custom value recommendation.

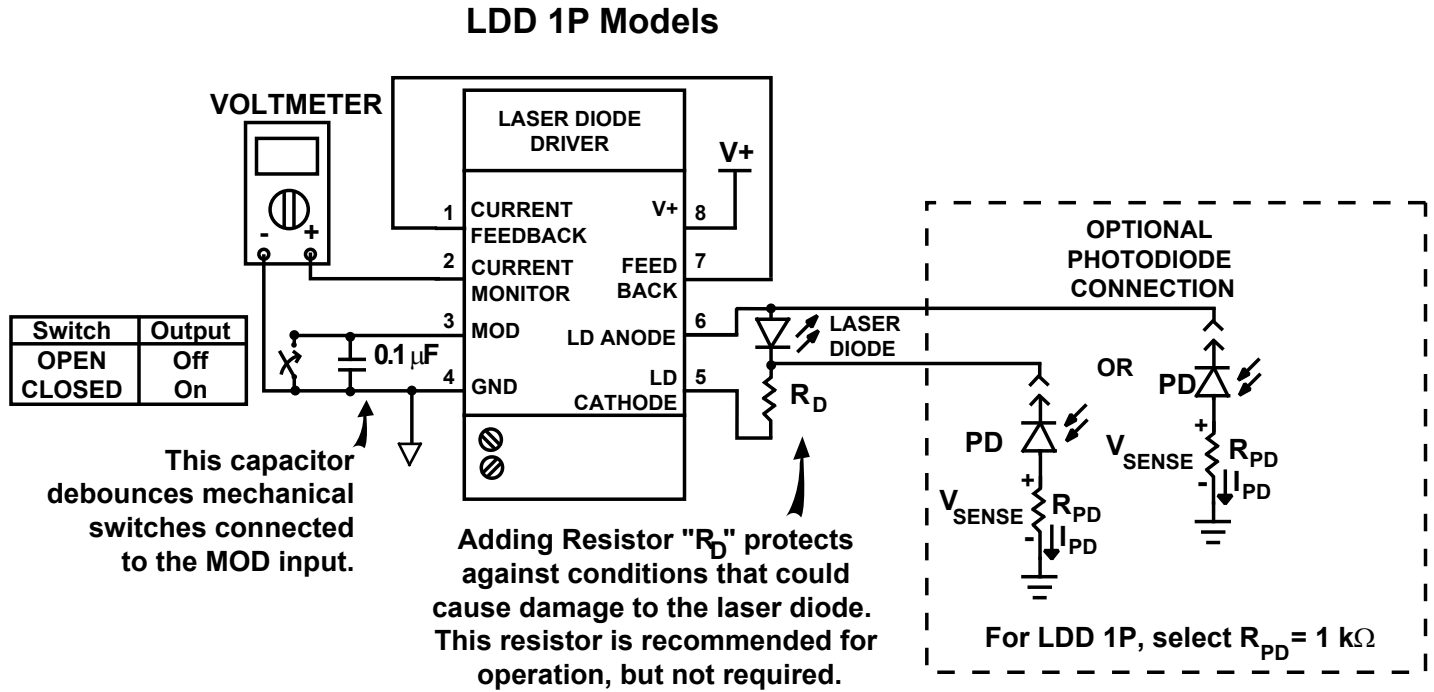

Figure 6. Wiring diagram for LDD 1P models. For use with Type A and Type B diode lasers.

WIRING LDD 2P MODELS

Figure 7 below shows the wiring diagram for LDD200 2P and LDD400 2P models. Additional discussion of resistor R_D can be found on page 16 for factory recommendation, and on page 19 for custom value recommendation.

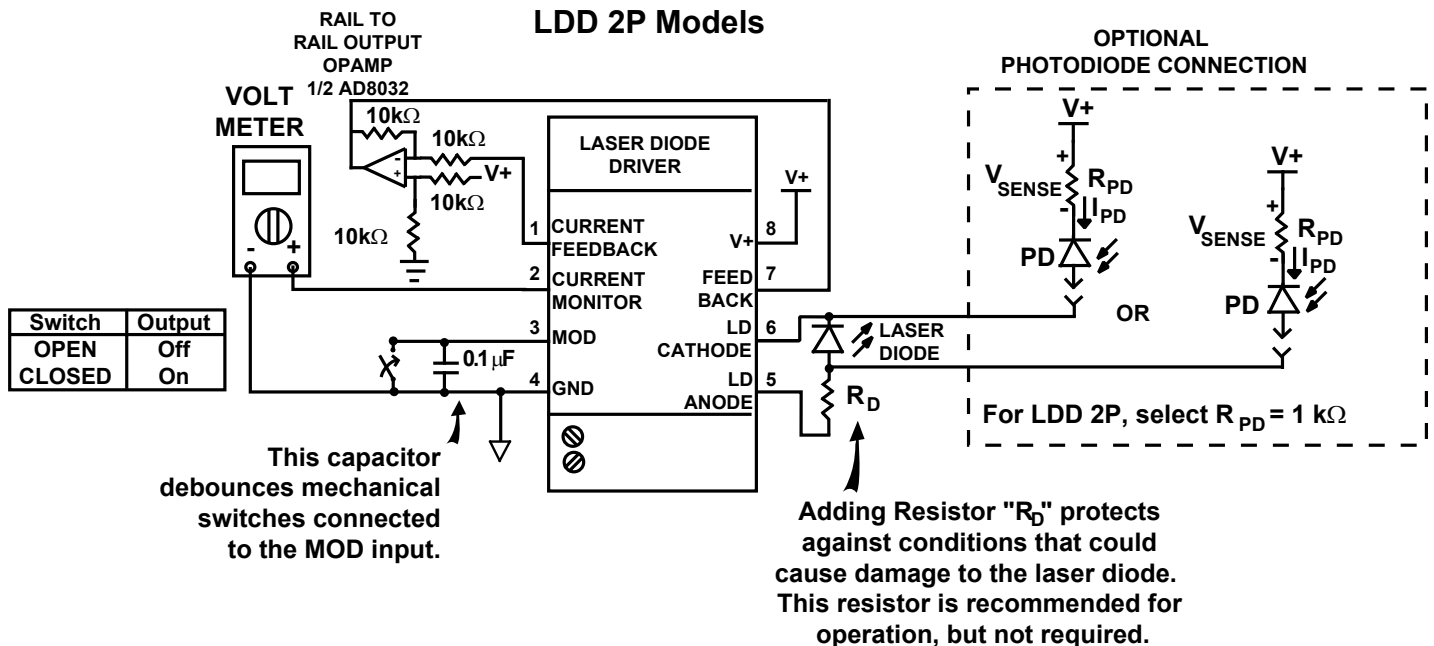

Figure 7. Wiring diagram for LDD 2P models. For use with Type C diode lasers.

CONSTANT CURRENT MODE OPERATION



DO NOT POWER ON THE LDD P SERIES LASER DIODE DRIVER UNTIL ALL WIRE CONNECTIONS ARE COMPLETELY ATTACHED AND THE OUTPUT CURRENT ADJUST AND LIMIT CURRENT ADJUST TRIMPOTS HAVE BEEN CORRECTLY CONFIGURED.



BEFORE CONNECTING A POWER SUPPLY TO THE LDD P SERIES LASER DIODE DRIVER, MEASURE THE SUPPLY'S OUTPUT VOLTAGE AND ENSURE A READING BETWEEN +5 AND +12 VOLTS. TURN OFF THE POWER SUPPLY BEFORE CONNECTING THE LDD P.

ADJUSTING ON-BOARD TRIMPOTS

The two trimpots on the LDD P Series are:
Output Current Adjust and Laser Limit Current Adjust

Maximize the Output Current Adjust trimpot. Turn the trimpot fully clockwise, at least 12 complete turns.

Zero the Laser Limit Current Adjust trimpot. Turn the trimpot fully counter-clockwise, at least 12 complete turns.

Both adjustments are shown below in **Figure 8**.

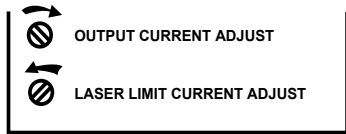

Figure 8. Adjusting the two on-board trimpots.

MEASURE CURRENT MONITOR OUTPUT

Pin 2 (Current Monitor) is used to monitor the current output to the laser diode. The voltage measured can be converted to current using the transfer function in **Table 3**.

To measure, attach the positive input of a voltmeter to the current monitor output (pin 2) and the negative input of the voltmeter to ground (pin 4), as shown in **Figure 9**.

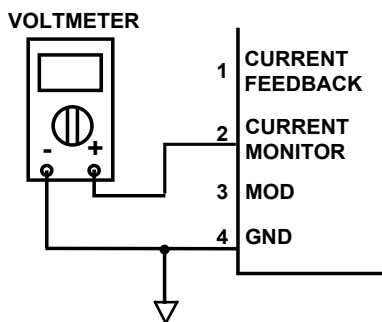

Figure 9. Connect the voltmeter as shown to measure the power monitor output.

TURN ON VOLTAGE SOURCE

Apply power to the LDD P only after all connections have been thoroughly reviewed. Note the modulation input, pin 3, must be connected to ground, pin 4, to properly configure the onboard limit current and laser diode current trimpots.

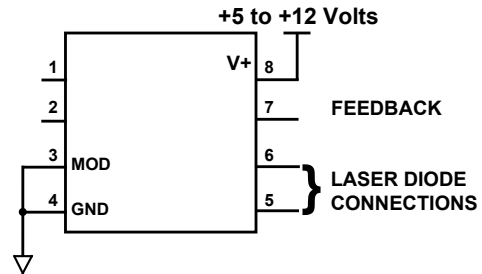

Figure 10. Connect pins 3 and 4 (modulation and ground) to properly configure the LDD P.

ADJUST LASER DIODE LIMIT CURRENT

Calculate the current monitor voltage that corresponds to the proper limit current (I_{LIMIT}) setting. Do not exceed the maximum operating current of the laser diode.

Ensure that I_{LIMIT} has units of mA, and use **Equation 1** to calculate what limit voltage (V_{LIMIT}) should be measured at pin 2.

$$\text{Equation 1. } V_{PIN 2} = V_{LIMIT} = I_{LIMIT} / (TF_{CM})$$

where TF_{CM} is the Current Monitor transfer function (model-dependent) found in **Table 3 on page 4**.

Then, SLOWLY adjust the Limit Current Adjust trimpot clockwise until the voltmeter attached to the current monitor (pin 2) reads V_{LIMIT} .

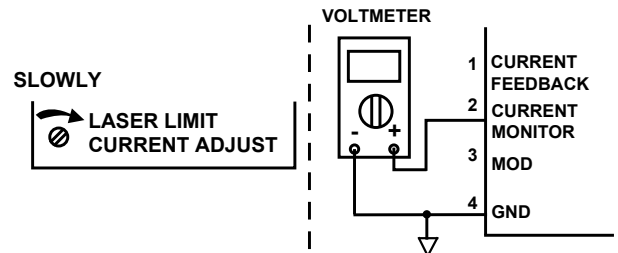

Figure 11. Set the Limit Current Adjust trimpot to the limit voltage.

ADJUST LASER DIODE CURRENT

Before beginning, rotate the Output Current Adjust trimpot fully counter-clockwise, at least 12 turns to zero the setpoint.

Using the desired operating current, I_{OP} , calculate the corresponding monitor voltage (V_{OP}) using **Equation 2**.

Equation 2. $V_{PIN2} = V_{OP} = I_{OP} / (TF_{CM})$

Where, again, the current must be given in mA, and TF_{CM} can be found in **Table 3 on page 4**.

Then, SLOWLY adjust the Output Current Adjust trimpot clockwise until the voltmeter attached to the current monitor (pin 2) reads V_{OP}

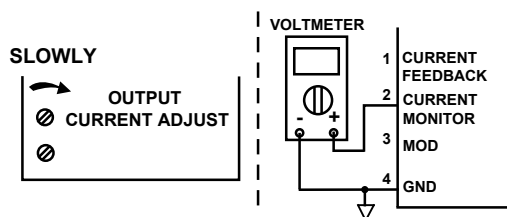

Figure 12. Set the Output Current Adjust trimpot to the operating voltage.

DISABLE LASER DIODE CURRENT

To disable current, let pin 3 float or connect it to V+. **Figure 13** shows an example of how to wire a switch to the LDD P to enable/disable current.



A RESIDUAL CURRENT IS PRESENT IN THE LASER DIODE WHEN DISABLED. DO NOT DISCONNECT THE LASER DIODE UNLESS POWER IS REMOVED FROM V+ AND GROUND.

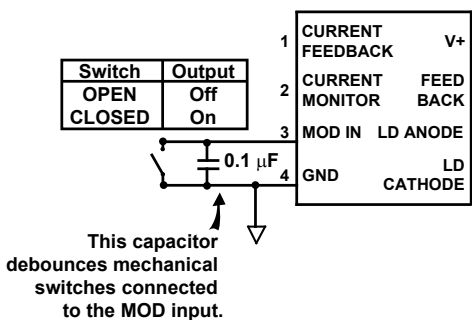

Figure 13. Disable current by opening the switch (as shown) or floating pin 3.

VERIFY PHOTODIODE CURRENT LEVEL (OPTIONAL)

If you wired an external photodiode (see **Figure 6 & Figure 7**), attach the leads of a voltmeter across the external resistor as shown in **Figure 14**.

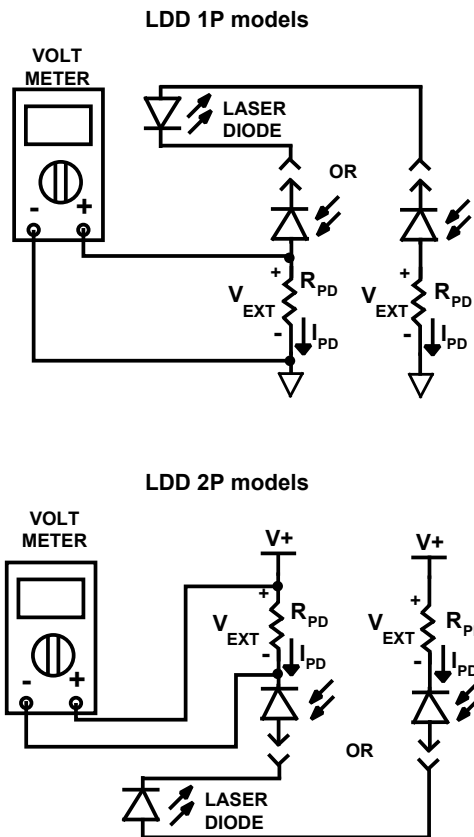

Figure 14. Connect the voltmeter across the external resistor.

To find the actual photodiode current, use **Equation 3** below. This value may vary depending on the temperature of the laser diode. A laser diode with a temperature above 25°C will produce less photodiode current than one at or below 25°C.

Equation 3. $I_{PD} = V_{EXT} / 1k\Omega$

ADJUST LASER DIODE CURRENT VIA MODULATION (OPTIONAL)

There are two ways to utilize the Modulation Input to adjust the laser diode current remotely:

- Connect an external trimpot or potentiometer to pin 3. See upper half of **Figure 15**.
- Connect a signal generator to pin 3. See lower half of **Figure 15**.

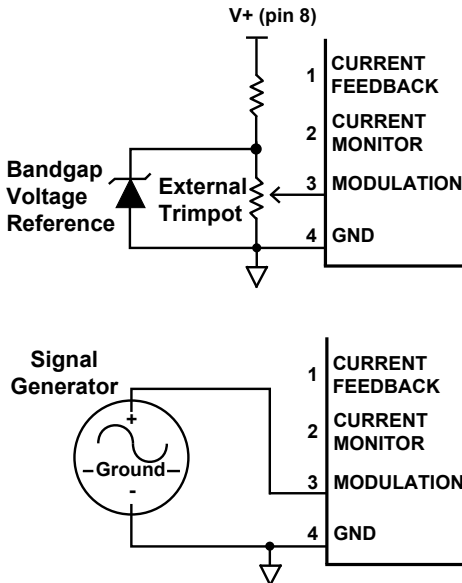

Figure 15. Two separate ways to control the laser diode current remotely.

Upper: External Trimpot connected to pin 3.

Lower: Signal Generator connected to pin 3.

The modulation input adjusts the laser diode current by reducing the laser diode current from the setting determined by the Output Current Adjust trimpot proportional to the voltage applied to pin 3.

The modulation current (I_{MOD}) is given by **Equation 4**.

$$\text{Equation 4. } I_{MOD} = I_{OP} + V_{PIN3} (TF_{MOD})$$

where TF_{MOD} is the laser diode transfer function found in **Table 3**. Recall that TF_{MOD} is negative.

CAUTION: The modulation input voltage must always be maintained within the power supply voltage range between pin 8 and pin 4. A voltage on the modulation input below ground may produce excessive laser diode currents.

WIRING INSTRUCTIONS: LDD EVALUATION BOARD

The LDD P is designed to be soldered to a circuit board. The LDDEVALP evaluation board integrates with any LDD P laser diode driver to speed up prototyping.

Figure 16 shows a top view of all of the components on the LDDEVALP. The remaining pages of this section elaborate on each component labeled. **Table 4** gives a summary of the individual components, along with the page the detailed component description can be found.

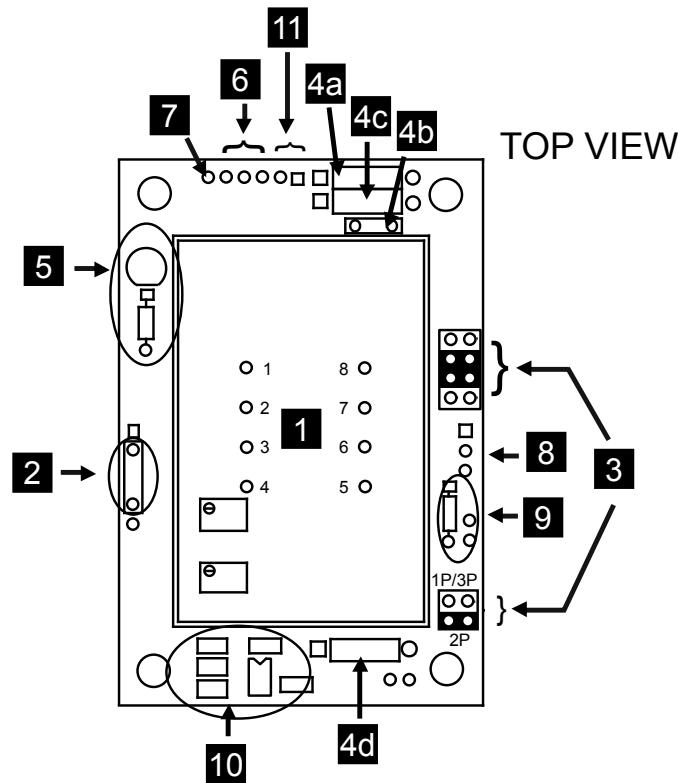

Figure 16. LDDEVALP Component Diagram.
For more detail, refer to sections on following pages.

NUMBER	COMPONENT	FUNCTION	PAGE
1	LDD Module	Laser Diode Driver Component location	page 16
2	Enable/Disable wire pads	Enable/Disable laser current	page 16
3	Jumpers	Select LDD P model	page 16
4a	Decoupling Resistor	Decouple power supply	page 16
4b	Decoupling Capacitor	Decouple power supply	page 16
4c	Transzorb	Over-voltage protection	page 16
4d	Dominant Impedance	Laser diode over-current and transient protection	page 16
5	LED and bias resistor	Power ON indicator	page 17
6	Measurement wire pads	Measure laser diode current	page 17
7	MOD INPUT wire pads	Connections to optional signal generator	page 17
8	Laser diode wire pads	Solder laser diode cable to these pads	page 17
9	External photodiode wire pads	Monitor photodiode current while in constant current mode	page 17
10	Op-amp, four resistors, one capacitor	For operating LDD 2P in constant current mode	page 18
11	Power supply wire pads	Connections to power supply	page 18

Table 4. Typical Component Functions

LDDEVALP SCHEMATIC

The schematic for the LDDEVALP is shown below in **Figure 17**.

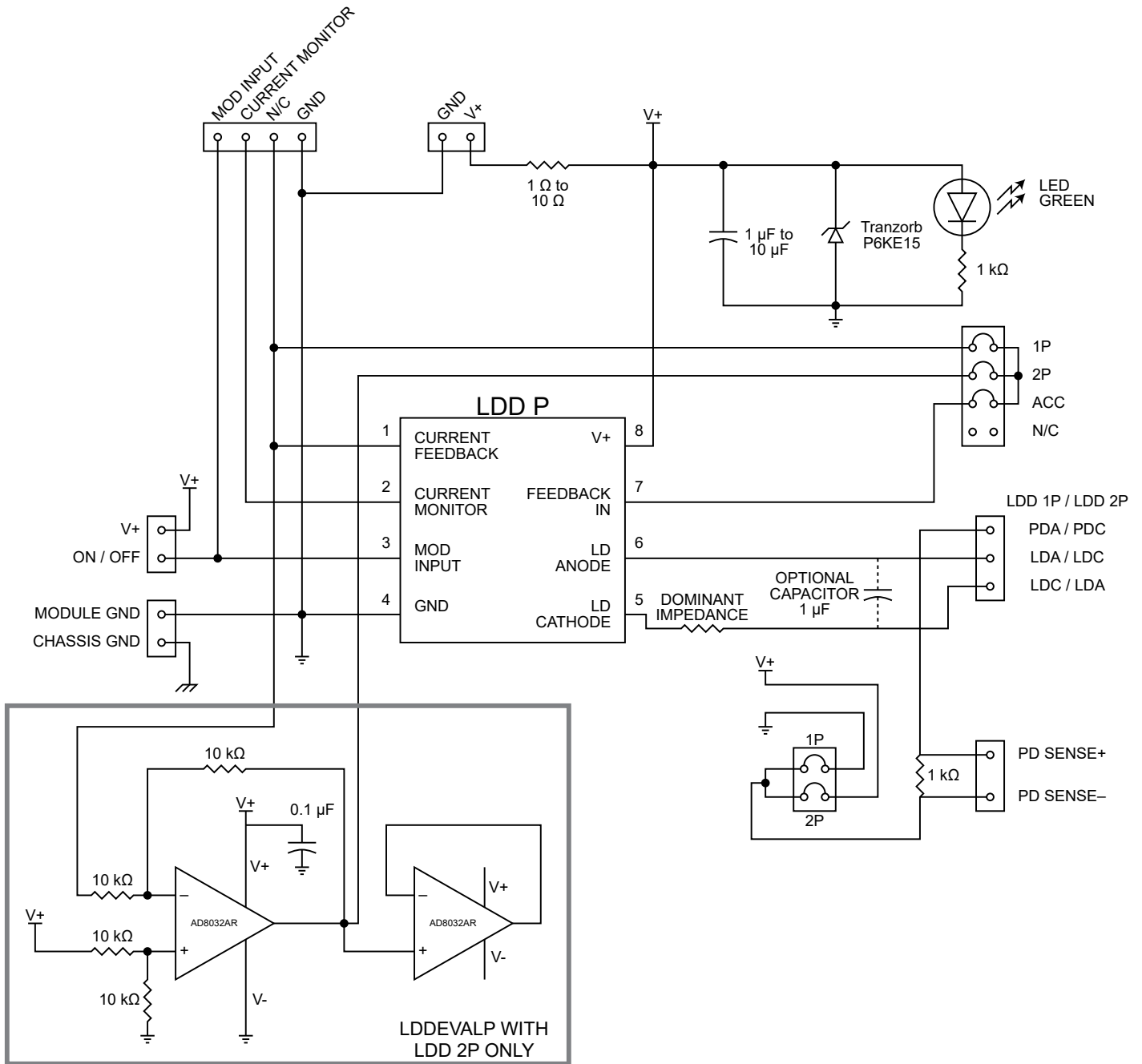

Figure 17. LDDEVALP Schematic

COMPONENT DETAILS

COMPONENT 1: SOLDER LDD P TO EVALUATION BOARD

The silkscreen on the top of the board shows the orientation of the two trimpots when the LDD P module is properly positioned. Solder the LDD P to the circuit board. Do not exceed solder tip temperature of 260°C, or apply heat to any lead for more than 10 seconds.

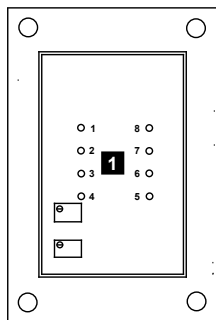

Figure 18. Ensure that the LDD P is properly oriented prior to soldering.

COMPONENT 2: ENABLE LASER DIODE CURRENT

To enable laser diode current, choose one of the two options below:

1. Solder a jumper between the two round solder pads.
2. Use a switch to enable and disable the laser diode current. Connect it across the round solder pads. Place a capacitor across the switch to debounce the connection.

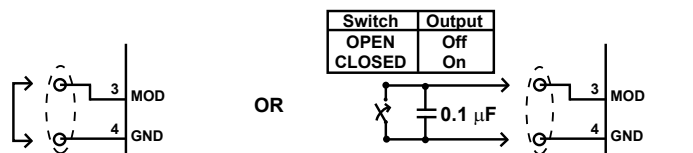

Figure 19. Enable laser diode current by connecting the solder pads as shown.

COMPONENT 3: CONFIGURE JUMPERS

The top set of jumpers configures operation in Constant Laser Diode Current Mode based on the LDD P model.

A second set of jumpers, lower on the LDDEVALP, is used to monitor external photodiode current in Constant Current mode (see inside the dashed box in Figure 20).

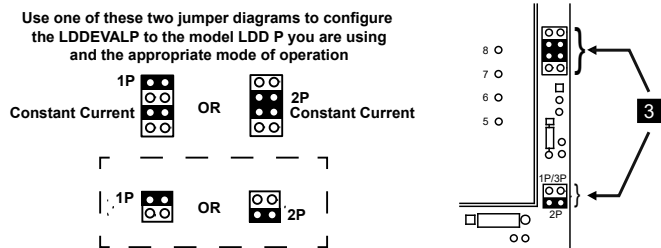

Figure 20. Properly configure the jumpers for the LDD P model being used.

COMPONENT 4: SAFETY COMPONENTS

Component 4a: Power Supply Decoupling Resistor

This optional* series resistor forms a low pass single pole filter with the capacitance seen from pin 8 to ground. This component is not recommended for V+ operation below 6 V. A 1 Ω resistor is installed on the LDDEVALP.

* If the decoupling resistor is removed, a jumper between the two solder pads must be installed.

Component 4b: Power Supply Decoupling Capacitor

To shunt regulate the power supply around the LDD P laser diode driver, a 10 μF capacitor is installed on the LDDEVALP.

To use a different capacitor, remove the 10 μF capacitor, and install the desired capacitor. Note the polarity marked on the silkscreen

Component 4c: Over-voltage protection – Transzorb

This Zener diode limits the voltage differential across the LDD P. A Motorola P6KE15A is installed on the LDDEVALP.

Component 4d: Dominant Impedance

This optional** resistor limits the voltage that can develop across the laser diode in the case of a power supply transient or if the connections to the laser diode are broken and reconnected. A 1 Ω, 2 W resistor is installed on the LDDEVALP.

For instructions to change the value of the dominant impedance resistor, see “Custom Dominant Impedance Values” on page 19.

** If the dominant impedance resistor is removed, a jumper between the two solder pads must be installed.

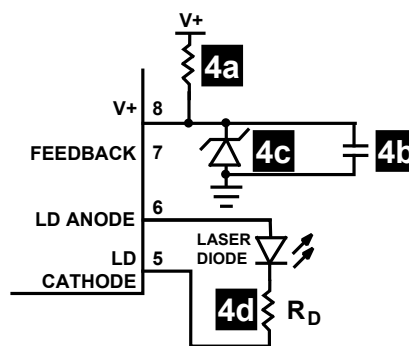

Figure 21. Schematic of safety components. Factory values:

- Resistor 4a = 1Ω
- Capacitor 4b = 10μF
- Zener Diode 4c = Motorola P6KE15A
- Resistor 4d = 1Ω, 2W

COMPONENT 5: POWER ON INDICATOR LED

When power is applied to the LDD P evaluation board, this LED will light.

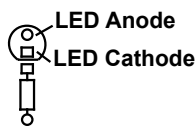

Figure 22. Component locator with LED.

COMPONENT 6: MONITOR LASER DIODE CURRENT

Pin 2 (Current Monitor) is used to monitor laser diode current during setup and operation. This pin is brought out to a solder pad on the edge of the evaluation board.

Attach the positive input of a voltmeter to the current monitor solder pad and the negative input of the voltmeter to ground as seen in Figure 23.

NOTE: For noise reduction, use the Monitor Ground solder pad, not the Power Supply ground solder pad.

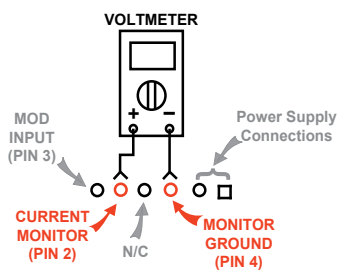

Figure 23. Connect the voltmeter as shown to monitor laser diode parameters.

COMPONENT 7: CONNECT SIGNAL GENERATOR (OPTIONAL)

Pin 3 is the modulation input. This pin is brought out to a solder pad on the edge of the board.

Attach the positive input of a signal generator to the MOD INPUT solder pad and the negative input of the signal generator to the Monitor Ground as shown in Figure 24.

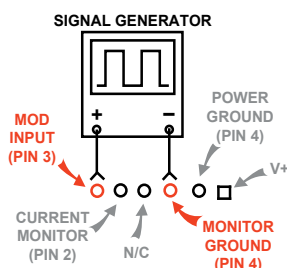

Figure 24. Connect a signal generator to MOD INPUT.

COMPONENT 8: CONNECT LASER DIODE TO EVALUATION BOARD

The three solder pads (shown in Figure 25) that make up Component 8 are labeled 5, 6, and 7. Pads 5 and 6 correspond to pins 5 and 6 of the LDD P module. Pad 7 is used for optional monitoring of the photodiode current. Refer to page 10 for Wiring Instructions for Constant Current mode.

PHOTODIODE CONNECTION 7 □



Figure 25. Use pins 5 and 6 to connect the Laser Diode.

COMPONENT 9: MONITOR PHOTODIODE CURRENT (OPTIONAL)

For LDD 1P laser diode drivers, connect the anode of the photodiode to pad 7 on the LDDEVALP. Connect the photodiode cathode to the laser diode (in most laser diodes, this connection is made inside the laser diode case). See the upper half of Figure 26 for an illustration.

For LDD 2P laser diode drivers, connect the cathode of the photodiode to pad 7 on the LDDEVALP. The photodiode anode should already be connected to the laser diode inside the laser diode case. See the lower half of Figure 26 for an illustration.

Next, install the sense resistor (included but not installed) across the two wire pads indicated in the diagram. Use a 1 kΩ resistor for both the LDD 1P and LDD 2P models.

During operation, monitor the voltage across the PD SENSE solder pads with a voltmeter.

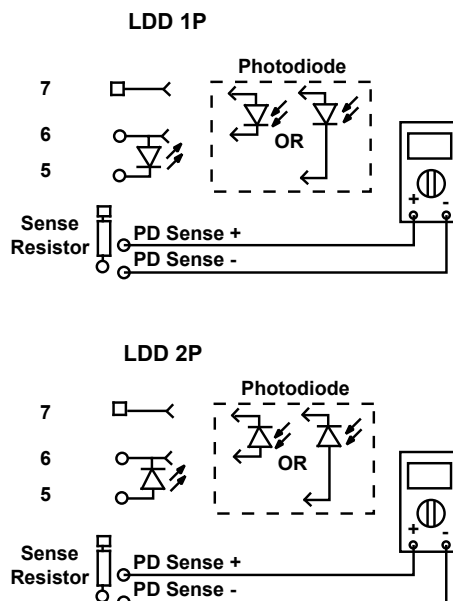

Figure 26. Wire the photodiode as shown, depending on LDD P model, to monitor photodiode current.

COMPONENT 10: LDD 2P IN CONSTANT CURRENT OPERATION

To operate an LDD 2P in constant laser diode current mode, an external op-amp and components are required (see **Figure 27**). These are installed on the LDDEVALP.

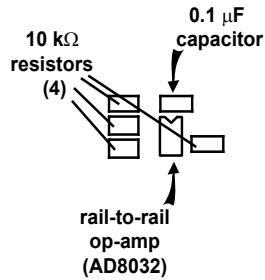

Figure 27. Required components for LDD 2P to operate in Constant Current mode.

COMPONENT 11: CONNECT POWER SUPPLY

Connect V+ and Ground to the solder pads indicated in **Figure 28** below.

NOTE: To minimize noise, use the Power Ground solder pad, not the Monitor Ground solder pad.

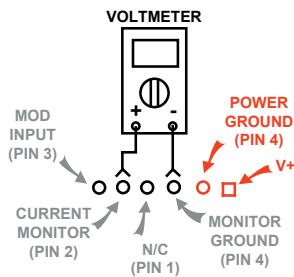

Figure 28. Connect the power supply as shown.

ADDITIONAL TECHNICAL INFORMATION

This section includes useful technical information on these topics:

- Custom Dominant Impedance Values
- External Trimpot Circuit
- Change the Modulation Transfer Function
- Laser Diode Protection for Long Cables
- Filter the LDD P Output
- Convert Current Monitor to 1mV/mA
- Using a TTL Signal at MOD INPUT
- Performance Graphs
- Safe Operating Area Calculation

CUSTOM DOMINANT IMPEDANCE VALUES

If using the LDDEVALP, the factory installed dominant impedance resistor must first be removed. Determine the appropriate value of R_D , then install the desired resistor.

Select either a metal film power resistor or a non-inductive wire wound resistor. Carbon based resistors add a significant amount of noise and inductive wire wound resistors can damage the laser diode. Use **Equation 5** below to determine custom R_D values,

$$\text{Equation 5. } R_D = [(V_{\text{SUPPLY}} - V_{\text{LD}} - 0.2) / I_{\text{LIMIT}}] - (R_{4a} + 6.2n) ,$$

where V_{SUPPLY} is the power supply voltage, V_{LD} is the forward voltage of the laser diode, I_{LIMIT} is the user-set current limit, R_{4a} is the power supply decoupling resistor described above (default value on the LDDEVALP of 1 Ω), and n is a constant that depends on LDD P model. **Table 5** below defines n for the different models of the LDD P.

MODEL	n
LDD200	1
LDD400	0.5

Table 5. Determine the appropriate constant to use for custom R_D values.

EXTERNAL TRIMPOT CIRCUIT

To set up an external trimpot circuit, see the wiring diagram in **Figure 29** below.

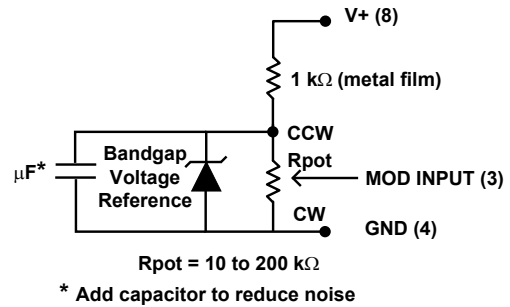
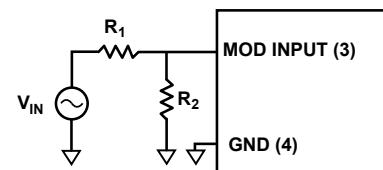

Figure 29. Wire an external trimpot circuit as shown.

CHANGE THE MODULATION TRANSFER FUNCTION

Figure 30 below shows how to change the modulation transfer function.



Keep R_1 and R_2 below 100 k Ω for maximum accuracy.

$$\text{New Transfer Function} = \left(\frac{R_2}{R_2 + R_1} \right) \text{ Original Transfer Function}$$

Example:
(for LDD200-1P, Constant Current Mode) $R_1 = 1 \text{ k}\Omega$
 $R_2 = 9 \text{ k}\Omega$

$$\text{New Transfer Function} = \left(\frac{9}{1 + 9} \right) (-40 \text{ mA} / \text{V}) = -36 \text{ mA} / \text{V}$$

Figure 30. Changing the modulation transfer function.

LASER DIODE PROTECTION FOR LONG CABLES

With a cable longer than two feet (61 cm), add a Schottky diode across the laser diode as shown in **Figure 31**.

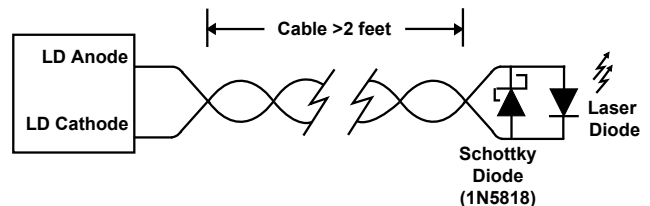

Figure 31. Schottky Diodes will protect the laser diode when using long cables.

FILTER THE LDD P OUTPUT

If you are not modulating the laser diode, add capacitors to reduce the noise by filtering the output current as shown in **Figure 32**.

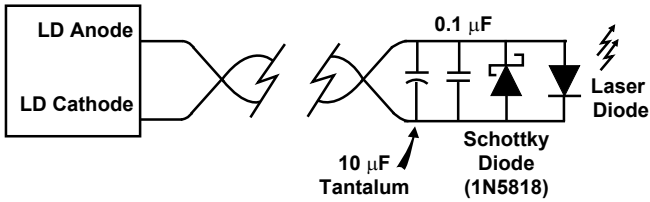

Figure 32. Filter the output when not modulating the laser.

CONVERT CURRENT MONITOR TO 1mV/mA

In order to convert the current monitor to 1mV/mA, see the wiring diagram in **Figure 33**, along with the resistor values (model dependent) in **Table 6**.

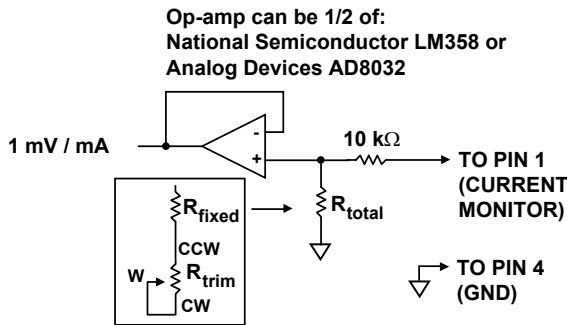

Figure 33. Wire the LDD P as shown to convert the current monitor.

RESISTOR	LDD200	LDD400
R_{total}	869 Ω	1905 Ω
R_{fixed}	750 Ω	1820 Ω
R_{trim}	200 Ω	200 Ω

Table 6. Values of resistors for LDD P model.
All resistors are metal film.

USING A TTL SIGNAL AT MOD INPUT

TTL signals require pre-conditioning. The following circuit filters the TTL signal appropriately (low pass with a corner frequency of 15kHz).

NOTE: With +5V applied at the MOD INPUT, a residual output current will still flow through the laser diode.

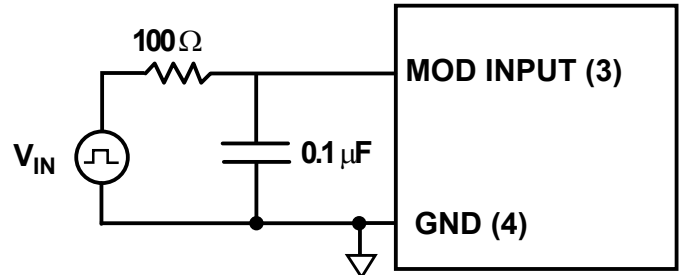

Figure 34. This circuit allows a TTL signal at MOD INPUT.

PERFORMANCE GRAPHS

TEST SETUP

The wiring diagram for testing setup is shown in **Figure 35** below. The Timing Characteristics (**page 6**) and the Typical Performance Graphs (**page 22 and page 23**) data were taken using this setup.

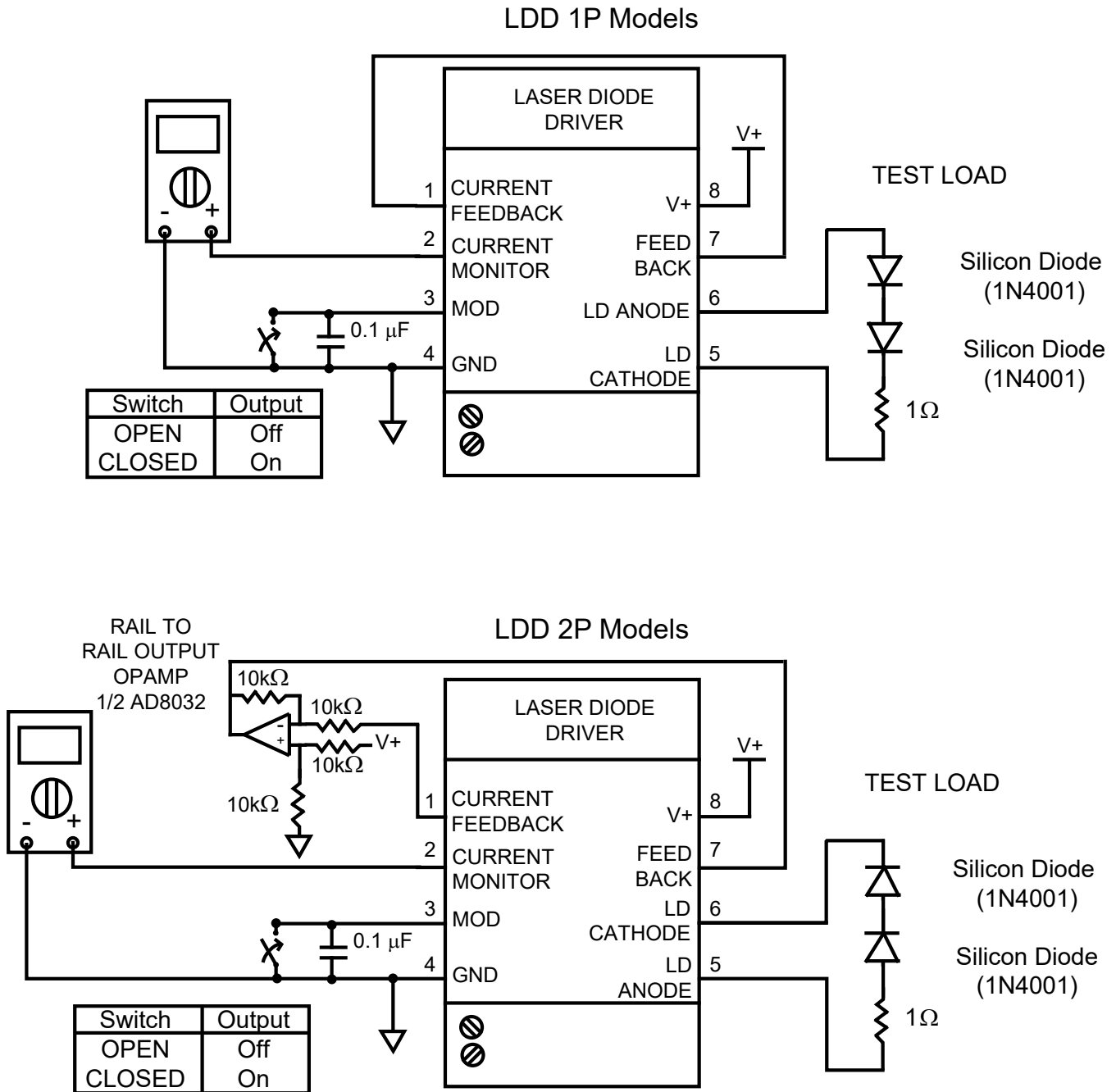

Figure 35. Testing setup used for Timing Characteristics and Performance Graphs.

TYPICAL PERFORMANCE GRAPHS
LDD IP: NOT IN CURRENT LIMIT

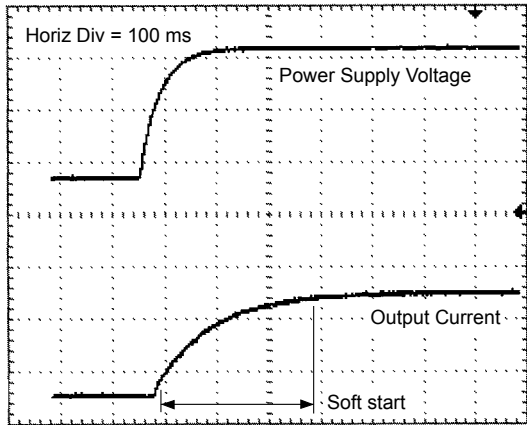

Figure 36. Typical Soft Start Timing (current setpoint at 100% full scale)

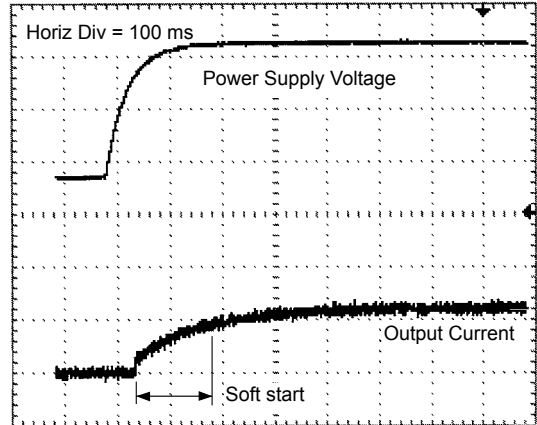

Figure 39. Typical Soft Start Timing (current setpoint at 10% full scale)

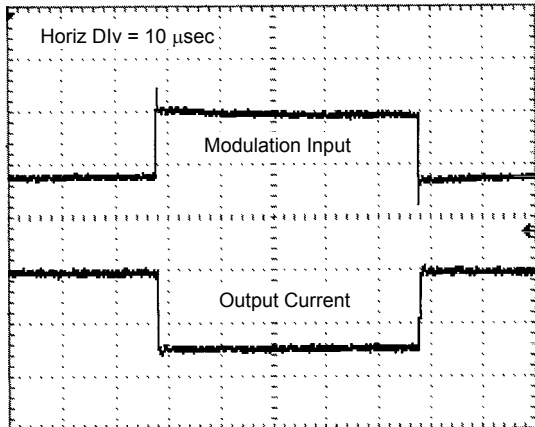

Figure 37. 10 kHz square wave response

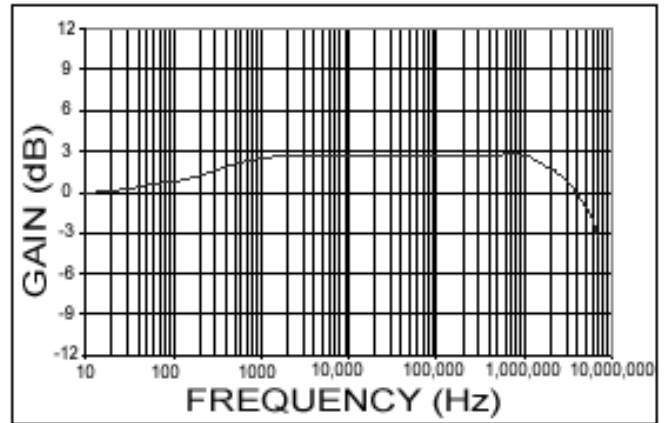

Figure 40. Large signal frequency response (Gain normalized to output at 10 Hz)

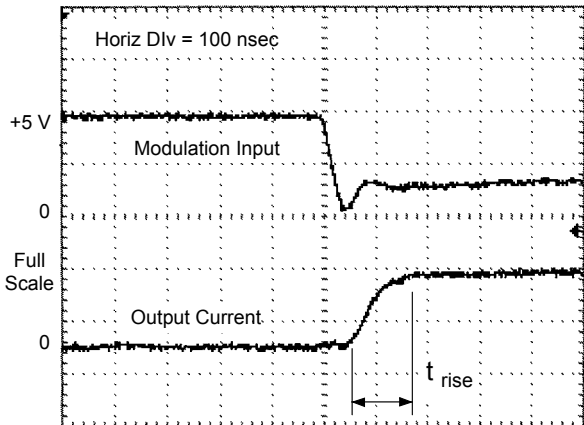

Figure 38. 10 kHz square wave rise time

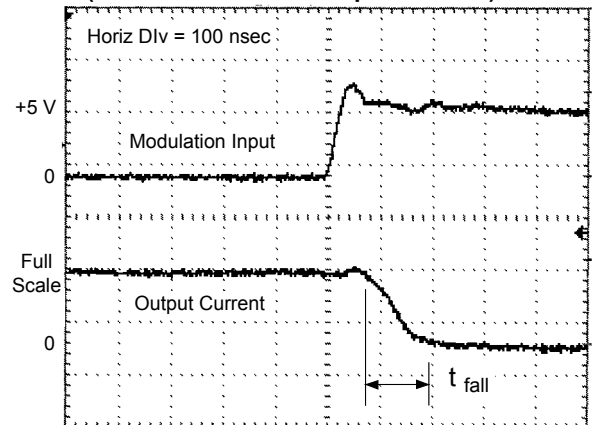

Figure 41. 10 kHz square wave fall time

NOTE: Keep Operating Setpoint Below Current Limit Setting. These graphs do not represent the LDD P performance while the Current Limit Circuit is triggered.

WARNING: The Current Limit Circuit is not an absolute/failsafe clamp. If the operating setpoint exceeds the limit setting, and a fast modulation signal is input, very short overshoots of the current limit are possible (150 nsec). If the photodiode feedback signal is lost or very slow, the LDD P can drive to its maximum output current.

TYPICAL PERFORMANCE GRAPHS
LDD 2P: NOT IN CURRENT LIMIT

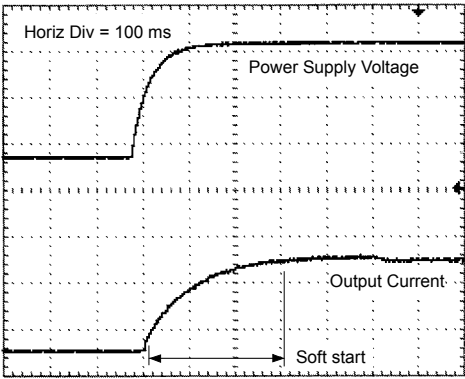

Figure 42. Typical Soft Start Timing (current setpoint at 100% full scale)

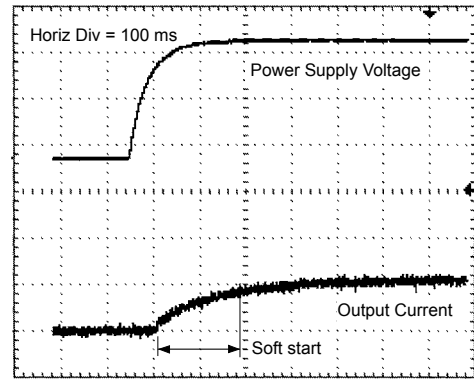

Figure 45. Typical Soft Start Timing (current setpoint at 10% full scale)

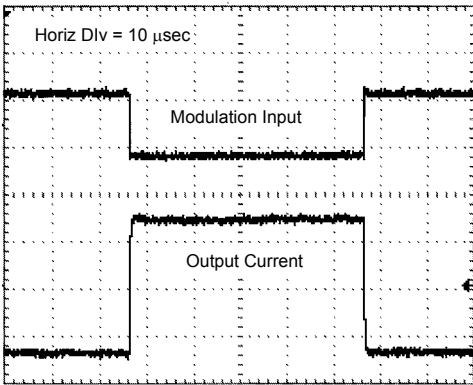

Figure 43. 10 kHz square wave response

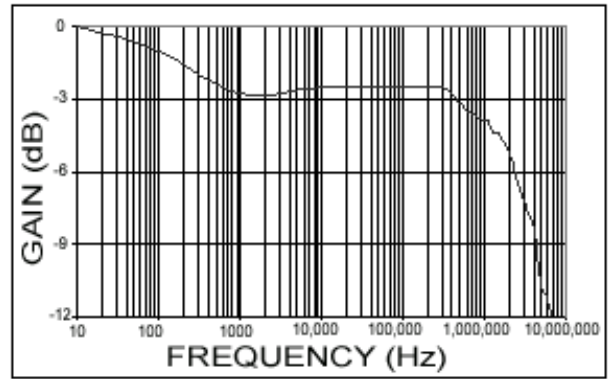

Figure 46. Large signal frequency response (Gain normalized to output at 10 Hz)

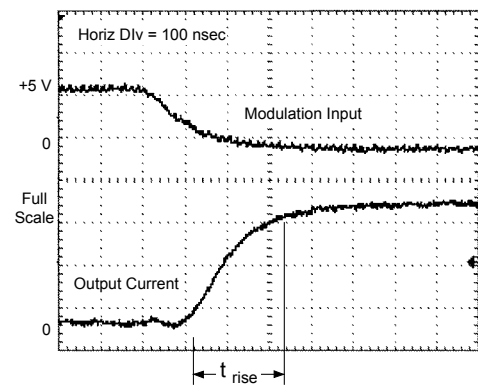

Figure 44. 10 kHz square wave rise time

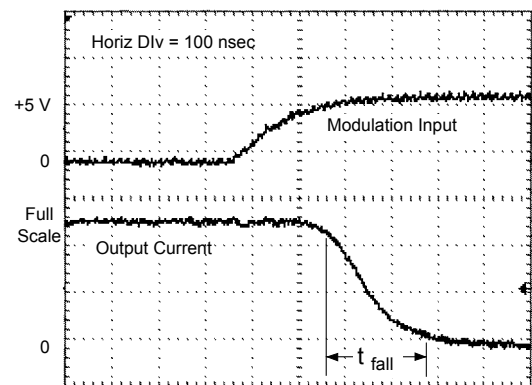

Figure 47. 10 kHz square wave fall time

NOTE: Keep Operating Setpoint Below Current Limit Setting. These graphs do not represent the LDD P performance while the Current Limit Circuit is triggered.

WARNING: The Current Limit Circuit is not an absolute/failsafe clamp. If the operating setpoint exceeds the limit setting, and a fast modulation signal is input, very short overshoots of the current limit are possible (150 nsec). If the photodiode feedback signal is lost or very slow, the LDD P can drive to its maximum output current.

SAFE OPERATING AREA CALCULATION

The Safe Operating Area of the LDD P driver is determined by the amount of power that can be dissipated within the output stage of the driver. If that power limit is exceeded, permanent damage can result.



DO NOT OPERATE THE LDD P DRIVER OUTSIDE OF THE SAFE OPERATING AREA CURVE.

OPERATING THE LDD P DRIVER OUTSIDE OF THE SOA VOIDS THE WARRANTY.

Refer to the Wavelength Electronics website for the most up-to-date SOA calculator for our products. The online tool is fast and easy to use, and also takes into consideration operating temperature.

www.teamwavelength.com/support/design-tools/soa-ld-calculator/

SOA charts are included in this datasheet for quick reference, however we recommend you use the online tools instead.

Follow these steps to determine if the driver will be operating within the SOA.

- Refer to the laser diode datasheet to find the maximum voltage (V_{MAX}) and current (I_{MAX}) specifications
- Calculate the voltage drop across the controller:

Equation 6. $V_{DROP} = V_S - V_{MAX}$
 (V_S is the power supply voltage)

- Mark V_{DROP} on the X-axis, and extend a line upward
- Mark I_{MAX} on the Y-axis, and extend a line to the right until it intersects the V_{DROP} line
- On the X-axis, mark value of V_S
- Extend a diagonal line from V_S to the intersection of the V_{DROP} and I_{MAX} lines; this is the Load Line
- If the Load Line crosses the Safe Operating Area line at any point, the configuration is not safe

If the SOA Calculator indicates the LDD P will be outside of the Safe Operating Area, the system must be changed so that less power is dissipated within the driver. See Wavelength Electronics Application Note [AN-LDTC01: The Principle of the Safe Operating Area](#) for information on shifting the Load Line.

After changing any of the operating parameters, recalculate the SOA to make sure the driver will operate safely. If you have questions, or run into difficulties calculating the SOA, contact Wavelength Electronics for assistance.

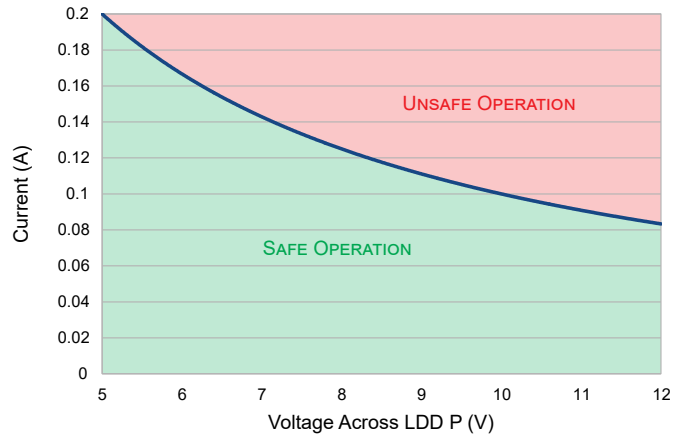

Figure 48. SOA for LDD200 P Series

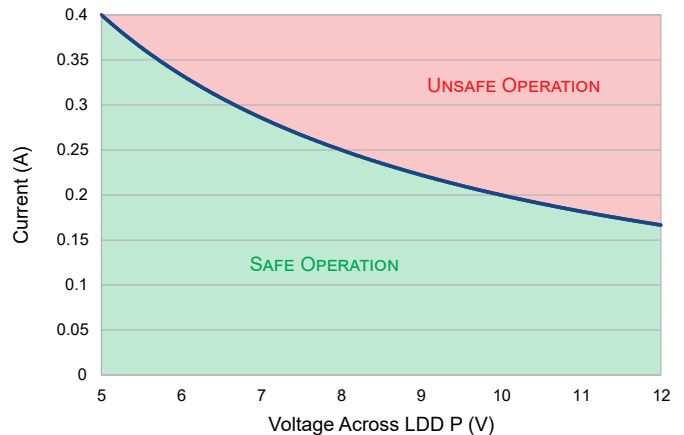

Figure 49. SOA for LDD400 P Series

TROUBLESHOOTING

PROBLEM	POTENTIAL CAUSES	SOLUTIONS
Driver will not switch on	Improperly configured power supply	Carefully check the wiring diagram according to Table 1 or Table 2 , depending on model.
	Pins 3 and 4 not shorted	
Laser output power too low	Laser current setpoint too low	Increase the setpoint either by adjusting the OUTPUT ADJUST trimpot clockwise, or by decreasing the signal voltage on MOD INPUT (pin 3).
	Laser current limit too low	Refer to page 11 for instructions on setting the laser driver current limit.
	Laser driver is compliance limited	Check the laser diode specifications to determine the forward voltage (V_f). Make sure that the LDD P is not compliance limited. Refer to the Electrical Specifications table on page 5 . If the driver is compliance limited, $V+$ may need to be increased. Verify that the LDD P will be operating within the Safe Operating Area if $V+$ is increased.
Modulation is not working	Laser current setpoint is too low	Modulation input on the LDD P is accomplished by <i>subtracting</i> from the laser setpoint. If the current setpoint is too low, the modulation can drive the current to the laser to zero. If the current setpoint is set to zero, no modulation is allowed.

CABLING SPECIFICATIONS

WCB201 – LDD P to 3 PIN (9 mm) LASER DIODE

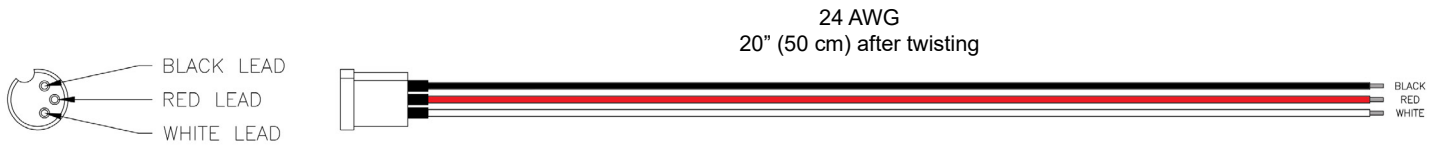

MECHANICAL SPECIFICATIONS

LDD P

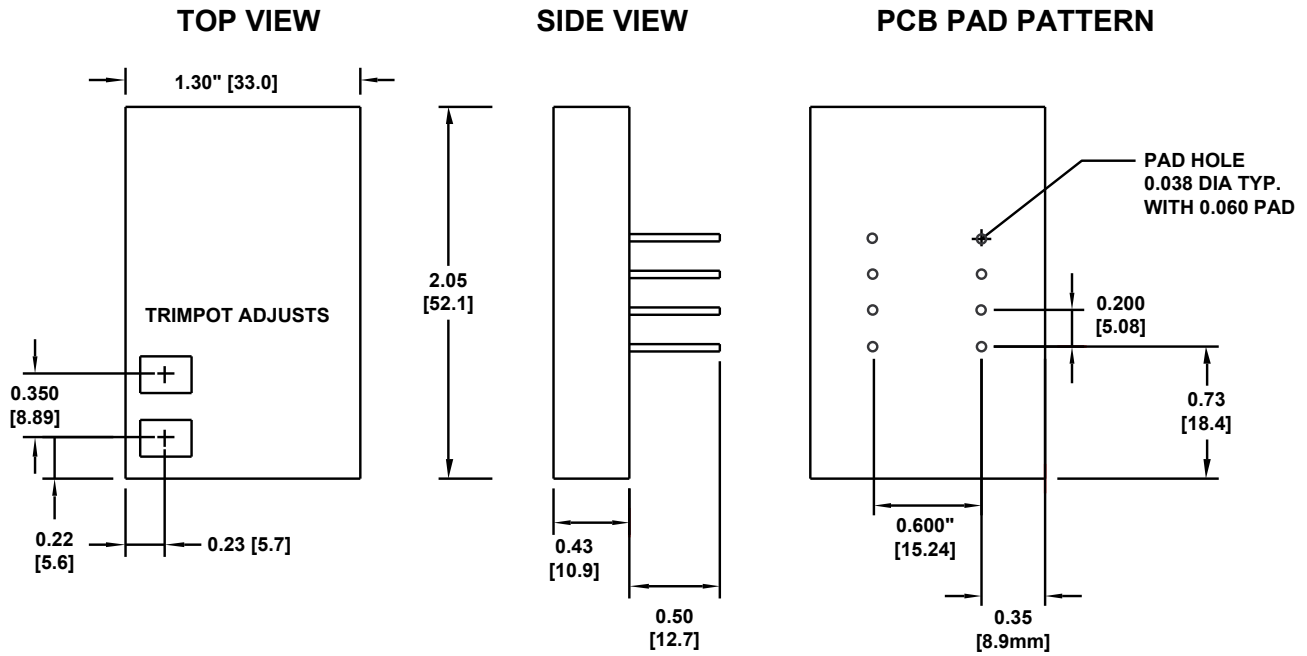

Figure 50. LDD P Series Laser Diode Driver Mechanical Dimensions

LDDEVALP

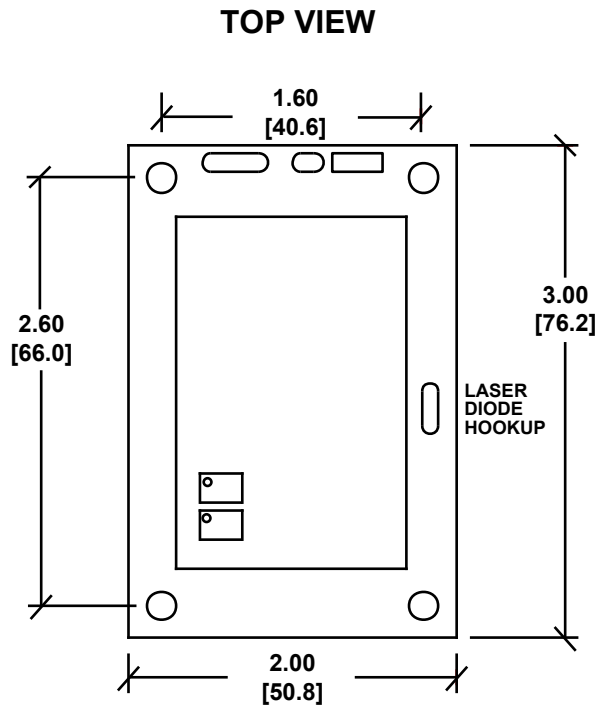

Figure 51. LDD P Series Laser Diode Driver Evaluation Board Dimensions

All Tolerances $\pm 5\%$; units in inches [mm]

CERTIFICATION AND WARRANTY

CERTIFICATION

Wavelength Electronics, Inc. (Wavelength) certifies that this product met its published specifications at the time of shipment. Wavelength further certifies that its calibration measurements are traceable to the United States National Institute of Standards and Technology, to the extent allowed by that organization's calibration facilities, and to the calibration facilities of other International Standards Organization members.

WARRANTY

This Wavelength product is warranted against defects in materials and workmanship for a period of one (1) year from date of shipment. During the warranty period, Wavelength will, at its option, either repair or replace products which prove to be defective.

WARRANTY SERVICE

For warranty service or repair, this product must be returned to the factory. An RMA is required for products returned to Wavelength for warranty service. The Buyer shall prepay shipping charges to Wavelength and Wavelength shall pay shipping charges to return the product to the Buyer upon determination of defective materials or workmanship. However, the Buyer shall pay all shipping charges, duties, and taxes for products returned to Wavelength from another country.

LIMITATIONS OF WARRANTY

The warranty shall not apply to defects resulting from improper use or misuse of the product or operation outside published specifications. No other warranty is expressed or implied. Wavelength specifically disclaims the implied warranties of merchantability and fitness for a particular purpose.

EXCLUSIVE REMEDIES

The remedies provided herein are the Buyer's sole and exclusive remedies. Wavelength shall not be liable for any direct, indirect, special, incidental, or consequential damages, whether based on contract, tort, or any other legal theory.

REVERSE ENGINEERING PROHIBITED

Buyer, End-User, or Third-Party Reseller are expressly prohibited from reverse engineering, decompiling, or disassembling this product.

NOTICE

The information contained in this document is subject to change without notice. Wavelength will not be liable for errors contained herein or for incidental or consequential damages in connection with the furnishing, performance, or use of this material. No part of this document may be translated to another language without the prior written consent of Wavelength.

SAFETY

There are no user-serviceable parts inside this product. Return the product to Wavelength Electronics for service and repair to ensure that safety features are maintained.

LIFE SUPPORT POLICY

This important safety information applies to all Wavelength electrical and electronic products and accessories:

As a general policy, Wavelength Electronics, Inc. does not recommend the use of any of its products in life support applications where the failure or malfunction of the Wavelength product can be reasonably expected to cause failure of the life support device or to significantly affect its safety or effectiveness. Wavelength will not knowingly sell its products for use in such applications unless it receives written assurances satisfactory to Wavelength that the risks of injury or damage have been minimized, the customer assumes all such risks, and there is no product liability for Wavelength. Examples of devices considered to be life support devices are neonatal oxygen analyzers, nerve stimulators (for any use), auto-transfusion devices, blood pumps, defibrillators, arrhythmia detectors and alarms, pacemakers, hemodialysis systems, peritoneal dialysis systems, ventilators of all types, and infusion pumps as well as other devices designated as "critical" by the FDA. The above are representative examples only and are not intended to be conclusive or exclusive of any other life support device.

REVISION HISTORY

DOCUMENT NUMBER: LDD200P-00400

REV.	DATE	CHANGE
F	May 2011	Updated to include R_{4a} and Mod Input Safe Range
G	December 2011	Updated Type C Laser Quick Connect Diagram
H	January 2013	Updated Type C Laser Quick Connect
I	April 2018	Updated to new format. Expanded Constant Current instructions.