

MEMS TUNABLE OPTICAL FILTER

OVERVIEW

Sercalo's Tunable Optical Filter is based on MEMS technology and is designed for ITU O, C and L band with 50 GHz or 100 GHz channel spacing. The highly reliable tuning mechanism uses an integrated micro-mirror with switching time below 50 ms and insertion loss below 3 dB.

The bare Tunable Filter component (BCTF variant) measures only 43 x 11 x 9.5 mm³ and is ideal for applications requiring reduced size and weight. The miniature package withstands rugged environments and is well suited for direct mounting on printed circuit boards.

An interface board with UART and I²C/SMBus is also available.

The component is compliant to Telcordia 1221 reliability standards and ROHS requirements 2015/863/EU.

FEATURES

- Small 43x11x9.5 mm³ body size
- Low insertion loss
- Also available with UART and I²C/SMBus interface board

APPLICATIONS

- Reconfigurable optical add/drop multiplexers
- Optical sensor interrogators
- Optical power monitors
- Low cost spectrometers

Contact:
Sercalo Microtechnology Ltd.
 Landstrasse 151
 9494 Schaan - Principality of Liechtenstein
 Tel. +423 237 57 97 Fax. +423 237 57 48
<http://www.sercalo.com> e-mail: info@sercalo.com

ORDERING INFORMATION

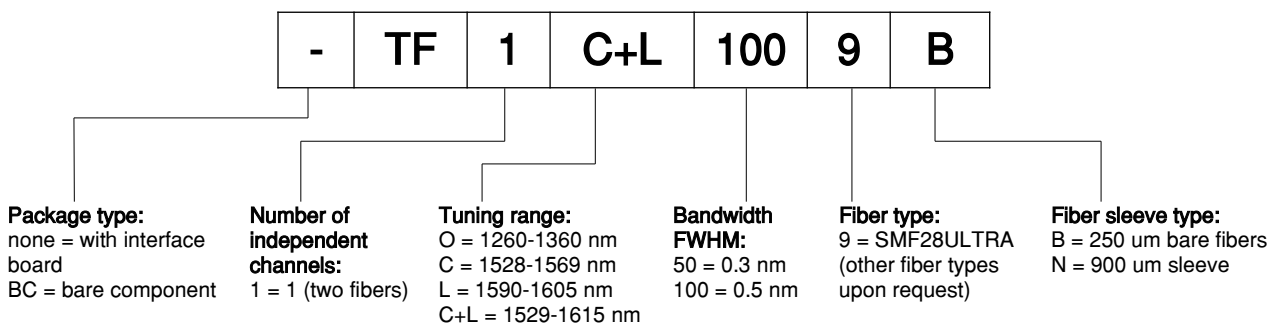

DESCRIPTION

Sercalo's Tunable Filter is composed by an optical system where light coming from the input fiber is collimated on a fused silica grating. The grating diffracts the light with a distinct angle for each wavelength. Light is then reflected by a MEMS mirror onto the output collimator which only couples a small fraction of it into the output fiber. By modifying the MEMS mirror tilt angle user can chose the central wavelength of the filter.

TECHNICAL SPECIFICATIONS

	<i>Unit</i>	<i>Min</i>	<i>Typ</i>	<i>Max</i>
Optical specifications				
Tuning range (O band variant)	nm	1260		1360
Tuning range (C band variant)	nm	1528		1569
Tuning range (L band variant)	nm	1570		1615
Tuning range (C+L band variant)	nm	1529		1615
Insertion loss ¹	dB		2.5	4.0
Variant TFxx50	Full bandwidth @ 0.5 dB	nm	0.12	
	Full bandwidth @ 3 dB	nm	0.3	
	Full bandwidth @ 10 dB	nm	0.6	
	Full bandwidth @ 20 dB	nm	0.8	
Variant TFxx100	Full bandwidth @ 0.5 dB	nm	0.2	
	Full bandwidth @ 3 dB	nm	0.5	
	Full bandwidth @ 10 dB	nm	1.0	
	Full bandwidth @ 20 dB	nm	1.2	
Return loss	dB	30		
Wavelength repeatability	nm		0.01	
Wavelength temperature dependence	pm/°C		1	5
Switching time	ms		10	50
PDL	dB		0.3	
Durability	cycles	No wear out		
Side Mode Suppression Ratio (SMSR)	dB	25		
Electrical specifications (optical component)				
Driving voltage	V	0		60
Driving voltage damage threshold	V			65
Electrostatic discharge tolerance ²	V			70
Electrical specifications (control board)				
Supply voltage	V	4.75	5	5.25
Power consumption (idle)	W		0.2	
Power consumption (operating)	W		1	
UART speed	baud	9600		115200
SMBus/I ² C bus speed	kHz			400
Input logic level low	V		0	0.6
Input logic level high	V	2.4	5	
Output logic level low	V		0	0.6
Output logic level high	V	2.6	3.3	
Reset inactive voltage ³	V	2.4	5	
Reset active voltage	V		0	0.9
Reset pulse duration	µs	15		
Package				
Operating temperature	°C	0		70
Storage temperature	°C	-40		70
Operation humidity (non condensing)	% r.h.	0		95
Pigtail length	cm	50		100
Size (optical component)	mm	43.3 x 11.2 x 9.5		
Size (with control board)	mm	45 x 23 x 10		
Weight	g	75		
ROHS Compliance		2015/863/EU (no exceptions)		

¹Value @ 25 °C, without connectors. ²The bare optical component is not protected against ESD and need special care during handling.

³ Through onboard pull-up resistor.



BCTF – BARE OPTICAL COMPONENT (DIMENSIONS IN MILLIMETERS)

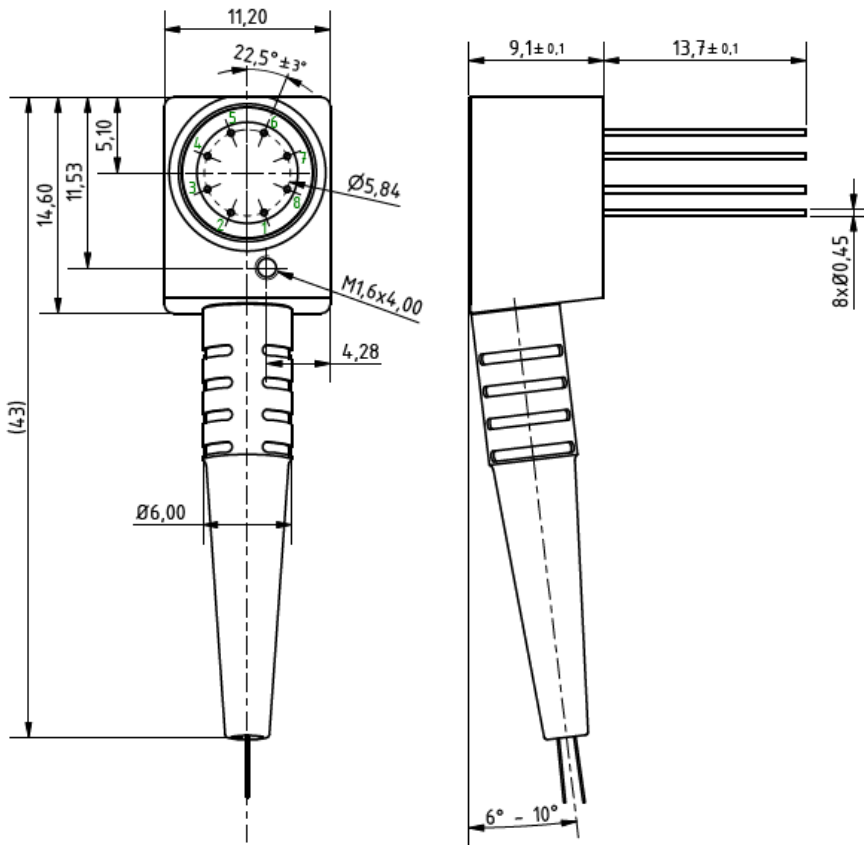

Pin number	Description
1	Not connected
2	Not connected
3	Y+
4	Not connected
5	X-
6	Y-
7	Common reference
8	X+

TF – WITH CONTROL BOARD (DIMENSIONS IN MILLIMETERS)

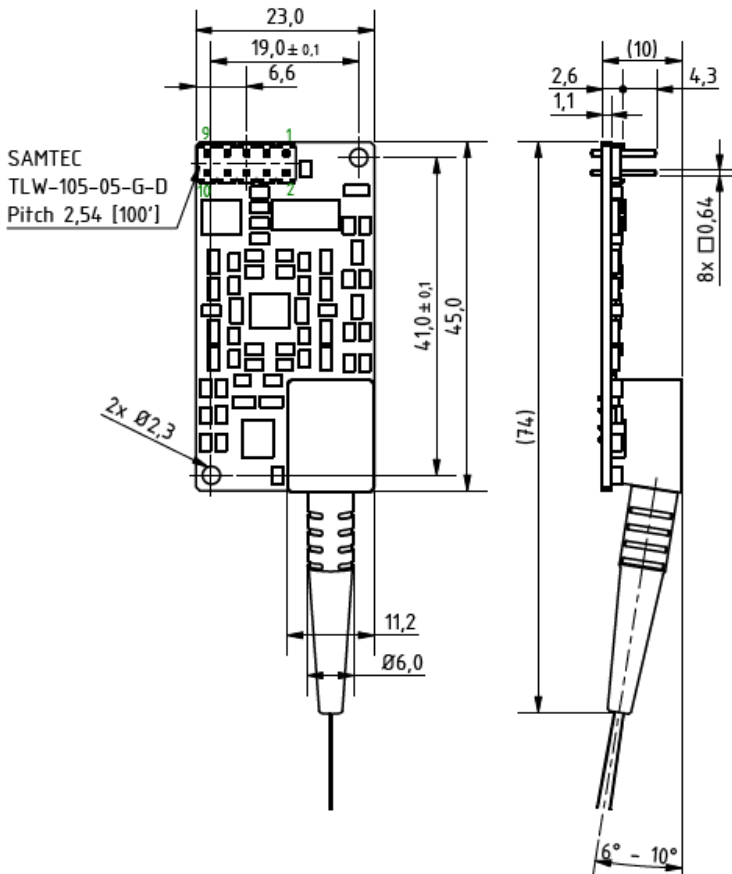

Pin number	Description
1	Ground (GND)
2	Supply voltage (V _{DD})
3	Reserved
4	UART Tx
5	Reserved
6	UART Rx
7	Reset (/RST)
8	SMBus/I ² C SDA
9	SMBus/I ² C SCL
10	Ground (GND)

TUNABLE FILTER OPERATING PRINCIPLE

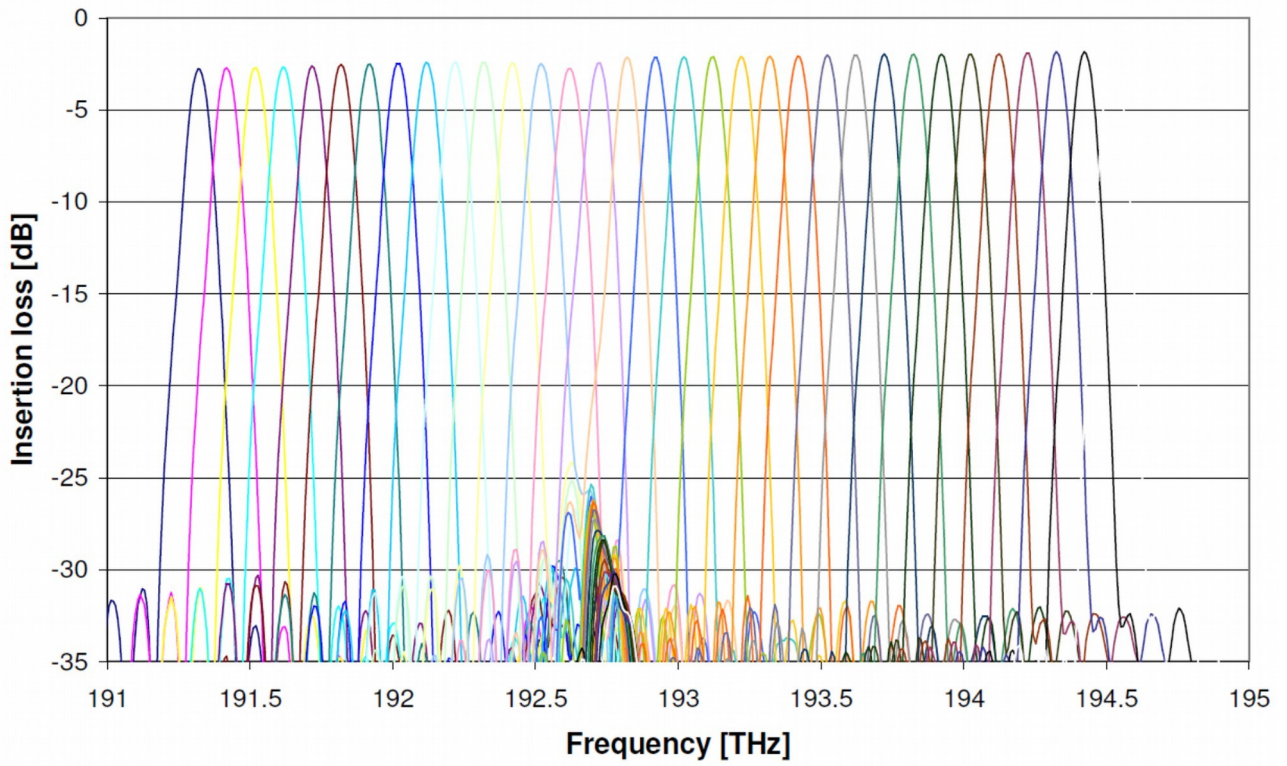
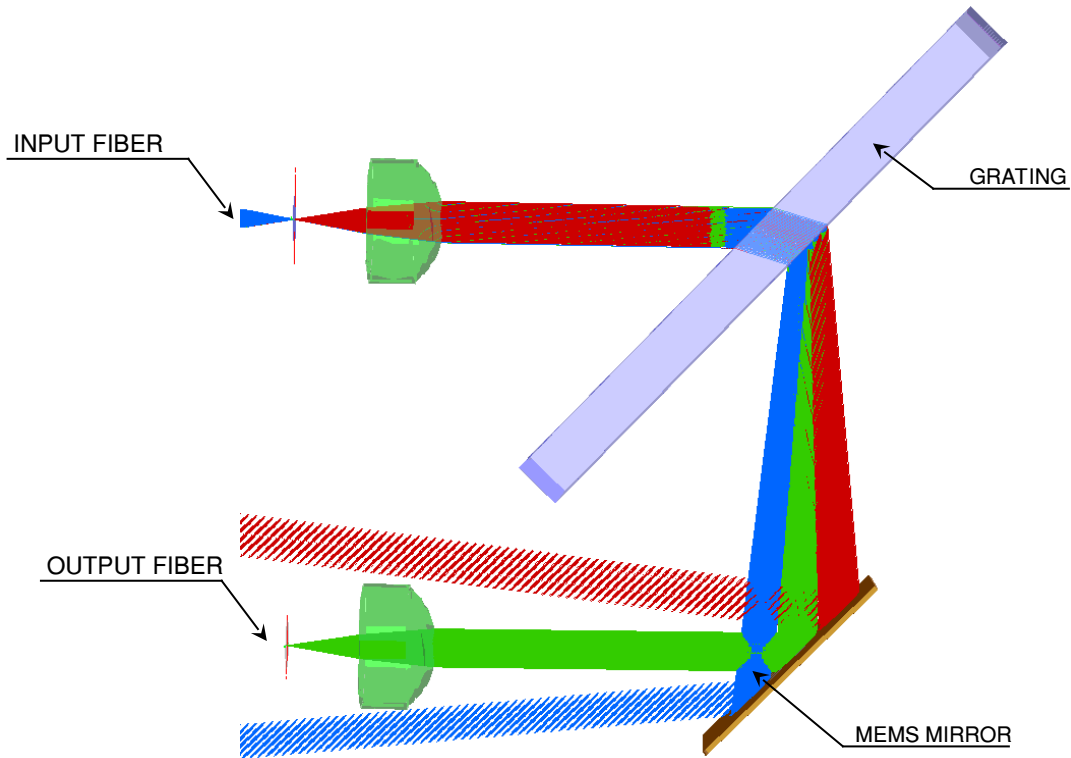

Figure 1 – Example of custom grid: 100GHz spacing, 32 channels

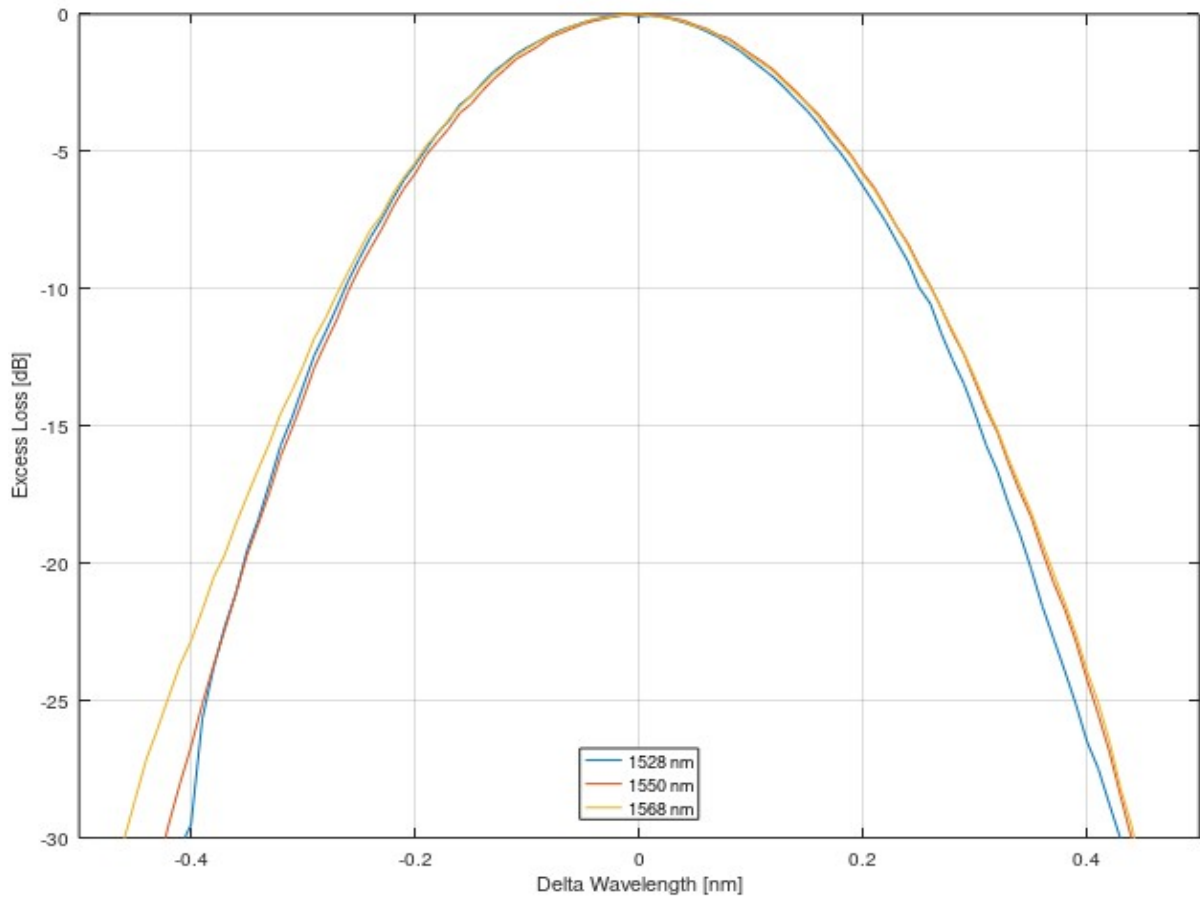

Figure 2 – Typical filter shape (50 GHz, C band variant)

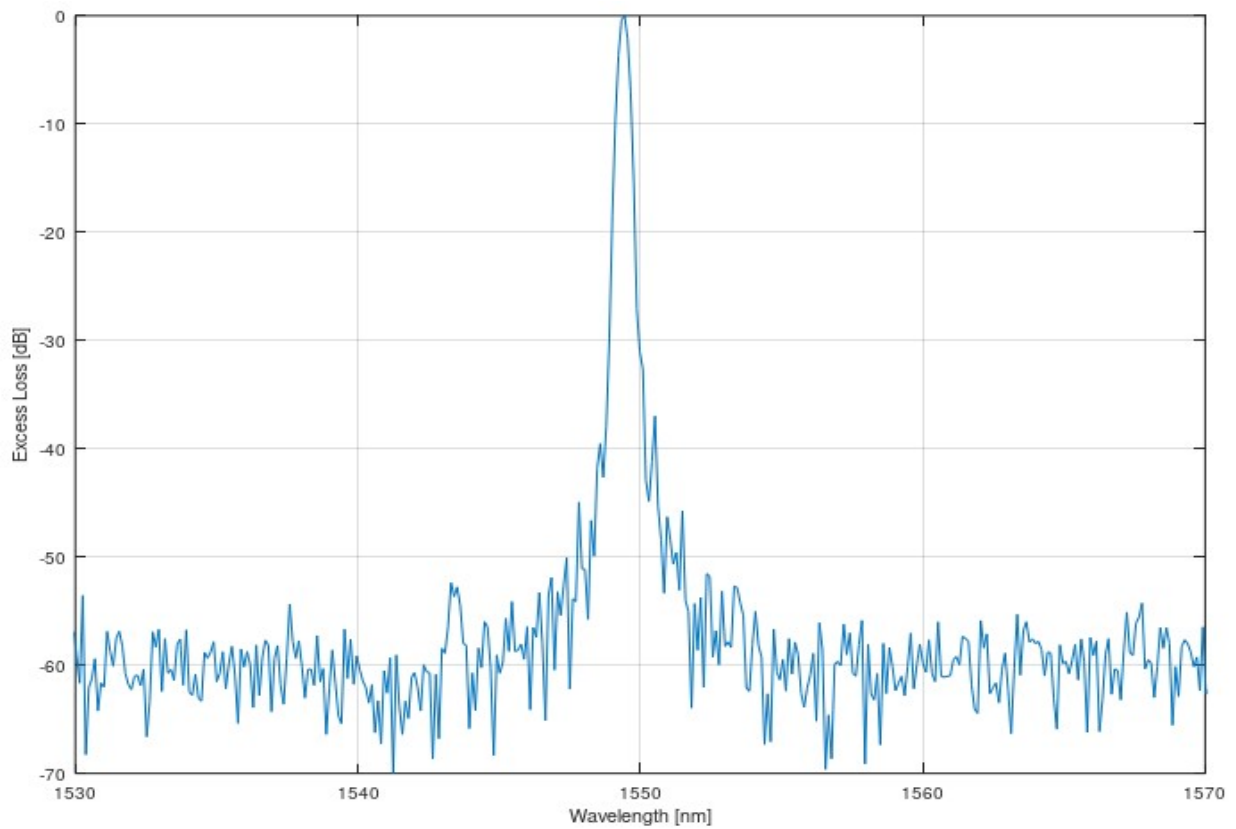

Figure 3 – Typical filter shape over the whole tuning range (C band variant)

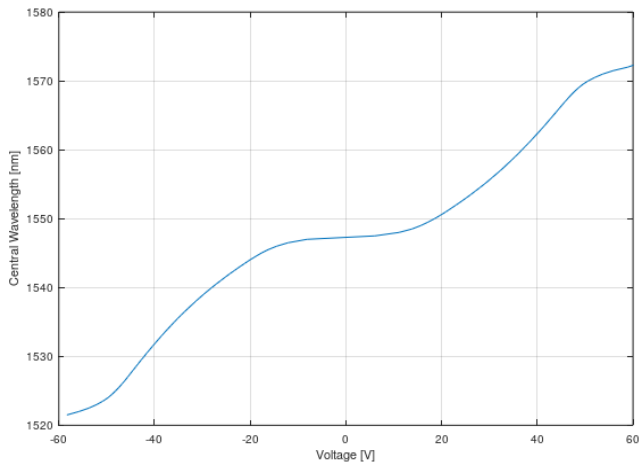

Figure 4 – Typical Central Wavelength vs. Voltage (C band variant)

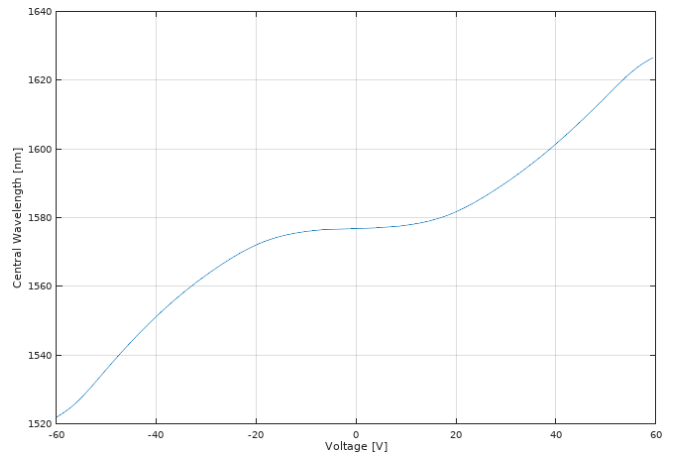

Figure 5 – Typical Central Wavelength vs. Voltage (C+L band variant)