



Before use, please take the time to read this datasheet and make sure you understood the advices and caution of use.



Security of the user

- Do not watch directly the beam of light or through any optical instrument.
- Avoid any contact with the LEDs or its lens.
- Code IP40: protected against solid corpses larger than 1 mm and non-protected against water intrusion.
- Use the product in an environment where the working temperature is between +15°C and +35°C and there is little humid air (<80%): if those conditions are not respected the product can be damaged.
- Do not use the product in an environment where smokes and oil vapors are present.
- Never try to repair by yourself any potential damages on the product.
- Make sure to use the right power supply before connecting the product.
- Do not reverse the electrical polarity – check your connections and the conventions before turning on the product.
- Make sure you have the correct connector to link the product to the power supply.

Any incorrect use cancels the warranty.

Table of contents

| | |
|---|----|
| Eyes & Skin Safety | 3 |
| Legal obligations | 4 |
| Possible damages on health | 4 |
| Protective equipment | 5 |
| Technical Overview | 8 |
| Product reference | 9 |
| Optical characteristics | 10 |
| Mechanical dimensions | 11 |
| How to use: with the power supply | 12 |
| How to use: without the power supply UPOWER™ | 14 |
| Signals | 15 |
| Accessories | 16 |
| “SMART” Option | 17 |



Eyes & Skin Safety



UWAVE products come under the standard DIN EN 62471:2008 which classified sources of optical radiation into risk groups subject to their potential photo biological hazard. Due to the emission of high UV irradiation, our products belong to Risk Group 3 (hazardous even for momentary exposure) therefore special safety measures, detailed in the following, must be observed.



To protect the eyes and skin staff everyone in the area must wear **protective equipment**. Protective **goggles** should comply with the standard EN 170 (Personal eye-protection - Ultraviolet filters - Transmittance requirements and recommended use). The goggles must protect eyes against direct and side irradiation.



Don't look directly at the product's output window because of a risk of becoming blind.
Don't expose skin too long without protection to avoid skin burning or cancer.



Due to the high emission power, the area near the LEDs can reach high temperature during operation.
Avoid touching directly the product and especially the output window.



Legal obligations

Under the law at present, workers' exposure must be lower than the Exposure Limit Value (Directive 2006/25/EC of the European Parliament). Depending on the wavelength of the product and the body part insolated, **Limit Values are summarized in the tables below:**

| | Eye | Skin |
|-----------------------------|-------------------------|------------------------------|
| Wavelength | 315 – 400 nm (UVA) | 180 – 400 nm (UVA, UVB, UVC) |
| Exposure Limit Value | 10 000 J/m ² | 30 J/m ² |

Case study with a LED at 365 nm with an Optical Power of 10 mW/cm²:

For the **eyes**, the maximal exposure time (Δt), the Exposure Limit Value (*ELV*), and the Optical Power (*P*) of a UV product are linked by the formula:

$$\Delta t = \frac{ELV}{P}$$

For **skin**, the Optical Power is normalized by skin's sensitivity factors for each wavelength.

The maximal exposure time per day is calculated below:

| | Eyes | Skin |
|--|-----------------------|------------------------|
| Optical Power (normalized for skin) | 10 mW/cm ² | 4,7 μW/cm ² |
| Maximal exposure time per day | 1 min 40 s | 12 min |

Therefore, with a UV product with an optical power of 10 mW/cm², the Exposure Limit Value per day is **reached in 2 minutes for eyes and 12 minutes for skin** without any safety equipment. Therefore, protective equipment is needed.



Possible damages on health

Effects on skin along unprotected UV exposure

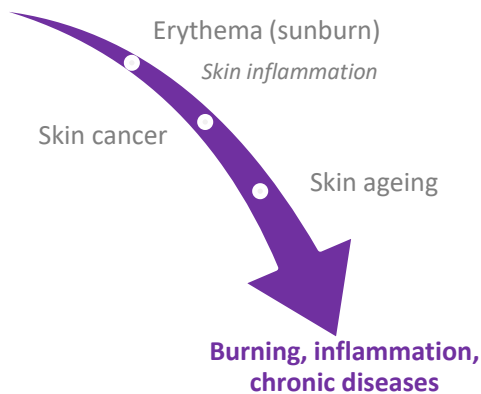

Effects on eyes along unprotected UV exposure

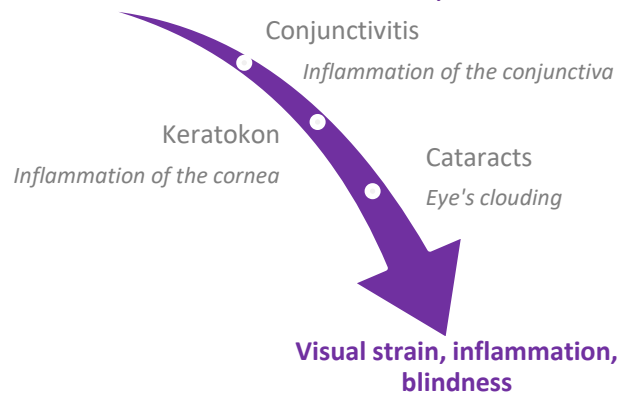



Protective equipment



Eyes protection



Safety goggles prevent UV damages to eyes.

REF: UGLASS-02

- Certified NF EN 170 absorbing 99,9% of UV radiation and visible light up to 532nm
- Protect against side irradiation
- Resist to chemical products and scratches

Beyond 2 minutes per day of eye UV LED exposure at 10 mW/cm², protective goggles are necessary according to the European Directive 2006/25/EC.



Safety face shield prevents UV damages to eyes and skin's face.

REF: UMASK-01

- Certified NF EN 170 absorbing 99,9% of UV radiation and visible light up to 400nm
- Protect against side irradiation
- Resist to scratches

Beyond 12 minutes per day of face UV LED exposure at 10 mW/cm², protective mask is necessary according to the European Directive 2006/25/EC.



Body protection



Safety gloves prevent UV damages to exposed skin.

REF: UGLOVE-01

- High protection against UV radiation
- Resist to chemical products and scratches

Beyond 12 minutes per day of hands UV LED exposure at 10 mW/cm², protective gloves are necessary according to the European Directive 2006/25/EC.



Safety jacket and trousers prevent UV damages to exposed skin, especially arms & legs.

- Certified UPF 50+ absorbing more than 90% of UV radiation
- Durable and resistant

REF (jacket): UJACK-01

REF (trouser): UTROUS-01

Beyond 12 minutes per day of arms & legs UV LED exposure at 10 mW/cm², protective clothes are recommended according to the European Directive 2006/25/EC.



Protection suit prevents UV damages to entire body, especially neck.

REF: USUIT-01

- Certified UPF 50+ absorbing more than 90% of UV radiation
- Resist to chemical products

Beyond 12 minutes per day of neck UV LED exposure at 10 mW/cm², protective suit is recommended according to the European Directive 2006/25/EC.



UV source isolation



UV shields are protective windows which isolate the UV insulated zone to protect all workers around.

They are made to measure to fit with your constraints.

REF: USHIELD-01

Beyond 2 minutes per day of eye UV LED exposure and 12 minutes of skin UV exposure at 10 mW/cm², protective shields are necessary to protect staff without safety equipment according to the European Directive 2006/25/EC.



Warning stickers



Warning stickers inform workers of radiation danger and invite them of wearing protection equipment. They are available in 3 sizes:

- 55 mm x 25 mm
- 165 mm x 75 mm
- 290 mm x 130 mm

REF: USTICK-01

REF: USTICK-02

REF: USTICK-03



Expertise

Our UV LED experts from UWAVE can come and check your production lines to:



Measure UV irradiance to **determine the maximum UV personal exposure time** compared with limits (European Directive 2006/25/EC)







Determine the most **adapted solution** to protect workers' eyes and skin.



Contact us to get our expertise. We will find together the equipment which fits with your application.



Technical Overview

| | | UBAR™ |
|---|----------------------------|---------------------------------------|
| Electronics  | Power supply | 48V DC |
| | Illumination mode | Continuous with a DIM process [0-10V] |
| | Connector | SubD 13W3 |
| | Power consumption | Max 160 W |
| Optics  | Wavelength | 365 or 385 or 395 or 405 nanometers |
| | Irradiance | 500 mW/cm ² |
| Mechanics  | Width & Height | 72mm x 208 mm |
| | Length | 210 mm |
| | Material | Device body: Aluminum alloy |
| | Weight | 2,0 kg |
| Thermal  | Cooling system | Active air cooling with fans |
| Environment  | Working temperature | +15°C to +35°C |
| | Working Humidity | < 80% for temp < 35°C |
| | IP Code | IP40 |



Product reference

Wavelength (nm)

UBAR - XXX

- 365
- 385
- 395
- 405



Optical characteristics

Spectra

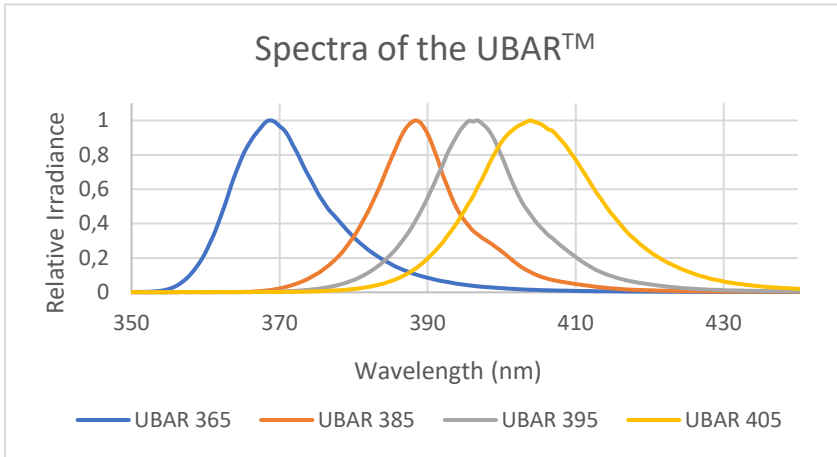

| | Pic Wavelength | Full width at half maximum |
|-----------------|----------------|----------------------------|
| UBAR 365 | 368 nm | 14 nm |
| UBAR 385 | 388 nm | 10 nm |
| UBAR 395 | 397 nm | 14 nm |
| UBAR 405 | 404 nm | 18 nm |

Photometry

In the following graph, the area exposed is the area where the irradiance is higher than 50% of the maximum irradiance.

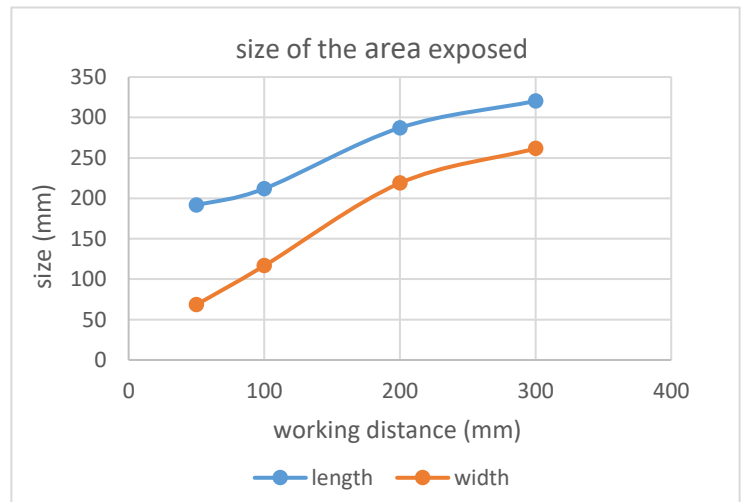
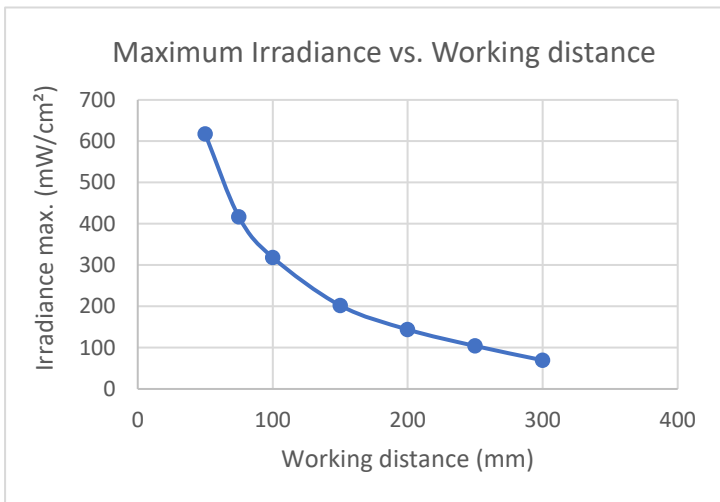
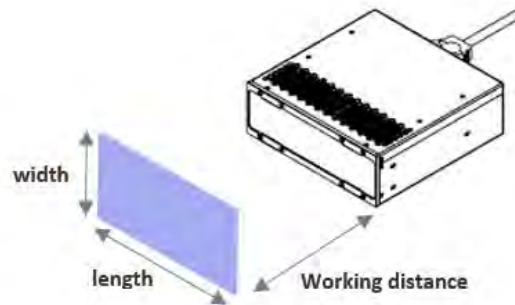

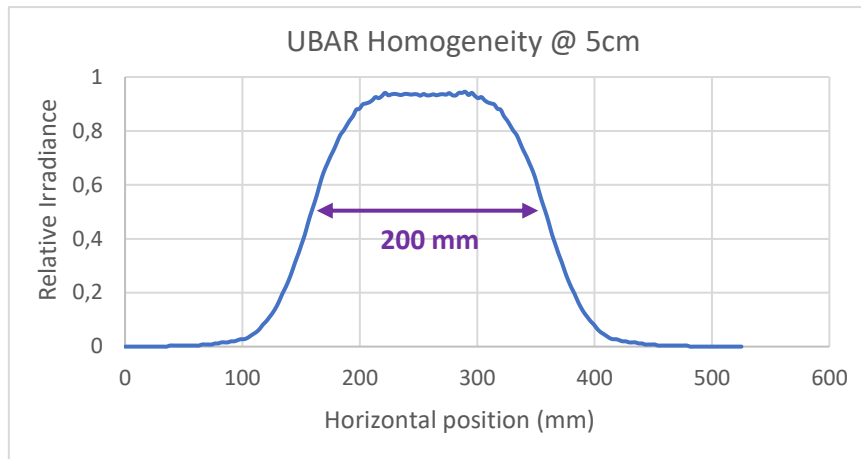

This figure is plotted for measurements of irradiance taken along the length of the area exposed



Mechanical dimensions

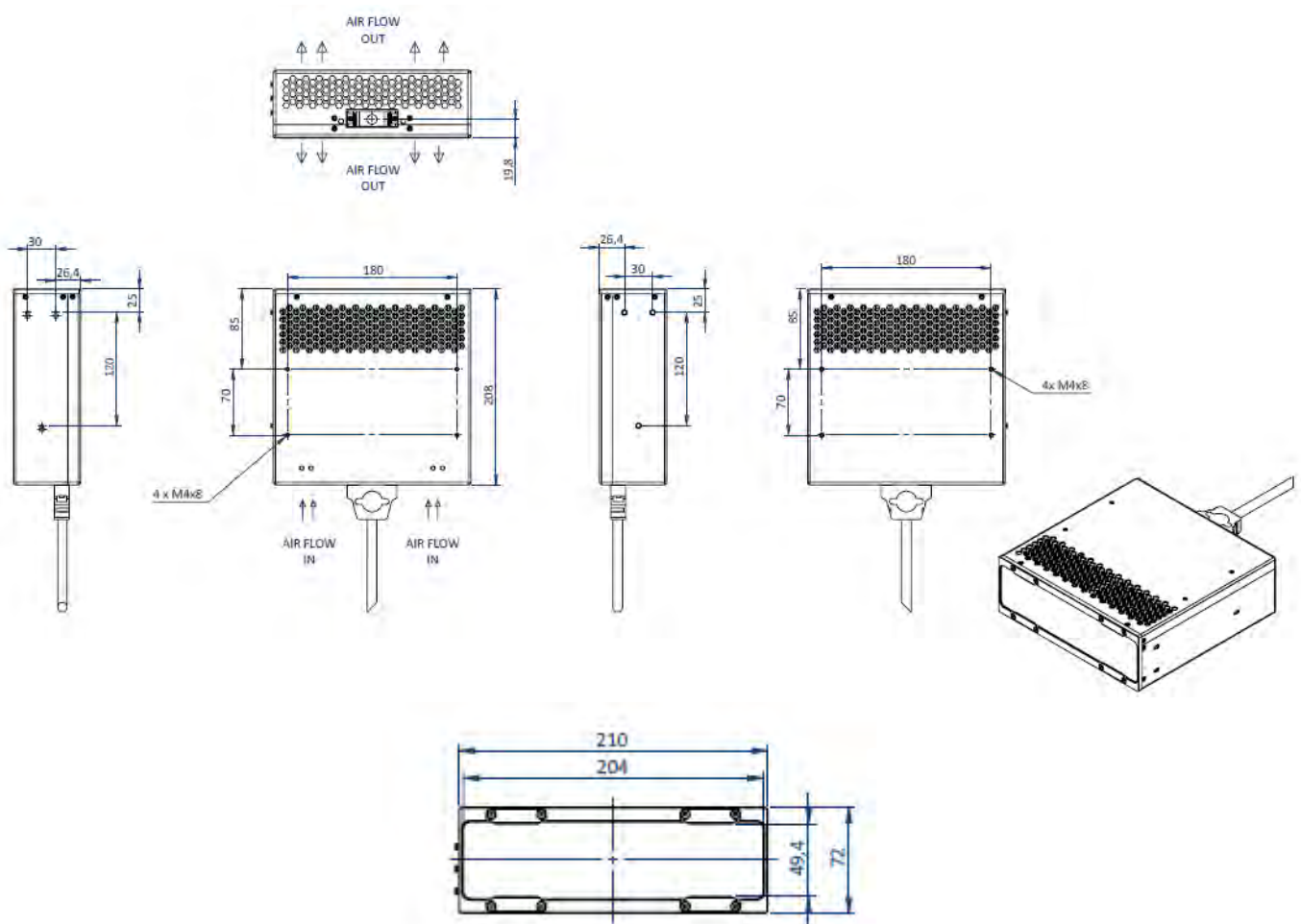



How to use: with the power supply

The UBAR™ can be provided with its power supply UPOWER™

| Steps | Illustrations |
|---|--|
| <p>Fix the product using the dimensions given in the “mechanical considerations” part (pay attention to leave a 10 cm space next to mechanicals holes for ventilation).</p> | |
| <p>Connect the cable SubD13W3 between the UBAR™ and the UPOWER™</p> | <p style="text-align: center;">SubD Connector</p>  |
| <p>Plug the UPOWER to a 230V outlet</p> |  |
| <p>The UBAR™ is ready to be used. To turn the UBAR™ ON, you can either use the buttons ON on the UPOWER, or connect the UPOWER to your PLC</p> | <p style="text-align: center;">STOP button ON button</p>  |
| <p>How to choose the light intensity Use the light intensity controller buttons on the UPOWER to control the light intensity from 20% to 99%</p> | <p style="text-align: center;">Light intensity controller</p>  |

How to choose the exposure time

Use the TIMER interface on the UPOWER to choose the exposure time. The red timer is fixed, and the orange timer is the one that you can change. To validate the time, push the reset button on the timer.

How to lock the UPOWER

Turn the lock key in order to lock the timer configuration. The word "LOCK" appears on the timer screen.



*The version of the UPOWER™ is not furnished with the product



How to use: without the power supply UPOWER™

To connect the product into an automate, use the cable by following the board below.

SubD13W3
Connector

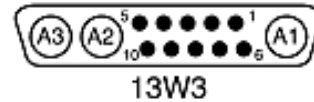

Female SubD 13w3 Connector

| Cable number/Color | Pin number | In / Out signal | Designation | Signal |
|-------------------------|------------|-----------------|-------------------------|--|
| 1 | A1 | In | Power supply + | 48V |
| 2 | A3 | In | Common Ground | 0V |
| 3 | Pin 1 | In | Intensity Control - DIM | 0-10V or look at the graph in section "signals" |
| 5 | Pin 6 | Out | Temperature Default | 0V to 6V: Fault / 16V to 24V: No Fault |
| 6 | A3 | In | Common ground | 0V |
| 7 | Pin 4 | In | Enable + | Dry contact CLOSED: UV emission allowed; OPEN: UV emission stopped |
| 8 | Pin 5 | In | Enable - | |
| Yellow and Green | | | Protective Ground | |

For more details about the several signals emitted, check out the section "signals"



Signals

Intensity Control

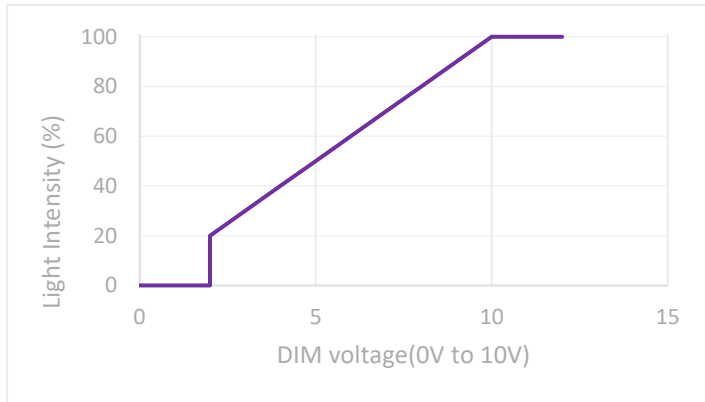

The UBAR™ is supplied with a 48V constant voltage source.

Using the DIM pin, the light intensity can be controlled:

- 0V – OFF (0%)
- 2V to 10V – ON 20% to 100%
- 10V to 24V – ON (100%)

Max DIM power consumption: 5 mW

Temperature Default

If the temperature of the LED is too high, probably because the cooling system has a problem, the product puts itself in temperature safety in order to prevent any damage on the LEDs.

- The LED of temperature state turn red
- A signal is sent to the automate

Status LEDs



Two status LEDs 'Power' and 'Temp' can be found on both sides of the SubD connector. This LEDs give information about the proper functioning of the product.



| STATUS | MEANING |
|-------------|--|
| POWER off | The product is not under voltage |
| POWER red | The product is under voltage but do not emit UV light |
| POWER green | The product is emitting UV light |
| TEMP green | The temperature inside the product is OK: the product can be turned on |
| TEMP red | The temperature of the LED is too high for the product to be turned on |



Accessories

| Description and Photo | Description |
|--|--|
| <p>Cables for the UBAR™</p>  | <p>Both sides connectors (UPOWER™ link):</p> <p style="text-align: right;">2 } Reference: UCAB-SUBD-FD-5-D-L5 } Depending on 10 } the length you want (in meters)</p> <p>One side with bare wire (towards automate):</p> <p style="text-align: right;">2 } Reference: UCAB-SUBD-FM-5-DD-L5 } Depending on 10 } the length you want (in meters)</p> |
| <p>UPOWER™</p>  | <p>We are able to provide you with any kind of power supply you need, different IHM, power, control and connectors.</p> <p>To build the one adapted to your needs please contact us.</p> |



“SMART” Option

The “SMART” option for the UBAR is made in order to know if a LED is broken in the system.

Please find below the array for the Female SubD 13w3 Connector:

| <i>Cable number/Color</i> | <i>Pin number</i> | <i>In / Out signal</i> | <i>Designation</i> | <i>Signal</i> |
|---------------------------|-------------------|------------------------|-------------------------|--|
| 1 | A1 | In | Power supply + | 24V DC |
| 2 | A3 | In | Common Ground | 0V |
| 3 | Pin 1 | In | Intensity Control - DIM | 0-10V direct |
| 5 | Pin 6 | Out | Temperature Default | 0V to 6V: Fault / 16V to 24V: No Fault |
| 6 | Pin 7 | Out | LED fault | 0V to 6V: Fault / 16V to 24V: No Fault |
| 7 | Pin 4 | In | Enable + | Dry contact CLOSED: UV emission allowed; OPEN: UV emission stopped |
| 8 | Pin 5 | In | Enable - | |
| Yellow and Green | | | Protective Ground | |