

# *SpectraTec II*

## Dual Laser Source

**BLUE SKY  
RESEARCH**

- **Two individual laser wavelengths**
- **One single mode PM fiber output**
- **Ultra-Stable, never needs re-alignment**
- **Compact: 125mm x 105mm x 34mm**
- **Integrated control and drive electronics**



The SpectraTec II, two wavelength laser module is a highly integrated fiber optic system comprised of two temperature controlled lasers with individual driving, control and stability electronics, and one single mode, polarization maintaining fiber optic pigtail output. Beam shaping of the output from the fiber and real time power feedback module (FFC – Fiber Feedback Collimator) are included.

There is an extensive range of electronic functionality available through the 25-pin interface connector. Complete control and interrogation of the module status is available to you. The Fiber Feedback Collimator (FFC) provides precision beam shaping or beam focusing, and real time power feedback to the control circuits. Power Stability of <0.5% under normal operating conditions is achieved using this technique.

This system leverages our extensive experience in precision fiber coupling of laser diodes providing the highest degree of fiber coupling stability. This results in systems that have near perfect laser beam co-linearity and beam stability enabling the design of instruments and systems with high stability and reliability.

Custom configurations are available and include; wavelength options ranging from 405 - 980nm, various power levels, OEM specific collimation or relay optics, multimode lasers and multimode fibers, and various cabling and fiber connector types. In addition, we can co-engineer custom interfaces (with your engineering team) to match your system control, GUI, monitoring and operational requirements.

### WAVELENGTHS

**405  
450  
473  
488  
520  
532  
638  
658  
705  
740  
785  
808  
830  
850  
905  
980**

# SpectraTec II

## Polarized Dual-Laser Source

### SpectraTec II Laser Wavelengths

The SpectraTec II provides a rugged, stable, laser-based illumination source which never needs re-alignment in your system or instrument. The single mode, polarization maintaining output fiber combines two lasers. Multimode Fiber outputs are available upon request. An example of a popular R + B laser system is 638nm + 488nm.

Optical Specifications	Popular Wavelengths								
Wavelengths*	nm	405	450	488	520	532	638	658	785
Laser Output Power (Max)	mW	25	25	25	25	25	50	50	40
Fiber output mode field dia	μm	3.0	4.0	3.5	3.5	3.5	4.2	4.2	4.5
FFC module output beam dia	mm	1.7	1.7	1.7	1.8	1.8	1.9	1.9	1.9
Divergence (Far Field)	mRad	0.45	0.45	0.45	0.4	0.4	0.35	0.35	0.35

\* A variety of single mode laser wavelengths and power levels are available for combining; some of the more common wavelengths include; 405, 450, 473, 488, 520, 532, 632, 638, 658, 785, 808, 830, 850, 905 and 980. For single mode operation the combined set of lasers must be between 405nm and 660nm or 660nm and 980nm. Custom OEM configurations are available.

### General Product Specifications: (PM fiber with FFC, fiber feedback collimator)

Optical Parameter	Units	Specification			Conditions* All Laser Wavelengths
		Min.	Typ.	Max	
Power stability (1 hours)	%			0.5	1 hrs, ΔT +/- 3°
Power stability (24 hours)	%			≤2.0	24 hrs
Power stability (ΔT)	%			2.5	1 hr, ΔT= 10° - 40°
Laser Noise, RMS	% RMS			<0.5	10Hz – 2MHz BW, at 50-100% power
Laser Noise Pk-Pk	%			1.25	10Hz – 2MHz BW, at 50-100% power
Polarization Ratio	dB	20	25		Vertical
Beam Aspect Ratio		0.9	1.0	1.1	Over beam path, 1/e2
Pointing Angle	mRad		1	3	
Beam Co-alignment	%			100	At exit aperture
Laser Beam Diameter	mm	1.6	1.7	2.1	Exit - 20cm from collimator, 1/e2 value
Laser Beam Divergence**	mrاد	0.3	0.45	0.55	Far Field
Laser Shutdown Time	μs		20	50	
M2				1.1	Calculated, Far Field, any channel
X-Talk	%		1	3	Target laser power @ 50-100% Other laser switched on/off @ 100% power
RoHS Compliant		Yes			All parts, assemblies and packaging
CDRH Classification		IIIb			Laser dependent
ESD Rating		Level 3			

\* all data at constant temperature unless specified otherwise

\*\* Wavelength dependent

Contact Information:

Blue Sky Research \* 510 Alder Drive \* Milpitas, CA 95035 \* (408)941-6068  
[www.blueskyresearch.com](http://www.blueskyresearch.com)\* email: [Sales@blueskyresearch.com](mailto:Sales@blueskyresearch.com)

# ***SpectraTec II***

## ***Polarized Dual-Laser Source***

### **Absolute Maximum Ratings**

Parameter	Units	Specifications		Conditions
		Min	Max	
Operating Temperature	°C	10	40	Non-Condensing
Storage Temperature	°C	-10	75	
Storage Humidity	%	10	90	Non-Condensing

### **General Electrical Specifications:**

Electrical Specifications	Units	Specifications	
Operating Voltage*	V	5V ± 0.5, 8V ± 0.5	
Operating Current	A	3A max with both lasers at full power	
		High-Speed modulation ACC mode **	Standard modulation lasers APC or ACC mode **
Analog Modulation Freq		1MHz	10KHz
Rise Time	nS	250	1000
Fall Time	nS	100	500
Dynamic Extinction Ratio	dB	>25	>25

\* Typical Vcc requirements are 5V, some LD can require an additional 8V Vcc

\*\* ACC is automatic current control, APC is automatic power control

### **General Mechanical Specifications**

Mechanical Parameter	Units	Specification	Comments
SpecTec II Housing		Aluminum	
SpecTec II Dimensions	mm	125 x 105 x 34	L x W x H, see drawing for details
Collimator Housing		Aluminum	
Collimator Dimensions	mm	105 x 40 x 26	L x W x H, see drawing for details
Static beam location (V)	mm	9	referenced to collimator base
Static beam location (H)	mm	27.5	referenced to mounting hole center
Fiber Type			Varies by wavelength plan
Output Fiber Cable		3mm buffer or armored	50 – 100cm lengths available
Interface connector		25 pin D-Sub	On SpectraTec II housing

Contact Information:

**Blue Sky Research** \* 510 Alder Drive \* Milpitas, CA 95035 \* (408)941-6068

[www.blueskyresearch.com](http://www.blueskyresearch.com)\* email: [Sales@blueskyresearch.com](mailto:Sales@blueskyresearch.com)

# ***SpectraTec II***

## ***Polarized Dual-Laser Source***

### **Electrical Interface**

<b>25-pin D-sub Connector</b>	<b>Name</b>	<b>Direction</b>	<b>Comment</b>
J2-1	Laser 1 PM	Analog Output	Laser 1 LD Monitor
J2-2	GND		GND
J2-3	Laser 2 PM	Analog Output	Laser 2 PD Monitor
J2-4	GND		GND
J2-5	Reserved	NC	NC
J2-6	GND	Power Input	GND
J2-7	Laser 1 Power Adjust	Analog Input	Vset for Laser 1
J2-8	Laser 1 Enable	Digital Input	Active HI
J2-9	Laser 2 Power Adjust	Analog Input	Vset for Laser 2
J2-10	Status of TECs OK	Digital Output	HI if both TECs within range
J2-11	Laser 2 LD Signal	Analog Output	Laser 2 LD Current Monitor
J2-12	Laser 1 LD Signal	Analog Output	Laser 1 LD Current Monitor
J2-13	Reserved	NC	NC
J2-14	GND		GND
J2-15	+5V	Power Input	Power
J2-16	GND		GND
J2-17	+5V	Power Input	Power
J2-18	GND		GND for Power
J2-19	+5V	Power input	Power
J2-20	GND		GND for Power
J2-21	Laser 1 Enable	Digital Input	Active HI
J2-22	GND		GND for Power
J2-23	+8V or NC	Power input	8V Vcc Power if needed
J2-24	GND		GND for Power
J2-25	Vcc OK	Digital output	HI if 5V supply within range

The SpectraTec II module has a 25 pin D-sub male connector. The Module is provided with a 50cm cable terminated in a 25 D-Sub female connector on both ends providing pin the pin functions outlined in the table above.

Contact Information:

**Blue Sky Research** \* 510 Alder Drive \* Milpitas, CA 95035 \* (408)941-6068  
[www.blueskyresearch.com](http://www.blueskyresearch.com)\* email: [Sales@blueskyresearch.com](mailto:Sales@blueskyresearch.com)

**SpectraTec II** Rev 12/21/16

# SpectraTec II

## Polarized Dual-Laser Source

### Mechanical Drawing

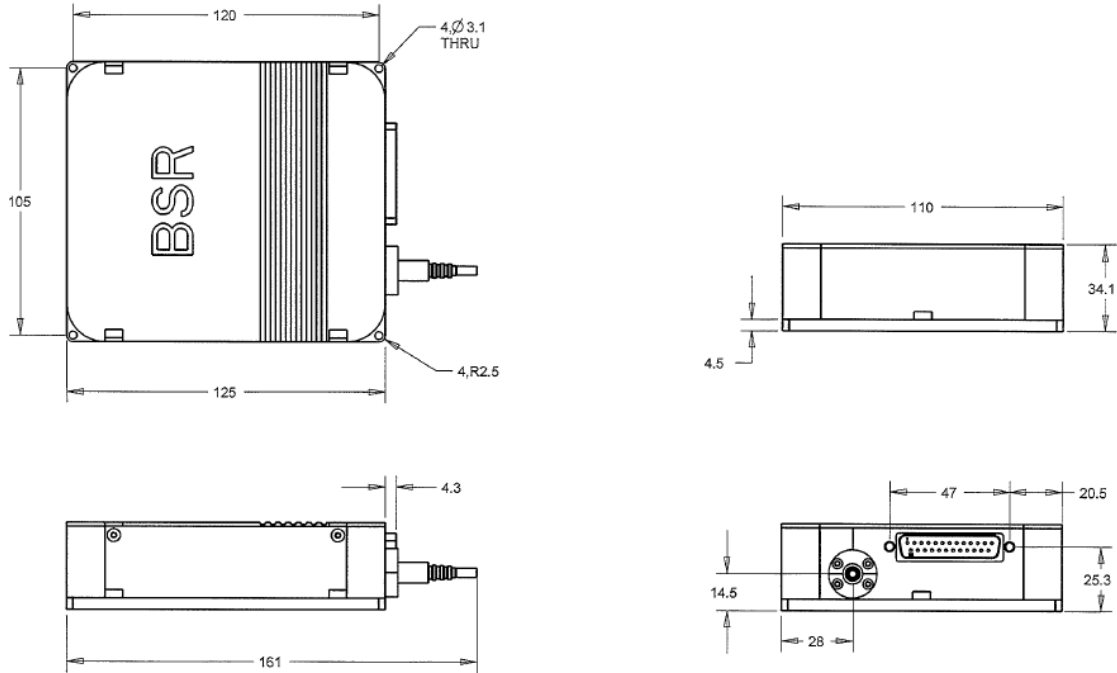

### FFC Housing

Simple collimator housings without feedback systems are available

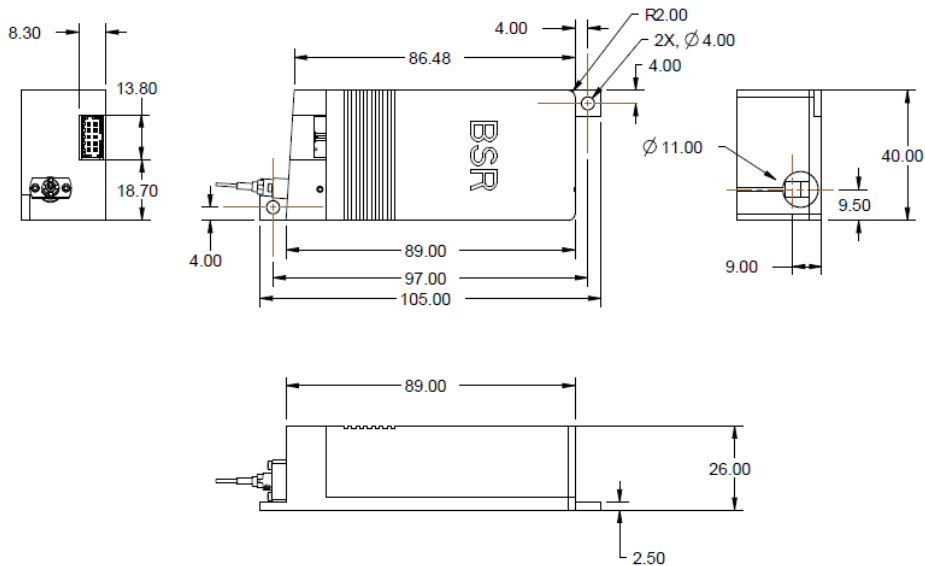

Contact Information:

**Blue Sky Research** \* 510 Alder Drive \* Milpitas, CA 95035 \* (408)941-6068  
[www.blueskyresearch.com](http://www.blueskyresearch.com)\* email: [Sales@blueskyresearch.com](mailto:Sales@blueskyresearch.com)

SpectraTec II Rev 12/21/16

# ***SpectraTec II***

***Polarized Dual-Laser Source***

**Our Sales or Applications Engineers will be happy to help you determine the best product choice to meet your requirements and provide you with detailed performance specifications on individual lasers. They can also assist you with options, system specifications or device customization your system may need.**

**Please contact Blue Sky Research, (408) 941- 6068, or visit our Website;  
[www.BlueSkyResearch.com](http://www.BlueSkyResearch.com) or email us at [sales@blueskyresearch.com](mailto:sales@blueskyresearch.com)**

**Blue Sky Research is an ISO 9001:2008 certified company**

This component does not comply with the Federal Regulations (21 CFR Subchapter1) as administered by the Center for Devices and Radiological Health. Purchaser acknowledges that his/her products must comply with these regulations before they can be sold to a customer. The output light from laser diodes is harmful to a human body even if it is invisible. Avoid looking at the output light of a laser directly or even indirectly through a lens during operation. Observance of operation should be through a TV camera or related equipment. Refer to IEC 60825-1, IEC 60601-2-22:2007 and 21 CFR 1040.10-1040.11 as a radiation safety standard for laser products.

Blue Sky Research follows a policy of continuous improvement. Specifications are subject to change without notice.



[info@amstechnologies.com](mailto:info@amstechnologies.com)  
[www.amstechnologies-webshop.com](http://www.amstechnologies-webshop.com)

