

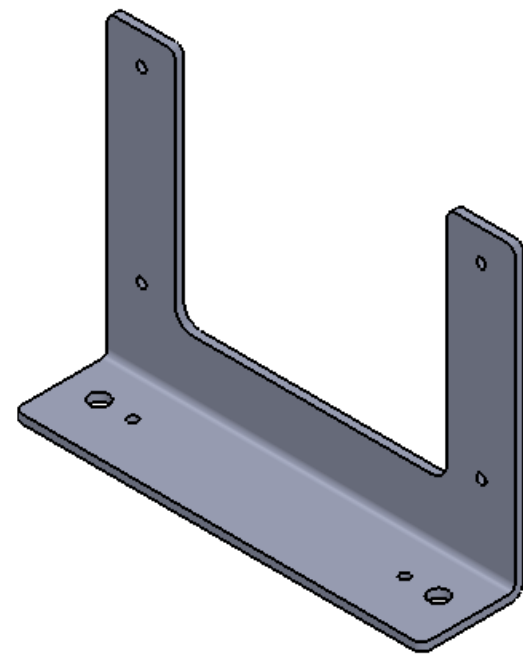

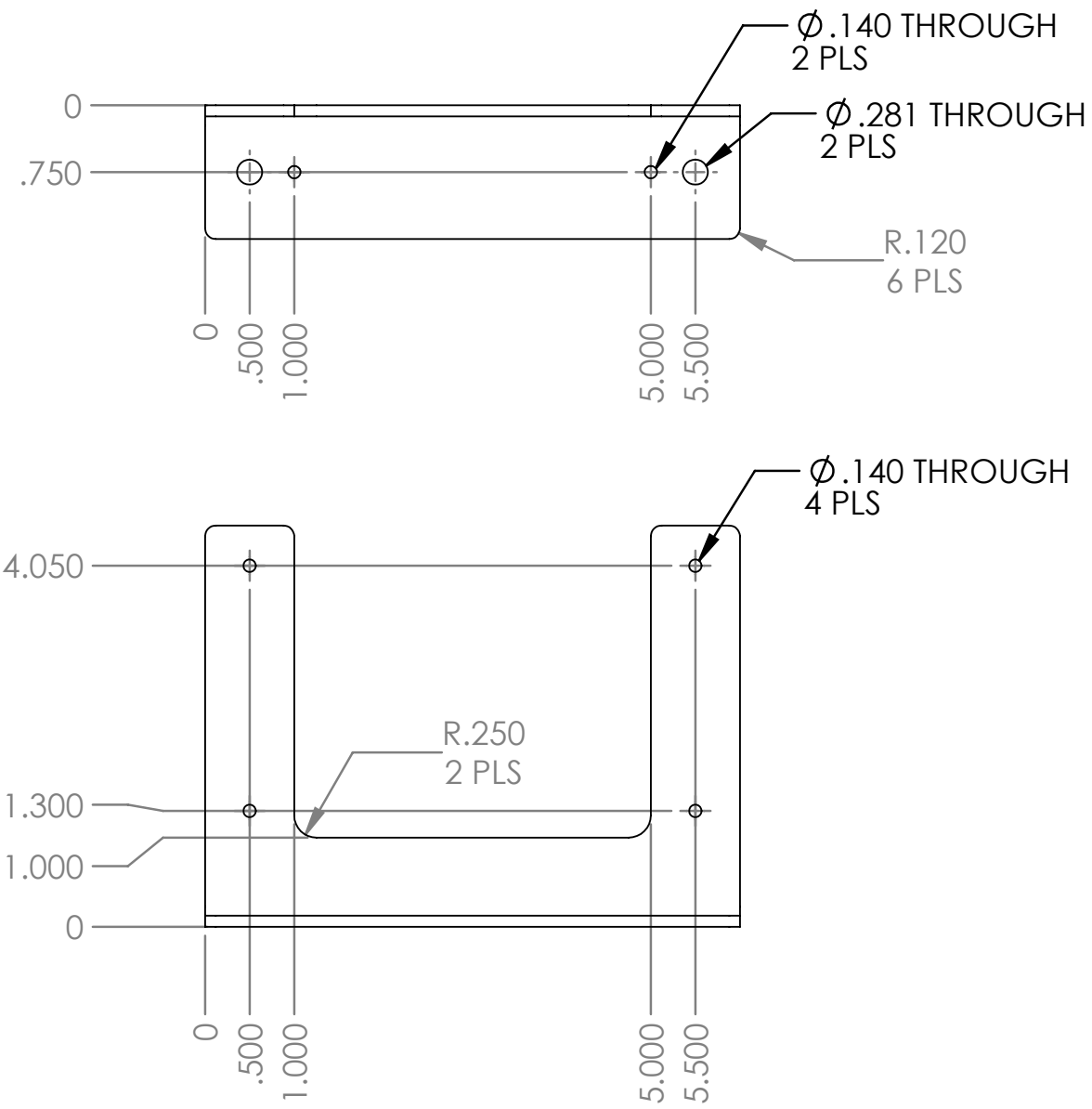

REVISIONS			
REV.	DESCRIPTION	DATE	APPROVED
A	INTRODUCE TO PRR	2-21-12	GSN



- NOTES:** (UNLESS OTHERWISE SPECIFIED)
1. MATERIAL: MAKE FROM 1/8" (.125) THICK 5052-H32 ALUMINUM ALLOY.
 2. BREAK SHARP EDGES AND REMOVE ALL BURRS.
 3. DIMENSIONS APPLY AFTER PLATING.
 4. BLACK ANODIZE PER MIL-A-8625, TYPE II, CLASS 2.
 5. SURFACE SHALL EXHIBIT NO DEFECTS SUCH AS SCRATCHES, DINGS, MARKS, ETC.
 6. PACKAGING: PARTS TO BE INDIVIDUALLY PACKAGED TO AVOID DAMAGE DURING SHIPMENT.
 7. INSPECTION: VERIFY OVERALL DIMENSIONS. VERIFY SIZE AND PLACEMENT OF HOLES. VERIFY ANODIZE FINISH IS CONSISTANT.

UNLESS OTHERWISE SPECIFIED DIMENSIONS ARE IN INCHES		THIS DRAWING AND INFORMATION CONTAINED THEREIN ARE THE PROPERTY OF WAVELENGTH ELECTRONICS, INC. (WEI). BY ACCEPTING THIS INFORMATION, THE BORROWER AGREES THAT IT WILL NOT BE USED FOR ANY PURPOSE OTHER THAN FOR WHICH IT WAS LOANED. IF THE BORROWER OF THIS DOCUMENT HAS NOT SIGNED A CONFIDENTIALITY AGREEMENT WITH WEI, THEN HE/SHE MUST REPORT THIS FACT TO WEI.																			
TOLERANCES 1 PL DECIMALS $\pm .1$ 2 PL DECIMALS $\pm .01$ 3 PL DECIMALS $\pm .005$ ANGLES $\pm 1^\circ$ FRACTIONS $\pm 1/64$ TH		APPROVALS <table border="1"> <tr> <th colspan="2">SIGNATURES</th> <th>DATE</th> </tr> <tr> <td>ORIGINATOR</td> <td>G. NIEBEL</td> <td>2-21-12</td> </tr> <tr> <td>ENGINEERING</td> <td></td> <td></td> </tr> <tr> <td>CHECKED</td> <td></td> <td></td> </tr> <tr> <td>APPROVED</td> <td></td> <td></td> </tr> <tr> <td>APPROVED</td> <td></td> <td></td> </tr> </table>		SIGNATURES		DATE	ORIGINATOR	G. NIEBEL	2-21-12	ENGINEERING			CHECKED			APPROVED			APPROVED		
SIGNATURES		DATE																			
ORIGINATOR	G. NIEBEL	2-21-12																			
ENGINEERING																					
CHECKED																					
APPROVED																					
APPROVED																					
THIRD ANGLE PROJECTION																					
		 Phone: (406) 587-4183 Fax: (406)-587-4911 51 Evergreen Dr. Suite B Bozeman, MT. 59715																			
		TITLE: HEATSINK BRACKET																			
		SIZE B	DWG (PRR) NO.: HTSK-BRKT-500-A																		
		SCALE: 1:1	REV A																		
		SHEET 1 OF 1																			