

DATASHEET AND OPERATING GUIDE

WTCP5V5A

5 A PWM Temperature Controller

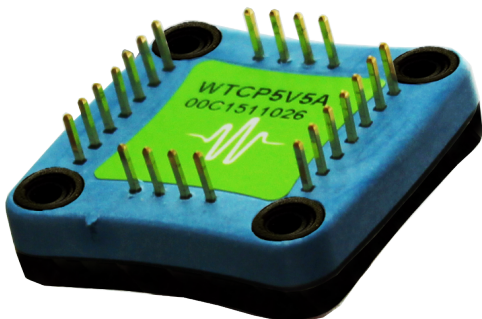

COMPACT, POWERFUL, EFFICIENT

The WTCP5V5A PWM Temperature Controller delivers all the advantages of Pulse Width Modulated (PWM) control in a compact PCB-mounted package.

High efficiency, low power dissipation, high stability, and high accuracy are the hallmarks of the WTCP design. The WTCP is perfect for electro-optical systems, airborne instrumentation, medical diagnostic equipment, and other applications where compact size and high efficiency are critical.

VALUABLE SAFETY FEATURES

Built-in safety features such as current limit and voltage limit make the WTCP robust to real-world operating conditions. Long-term reliability means better up-time, fewer service calls, and more satisfied and successful customers.

FEATURES AND BENEFITS

- Drive up to ± 5.0 A of TEC current
- High efficiency Pulse Width Modulated controller
- Single 5 VDC supply operation
- Separate electronics and load power supplies can be used when lower noise is required
- Small package: 1.3" x 1.28" x 0.31"
- Short term stability: 0.001°C
- Long term stability: 0.002°C
- Adjustable current and voltage limits
- Comprehensive and easy-to-use evaluation board

DESIGNED FOR EASY INTEGRATION

The WTCP5V5A can operate from a single 5 V power supply, or the WTCP and load can be driven from separate power supplies for even lower output current noise.

The available WTCPEVAL evaluation circuit board includes everything needed to quickly configure the WTCP for a wide range of applications and load conditions. The onboard feedback loop adjustment switches simplify tuning, and dramatically reduce your development time.

Few passive external components are required to operate the WTCP. And thanks to the high efficiency output stage, the WTCP does not normally require additional heatsinking.

The WTCPOEM board condenses the adjustable functions of the WTCPEVAL board into a compact bare board, perfect for system integration. Install your own components, or we will customize with a Product Variation.

CONTENTS	PAGE
QUICK CONNECT GUIDE	2
PIN DESCRIPTIONS	4
ELECTRICAL SPECIFICATIONS	5
SAFETY INFORMATION	6
OPERATING THE WTCP5V5A	7
CALCULATE COMPONENT AND VOLTAGE VALUES	8
CONFIGURE THE WTCP5V5A EVALUATION BOARD	12
TUNING THE WTCP5V5A	16
MECHANICAL SPECIFICATIONS – WTCPOEM	22
MECHANICAL SPECIFICATIONS – WTCPEVAL	23
MECHANICAL SPECIFICATIONS – WTCP5V5A	24
CERTIFICATION AND WARRANTY	25

ORDERING INFORMATION

PART NO	DESCRIPTION
WTCP5V5A	± 5 A PWM Temperature Controller
WTCPEVAL	Evaluation board for WTCP5V5A
WTCPOEM	Bare OEM PCB for WTCP5V5A
WEV300	Thermal Management Kit -- Thermal Washer and Heatsink
WEV301	Thermal Management Kit -- Washer, Heatsink and +5 V Fan
WEV302	Thermal Management Kit -- Washer, Heatsink and +12 V Fan



QUICK CONNECT GUIDE



TO ENSURE SAFE OPERATION OF THE WTCP CONTROLLER, IT IS IMPERATIVE THAT YOU DETERMINE THAT THE UNIT WILL BE OPERATING WITHIN THE SAFE CASE OPERATING TEMPERATURE RANGE.

Refer to **page 18** to determine if a case heatsink is required for safe and reliable operation of the WTCP.

If you have any questions about the Safe Case Operating Temperature, call the factory for free and prompt technical assistance.

Figure 1 shows the package pin-out from the top view.

Figure 2 is the basic schematic required to implement the WTCP. Fixed-value resistors are shown.

The heating- and cooling-current limits are 5 amps in this circuit. Instructions for setting the current and voltage limits are found on **page 9**.

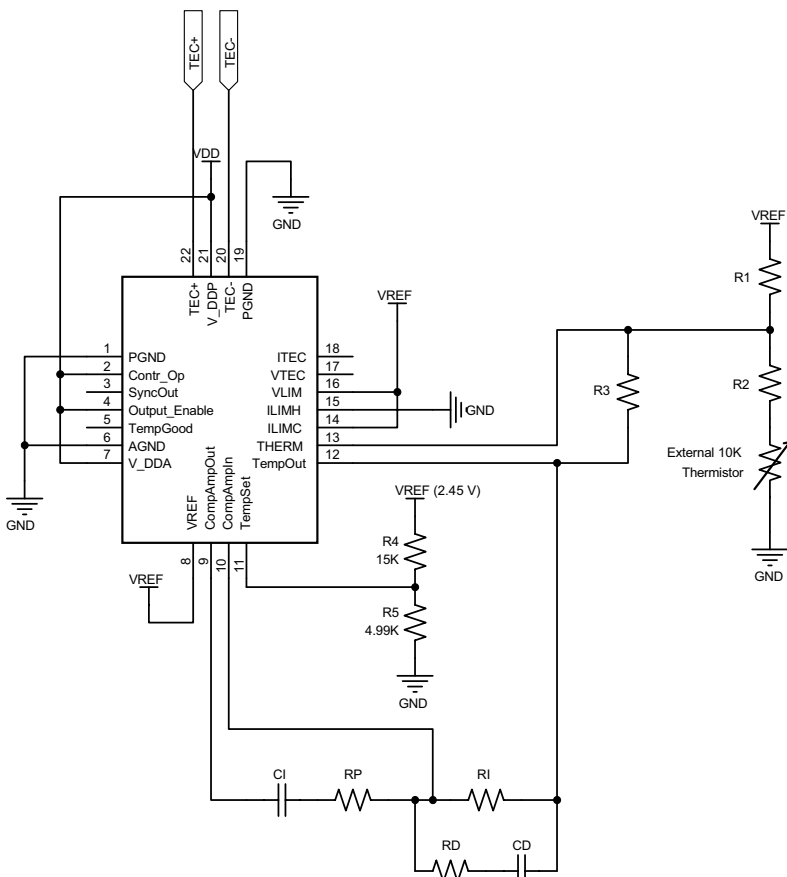

Figure 2. Basic WTCP Implementation

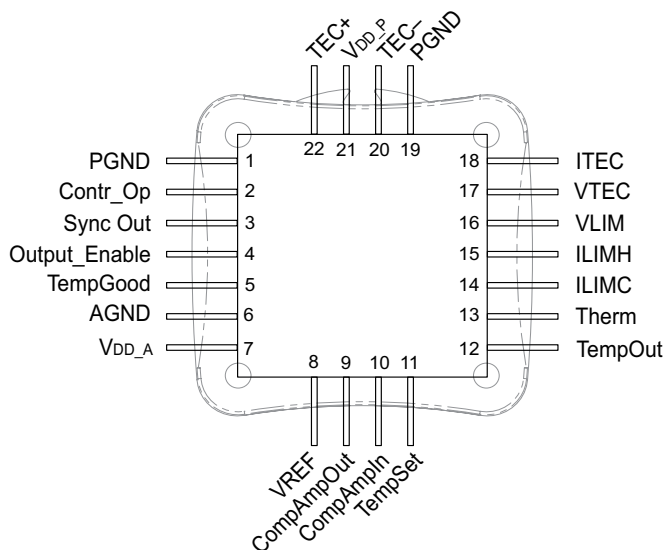

Figure 1. WTCP Pinout - Top View

Table 1 lists the external component values for an operating range of 20°C to 40°C and a 25°C setpoint. Equations for calculating different temperature ranges and setpoints start on **page 10**.

Table 1 also includes recommended start values for the feedback loop components. Instructions for tuning the feedback loop for other thermal loads are provided on **page 16**.

Table 1. External Component Values for 25°C Setpoint

COMPONENT	VALUE
R_{TH} (Thermistor)	10 kΩ at 25°C
R1	14.2 kΩ
R2	6.15 kΩ
R3	59.7 kΩ
RP	1.24 MΩ
RI	1 MΩ
RD	150 kΩ
CI	0.47 μF
CD	1.0 μF

We recommend using a test load until you are familiar with operating the WTCP. **Figure 3** illustrates a simple test load.

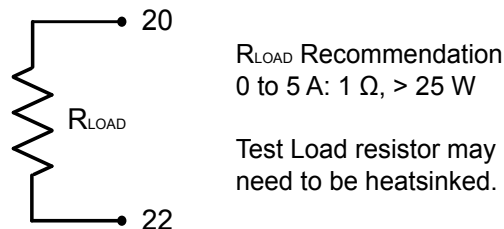

Figure 3. Test Load

Figure 4 shows the WTCPEVAL board and identifies the main operating sections. The evaluation board must be properly configured before it can be used with the WTCP controller; refer to the instructions beginning on page 12.

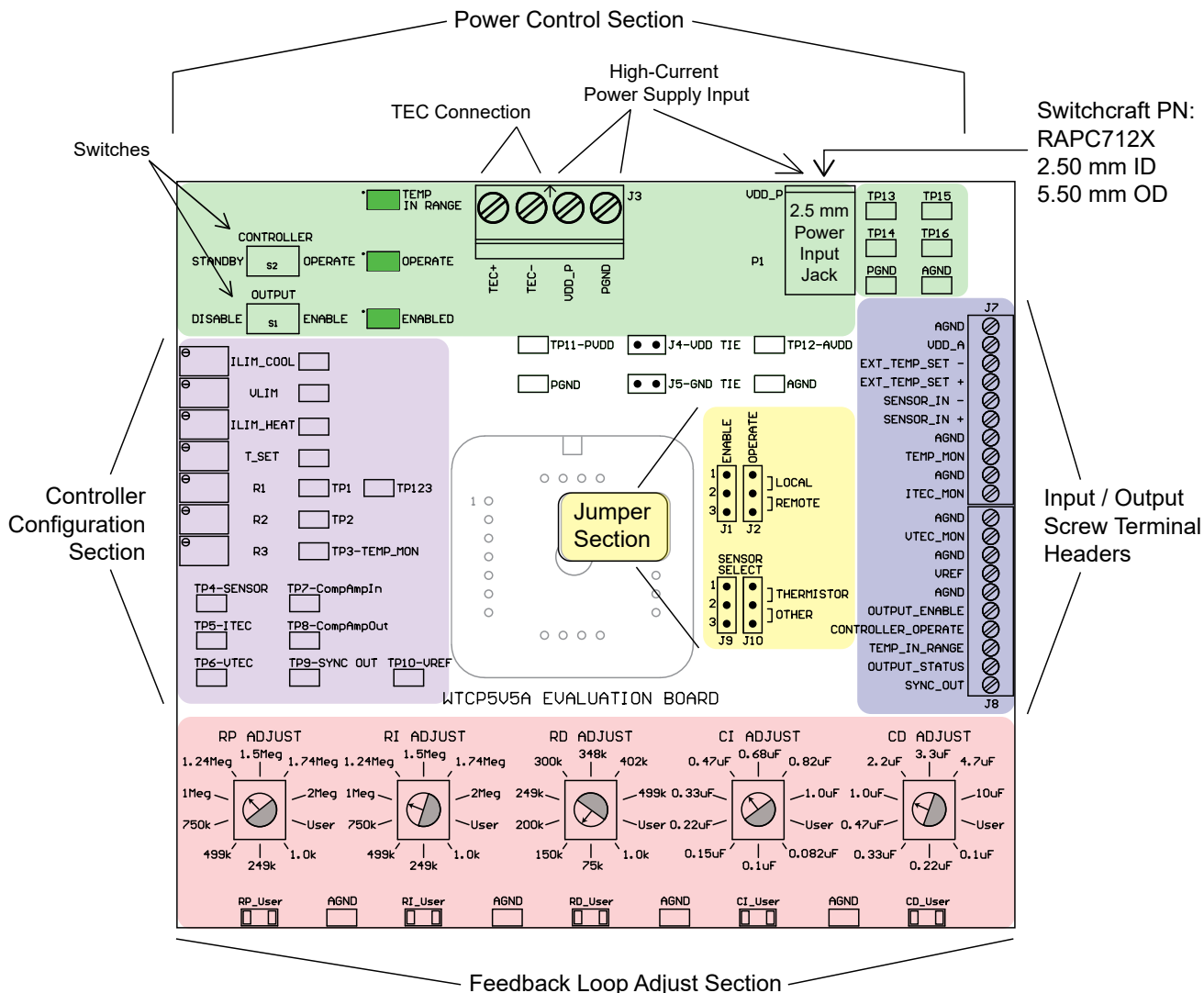

Figure 4. WTCPEval Board Top View

To measure key settings, unplug the evaluation board from power, then unplug the thermoelectric from the evaluation board. Table 2 shows where to connect a multimeter and what to measure.

Table 2. Measurement Test Points

SETTING	MULTIMETER PLACEMENT		MEASURE
	+	-	
I _{LIM} COOL	ILIM_COOL	AGND	VOLTAGE
V _{LIM}	VLIM		
I _{LIM} HEAT	ILIM_HEAT		
SET T	T_SET	TP123	RESISTANCE
R1	TP1		
R2	TP2		
R3	TP3		

PIN DESCRIPTIONS

Table 3. WTCP Pin Descriptions

WTCP		EVALUATION BOARD		PIN DESCRIPTION
PIN	PIN NAME	CONNECTOR AND PIN	NAME	
1	PGND	P1-Outer; J3-1	PGND	Ground for high current power supply.
2	Contr_Op	J8-7	CONTROLLER_OPERATE	Place the controller in Operate or Standby mode. TTL-compatible. Operate = Float or High. Standby = Ground. Pin will sink up to 5 mA. Refer to page 13 for details on Standby mode operation.
3	SyncOut	J8-10	SYNC_OUT	PWM Clock signal. Pin will source up to 5 mA, and can be used to synchronize multiple WTCP controllers.
4	Output_Enable	J8-6	OUTPUT_ENABLE	Enable or disable the TEC controller drive current. TTL-compatible. Enable = Float or High. Disable = Ground. Pin will sink up to 5 mA. Refer to page 13 for details on Output control.
5	TempGood	J8-8	TEMP_IN_RANGE	High signal indicates when sensor voltage is within ± 100 mV of TempSet voltage. Pin will source up to 5 mA.
6	AGND	J7-1, -7, -9 J8-1, -3, -5,	AGND	Low-current ground connection for controller electronics. Do not use this ground connection for the TEC.
7	V _{DD_A}	J7-2	VDD_A	Supply voltage for controller electronics. Connect the negative terminal of the V _{DD_A} power supply to AGND.
8	V _{REF}	J8-4	VREF	2.45 V (nominal) reference voltage output. Pin will source up to 2 mA. For best results, measure the actual value of V _{REF} .
9	CompAmpOut	–	–	Connection for the components used to tune the PID control loop parameters. Refer to page 16 for details.
10	CompAmpIn	–	–	Connection for the components used to tune the PID control loop parameters. Refer to page 16 for details.
11	TempSet	J7-4	EXT_TEMP_SET+	Positive signal connection for external temperature setpoint signal. Refer to Eq. 14 . The negative connection on the evaluation board for the external temperature setpoint signal is EXT_TEMP_SET– (pin J7-3) or AGND.
12	TempOut	J7-8	TEMP_MON	Output signal that represents the actual temperature measured by the sensor. Refer to Eq. 12 .
13	Therm	J7-6	SENSOR_IN+	Temperature sensor connection. When using the evaluation board connect the other lead of the thermistor to pin J7-5 or AGND.
14	ILIMC	–	–	Voltage input to set the Cooling-direction output current limit.
15	ILIMH	–	–	Voltage input to set the Heating-direction output current limit.
16	VLIM	–	–	Voltage signal input to set the output voltage limit.
17	VTEC	J8-2	VTEC_MON	Analog output providing a signal equal to voltage across the TEC+ and TEC– pins. See Eq. 15 and Eq. 16 .
18	ITEC	J7-10	ITEC_MON	Analog output providing a signal proportional to the current being driven to the TEC. See Eq. 17 .
19	PGND	P1-Outer; J3-1	PGND	Ground for high current power supply.
20	TEC–	J3-3	TEC–	Negative side of TEC. This pin sinks current from the TEC.
21	V _{DD_P}	P1-Inner; J3-2	VDD_P	High-current supply input to drive the TEC. Connect the negative terminal of the V _{DD_P} power supply to PGND.
22	TEC+	J3-4	TEC+	Positive side of TEC. This pin sources current to the TEC.

ELECTRICAL SPECIFICATIONS

PARAMETER	SYMBOL	MAX	UNIT	NOTE
ABSOLUTE MAXIMUM RATINGS				
Power Supply Voltage, Load Power Supply ¹	V_{DD_P}	5.5	VDC	
Power Supply Voltage, Chip Power Supply ¹	V_{DD_A}	5.5	VDC	
Maximum Output Power	P_{MAX}	22.5	W	
Efficiency		85 to 95	%	Depending on Load Impedance
Case Operating Temperature	T_{OPR}	-40 to 85	°C	
Maximum Safe Case Operating Temperature	T_{SCOT}	85	°C	See page 18 .
Case Storage Temperature	T_{STG}	-40 to 125	°C	
Weight		0.6	oz	17 g
Size		1.28 x 1.3 x 0.31	inches	32.5 x 33.0 x 7.9 mm
Pin Solderability Time ²		5	sec	Solder temperature 390°C

PARAMETER	SYMBOL	MIN	TYP	MAX	UNIT	NOTE
OUTPUT CURRENT						
Max Output Current	I_{MAX}		4.5		A	$V_{DD_P} = 5\text{ V}$
Max Output Current	I_{MAX}		5.0		A	$V_{DD_P} = 5.5\text{ V}, 0.9\ \Omega$ Load
Minimum Compliance Voltage	V_{COMP}		$V_{DD_P} - 0.35$		V	$V_{DD_P} = 5.0\text{ V}, 1\ \Omega$ Load
Short Term Stability, 1 hr			< 0.001		°C	Using 10 kΩ thermistor
Long Term Stability, 24 hr			< 0.002		°C	Using 10 kΩ thermistor
Temperature Coefficient			< 200		ppm / °C	

POWER SUPPLY						
Load Power Supply, high current ¹	V_{DD_P}	4.5	5.0	5.5	VDC	
Electronics Power Supply, low current ¹	V_{DD_A}	4.5	5.0	5.5	VDC	Must source > 15 mA
Quiescent Current, V_{DD_P}			3		mA	Output Disabled, WTCP in Standby mode
Minimum Current Rating, V_{DD_P}			$1.1 \times I_{OUT}$		A	

TEMPERATURE SENSOR						
Sensor Compatibility		Thermistor				
Resistance Range of Setpoint		2		200	kΩ	WTCP absolute maximum
		2		50	kΩ	WTCP for best stability
		2		17	kΩ	with WTCPEVAL ³

SETPOINT, LIMIT INPUTS						
Cooling Current Limit Voltage Range	V_{ILIMC}	$V_{REF} / 2$		V_{REF}	V	See Note 4
Heating Current Limit Voltage Range	V_{ILIMH}	0.1		$V_{REF} / 2$	V	See Note 4
Heating / Cooling Voltage Limit	V_{LIM}	0		V_{DD_A}		
External Setpoint Input Range	$V_{TempSet}$	0 to V_{REF}			V	See Note 4
External Setpoint Damage Threshold		$(V_{TempSet} < 0)$ or $(V_{TempSet} > V_{REF})$			V	See Note 4

OUTPUTS						
TempGood, Logic Signal	$V_{TempGood}$	LOW = 0.2; Temp is Out of Range HIGH = $(V_{DD_A} - 0.2)$; Temp is In Range			V	
Reference Voltage ⁴	V_{REF}	2.35		2.56	V	$V_{REF} = 2.45\text{ V}$ Nominal

1. Separate power supplies can be used for V_{DD_P} and V_{DD_A} to reduce electrical noise on the thermal load.
2. Not compatible with aqueous cleaning processes.
3. Range can be extended to match WTCP. Contact factory for details.
4. When configuring the WTCP in your application, the best results will be achieved by measuring the actual value of V_{REF} .

SAFETY INFORMATION

SAFE CASE OPERATING TEMPERATURE

Before attempting to operate the WTCP controller, it is imperative that you first determine that the unit will operate below the maximum *Safe Case Operating Temperature* (SCOT). Operating outside of the SCOT may damage the controller or the load. Operating outside of the SCOT will void the warranty.

Refer to **page 18** to determine if a case heatsink and/or fan is required for safe and reliable operation of the WTCP.



TO ENSURE SAFE OPERATION OF THE WTCP CONTROLLER, IT IS IMPERATIVE THAT YOU DETERMINE THAT THE UNIT WILL BE OPERATING WITHIN THE SAFE CASE OPERATING TEMPERATURE RANGE.

If you have any questions about the Safe Case Operating Temperature, call the factory for free and prompt technical assistance.

THEORY OF OPERATION

The WTCP Series Temperature Controllers feature pulse-width modulated output for high current, high efficiency, and compact package size.

Pulse-width modulated controllers are more efficient and smaller than their linear-mode counterparts. Thanks to high-efficiency switching transistors, the WTCP dissipates very little heat internally and in most applications no additional heatsinking is required for the WTCP to operate safely. Heatsinking may be required when operating in elevated ambient temperatures.

The load temperature is measured with a thermistor. The WTCP places the thermistor in a resistor network that maximizes sensing sensitivity by linearizing the resistance response over the design control range.

The WTCP compares the sensor voltage to the setpoint voltage, and adjusts the output to effect a change in load temperature and reduce the difference in the two voltages. Once the sensor voltage reaches the setpoint temperature, the controller continues adjusting the output to keep the voltage difference minimized.

The WTCP drives the thermal load—a thermoelectric—with a pulse-width modulated current. If more current is needed to keep the load cool the controller increases the modulation ON-time and decreases the OFF-time. To switch from heating-mode to cooling-mode, the controller reverses the direction of current flow through the TEC.

The WTCP5V5A Evaluation Board contains all the external components necessary to evaluate and configure the controller. Once operation is understood with the evaluation board, the WTCP can be seamlessly transferred to an OEM circuit board. The WTCPEVAL board is optimized for 10 k Ω thermistors. Setpoint range is between 2 and 17 k Ω .* The WTCP itself can support a setpoint range of 2 to 50 k Ω with excellent stability. Setpoints ranging from 50 to 200 k Ω are supported by the WTCP, but with decreasing stability.

The controller and evaluation boards include features that help protect the load from damage, and also make it more versatile in a wide array of applications.

- Current and voltage limit are set by the user in order to prevent over-driving and damaging the TEC.
- Adjustable temperature control range maximizes controller accuracy and stability.
- TempGood signal indicates when the sensor voltage is within ± 100 mV of the setpoint voltage.

* Range can be extended to match the WTCP. Contact factory for details.

OPERATING THE WTCP5V5A

The first step is to **Calculate Component and Voltage Values on page 8**. This step is necessary whether the WTCP is used on the evaluation board or in a custom circuit application.

The next step is to **Configure the WTCP5V5A EVALUATION Board on page 12**. The instructions are written specifically for using the WTCPEVAL board, but apply in cases where the WTCP is used on a custom PCB, as well.

Finally, instructions are provided **“Tuning the WTCP5V5A” on page 16** for operating the WTCP on the evaluation board. This section includes information on setting the temperature setpoint and tuning the PID control loop.

NECESSARY EQUIPMENT

- WTCP Temperature Controller
- WTCPEVAL Board (recommended)
- Digital multimeter (DMM), 4-½ digit resolution recommended
- Power supplies:
 - V_{DD_P} rated for 1.1-times the maximum TEC current
 - V_{DD_A} rated >15 mA, to power the WTCP5V5A
- Thermistor
- Peltier-type thermoelectric module
- Heatsink, mounting hardware, thermal washers or thermal paste
- Connecting wires

PREVENT DAMAGE FROM ELECTROSTATIC DISCHARGE

Before proceeding, it is critical that you take precautions to prevent electrostatic discharge (ESD) damage to the controller and your load. ESD damage can result from improper handling of sensitive electronics, and is easily preventable with simple precautions.

Enter the search phrase “ESD Precautions for Handling Electronics” in an internet search engine to find information on ESD-safe handling practices.

We recommend that you always observe ESD precautions when handling the WTCP controller and your thermal load.

OPERATING THE WTCP WITH THE EVALUATION BOARD

The WTCPEVAL board is designed to give full access to the features and functions of the WTCP module, making it easier to integrate the WTCP into OEM applications. The instructions provided here assume the WTCPEVAL board is being used, but the same principles apply when the WTCP is used on a custom circuit board.

Test points are provided on the evaluation board so that essential signals can be monitored during the configuration process. All identically-named testpoints (such as PVDD, PGND, etc) are electrically tied.

MEASURING RESISTANCE OF THE EVALUATION BOARD TRIMPOTS

When a resistance measurement is called for, such as setting the TEC voltage limits, power to the evaluation board must be switched off and disconnected. If resistance measurements are made with power applied, faulty readings will result and the configuration effort will not be successful.

SYMBOLOLOGY AND TERMINOLOGY

Throughout this datasheet certain symbols are used in the schematic drawings.

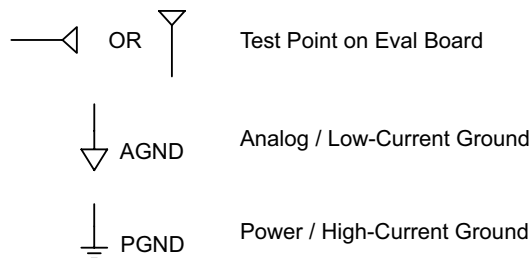

Figure 5. Schematic Symbols

CALCULATE COMPONENT AND VOLTAGE VALUES

Operating the WTCP5V5A requires external discrete components and input voltage signals. The first step to operate the WTCP is to calculate the component and voltage values.

If you wish to calculate the values manually, the procedure to select the component values is described beginning on [page 9](#).

INSTRUCTIONS FOR DOWNLOADED PROGRAM

A configuration program can be downloaded from the Wavelength website at this address:

<https://www.teamwavelength.com/support/design-tools/>

Figure 6 and **Figure 7** show the interface for the downloaded program.

Figure 6 shows the base configuration screen. First, enter your thermistor’s Steinhart-Hart coefficients. If you don’t know the coefficients, but know three data pairs -- resistance at a given temperature -- then select the Sensor Configuration tab (**Figure 7**). Follow the onscreen instructions to calculate the Steinhart-Hart coefficients and transfer the values back to the Configuration tab.

In the Operating Parameters section, input the upper and lower temperature limits. This should be a narrow band around your setpoint. The range does not need to include ambient temperature. Find the TEC current and voltage limits from the TEC manufacturer’s datasheet and enter them. Enter your system setpoint temperature.

Press the Calculate button. The evaluation board trimpot values and WTCP configuration input voltages are displayed in the lower part of the window.

The configuration results can be saved by selecting Save from the File menu at the top of the screen.

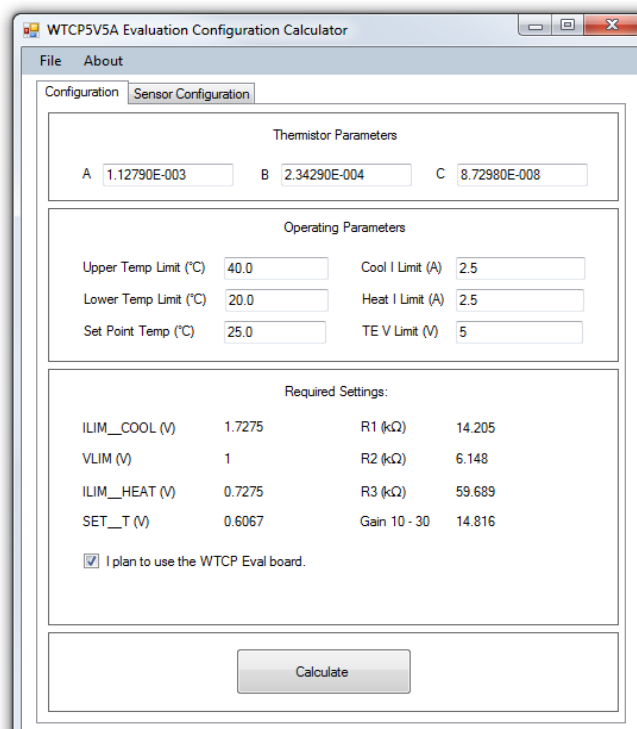

Figure 6. Configuration Calculator with Sensor Values

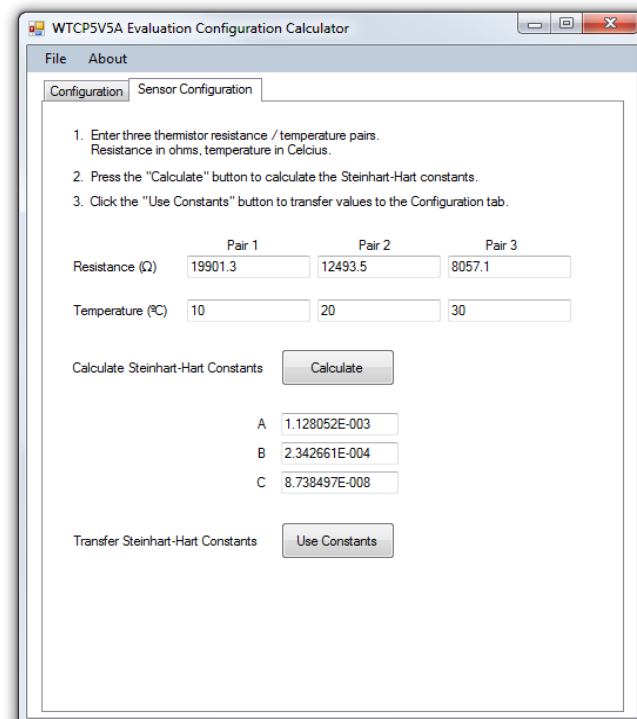

Figure 7. Sensor Configuration Tab

MANUALLY CALCULATE EXTERNAL COMPONENT AND VOLTAGE VALUES

These instructions help explain the operation of the WTCP controller. Write the component values into **Table 4** as you work through the equations.

Table 4. Calculated Setup Values

PARAM	VALUE	DESCRIPTION	SOURCE
V_{LIM}		TEC Voltage Limit	TEC Datasheet
V_{VLIM}		Voltage Limit Signal	Eq. 1, Eq. 2
I_{MAX_C}		Max Cooling Current	TEC Datasheet
V_{ILIMC}		Cooling I Lim Signal	Eq. 3
I_{MAX_H}		Max Heating Current	TEC Datasheet
V_{ILIMH}		Heating I Lim Signal	Eq. 4
R_L		Sensor Resistance at Bottom of Range	Thermistor Datasheet
R_M		Sensor Resistance at Middle of Range	
R_H		Sensor Resistance at the Top of Range	
R_1		R_1 Value	Eq. 8
R_2		R_2 Value	Eq. 9
R_3		R_3 Value	Eq. 10
Gain		Amplifier Gain	Eq. 11
$V_{TEMPSET}$		Temperature Setpoint Voltage	Eq. 14

Once the component and voltage values are calculated, proceed to the next section to configure the WTCPEVAL board.

Table 5. System Component Values

PARAMETER	VALUE	NOTE
R_{SENSE}	0.008 Ω	Output current sense resistor; internal to WTCP controller
V_{REF}	2.45 V	Nominal value is 2.45 V; for best results measure the actual value

SET THE TEC VOLTAGE LIMIT

The maximum TEC voltage is set by applying a voltage at VLIM (pin 16). The WTCP is configured so the voltage limit is the same whether heating or cooling.

First, find the maximum voltage (V_{MAX}) in the datasheet for your TEC.

Then calculate the voltage to apply to VLIM using **Eq. 1**.

$$\text{Eq. 1. } V_{VLIM} = V_{MAX} / 5$$

The TEC voltage limit can be set by applying a voltage to pin 16, or by using the resistor divider network shown in **Figure 8**; use **Eq. 2** to determine the values of R_A , R_B , and VLIM.

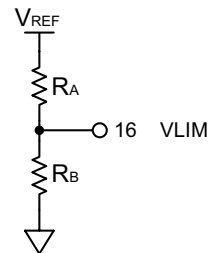

Figure 8. VLIM Resistor Divider Circuit

$$\text{Eq. 2. } V_{LIM} = (V_{REF} \times R_B) / (R_A + R_B)$$

SET THE TEC CURRENT LIMITS

The TEC cooling and heating current limits are set by applying a voltage to ILIMC and ILIMH (pins 14, 15). Find the maximum current (I_{MAX}) in the datasheet for your TEC, then calculate the voltage to apply to ILIMC and ILIMH using **Eq. 3** and **Eq. 4**:

$$\text{Eq. 3. } V_{ILIMC} = (I_{MAX_C} * 25 * R_{SENSE}) + (V_{REF} / 2)$$

$$\text{Eq. 4. } V_{ILIMH} = (V_{REF} / 2) - (I_{MAX_H} * 25 * R_{SENSE})$$

Refer to **Table 5** for R_{SENSE} and V_{REF} values.

SET THE TEMPERATURE CONTROL RANGE

The WTCP is used with Negative Temperature Coefficient (NTC) thermistor sensors.

Thermistors have a nonlinear resistance vs. temperature curve over a wide temperature range, but over a narrow range a linear response can be approximated. The WTCP is configured to operate within a temperature range, and the controller linearizes the thermistor curve within that range.

The temperature control range does not have to include ambient even if the load will be at ambient when the controller is first powered on. If the actual temperature is outside the temperature control range, the controller may drive the TEC to the current limit until the actual temperature is within the control range, so it is critical to properly set the limit current and voltage.

The temperature control range is defined by an external resistor network. **Figure 9** shows the schematic of resistors R_1 , R_2 , and R_3 on the evaluation board; and the same layout applies to custom-designed circuits.

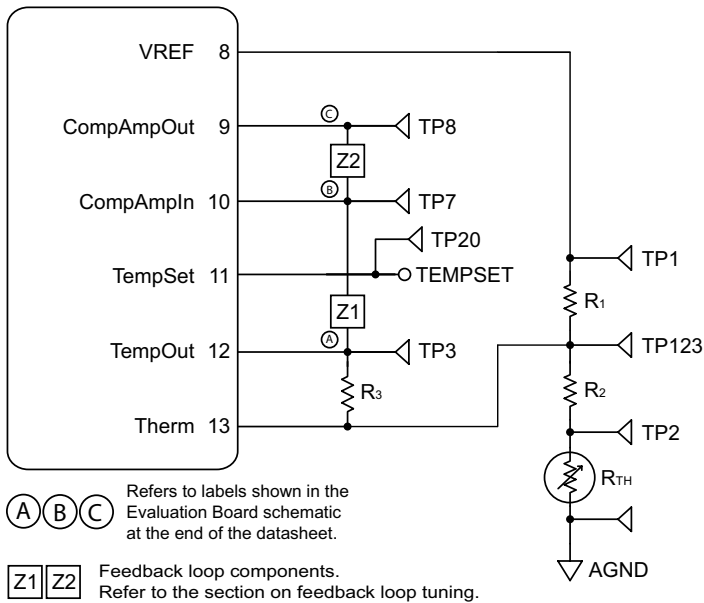

Figure 9. Temperature Control Resistor Network

Determine the temperature design range for your application: T_{LOW} and T_{HIGH} are the endpoints of the temperature range, T_{MID} is the center of the range. Find the corresponding thermistor resistance (R_{TH}) values from the sensor datasheet:

Eq. 5. $R_L = R_{TH}$ at $T_{LOW} - 2\%$

Eq. 6. $R_M = R_{TH}$ at T_{MID}

Eq. 7. $R_H = R_{TH}$ at T_{HIGH}

Note that R_L must be calculated at a temperature value that is 2% below the minimum temperature of the range.

R_1 , R_2 , and R_3 are dependent on the values R_L , R_M , and R_H used to define the temperature control range.

Calculate R_1 , R_2 , and R_3 values using **Eq. 5** through **Eq. 10**.

Eq. 8. $R_1 = \left(\frac{(R_L R_M + R_M R_H - 2R_L R_H)}{(R_L + R_H - 2R_M)} \right) + R_M$

Eq. 9. $R_2 = R_1 - R_M$

Eq. 10. $R_3 = R_1 * (R_1 + R_L - R_M) / (R_L - R_M)$

Calculate the circuit gain using **Eq. 11**.

Eq. 11. $Gain = 2 * R_3 / R_M$

The circuit gain value must be kept between 10 and 30. If the gain value is too low, the control range is too wide and control resolution about the setpoint will be poor.

Conversely, if the gain is too high the control range is too narrow, and the controller will be unstable.

If necessary, adjust the control range endpoints and recalculate the resistor values.

MONITOR EQUIVALENT VOLTAGE OF THE ACTUAL TEMPERATURE

The voltage on TempOut (pin 12, TP3/TEMP_MON testpoint) represents the actual temperature measured by the sensor. The range of $V_{TempOut}$ is (0.05 V at T_{LOW}) to (V_{REF} at T_{HIGH}). When $V_{TempOut} = 1.25$ V the actual temperature is at the center of the control range.

The actual temperature does not correspond in a directly measureable way to the thermistor voltage. Use **Eq. 12** to calculate the equivalent voltage for a particular temperature/resistance. Use **Eq. 13** to calculate the thermistor resistance for a given $V_{TempOut}$ voltage.

Eq. 12.

$$V_{TempOut} = \frac{V_{REF}}{2} \left(\frac{R_3}{R_{TH} + R_2} - \frac{R_3}{R_1} + 1 \right)$$

Eq. 13.

$$R_{TH} = \left(\frac{0.5 * V_{REF} * R_1 * R_3}{(V_{TempOut} * R_1) - (0.5 * V_{REF} * R_1) + (0.5 * V_{REF} * R_3)} \right) - R_2$$

SET THE TEMPERATURE SETPOINT

The temperature setpoint is controlled by a voltage on TempSet (pin 11, T_SET testpoint). The voltage is calculated using **Eq. 14**, based on the thermistor resistance at the setpoint temperature and the values of R_1 , R_2 , and R_3 .

Eq. 14.

$$V_{TempSet} = \frac{V_{REF}}{2} * R_3 * \left(\frac{1}{R_3} - \frac{1}{R_1} + \frac{1}{R_2 + R_{TH}} \right)$$

MONITOR THE TEC VOLTAGE

The voltage output on VTEC (pin 17, TP6 testpoint) is proportional to the voltage drop across the TEC (V_{TEC}), measured at the pins of the WTCP. Two equations are used, depending on whether V_{VTEC} is greater than or less than $V_{REF}/2$; see **Eq. 15** and **Eq. 16**

If $V_{VTEC} > V_{REF}/2$, the TEC is operating in Cooling mode.

$$\text{Eq. 15. } V_{TEC} = 4.071 * V_{VTEC} - 4.468$$

If $V_{VTEC} < V_{REF}/2$, the TEC is operating in Heating mode.

$$\text{Eq. 16. } V_{TEC} = 4.116 * V_{VTEC} - 5.351$$

MONITOR THE TEC CURRENT

The voltage output on ITEC (pin 18, TP5 testpoint) is proportional to the current flowing through the TEC (I_{TEC}), defined by **Eq. 17**.

$$\text{Eq. 17. } I_{TEC} = 4.618 * V_{ITEC} - 5.749$$

When $V_{ITEC} < V_{REF}/2$ volts, current is flowing in the heating direction. When $V_{ITEC} > V_{REF}/2$ volts, current is flowing in the cooling direction based on NTC thermistor.

TEMPGOOD PIN

The controller will indicate when the voltage on Therm (pin 13) is within 100 mV of the TempSet voltage by switching TempGood (pin 5) to Logic-High. The pin will source up to 5 mA and can be used to drive an LED as shown in **Figure 10**.

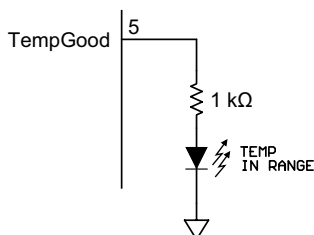

Figure 10. TempGood Status LED

CONFIGURE THE WTCP5V5A EVALUATION BOARD

The evaluation board provides full access to the critical functions and signals of the WTCP controller. These instructions describe in detail the features and functions of the WTCPEVAL Board illustrated in **Figure 11**. The entire evaluation board schematic is shown in **Figure 22 on page 19**.

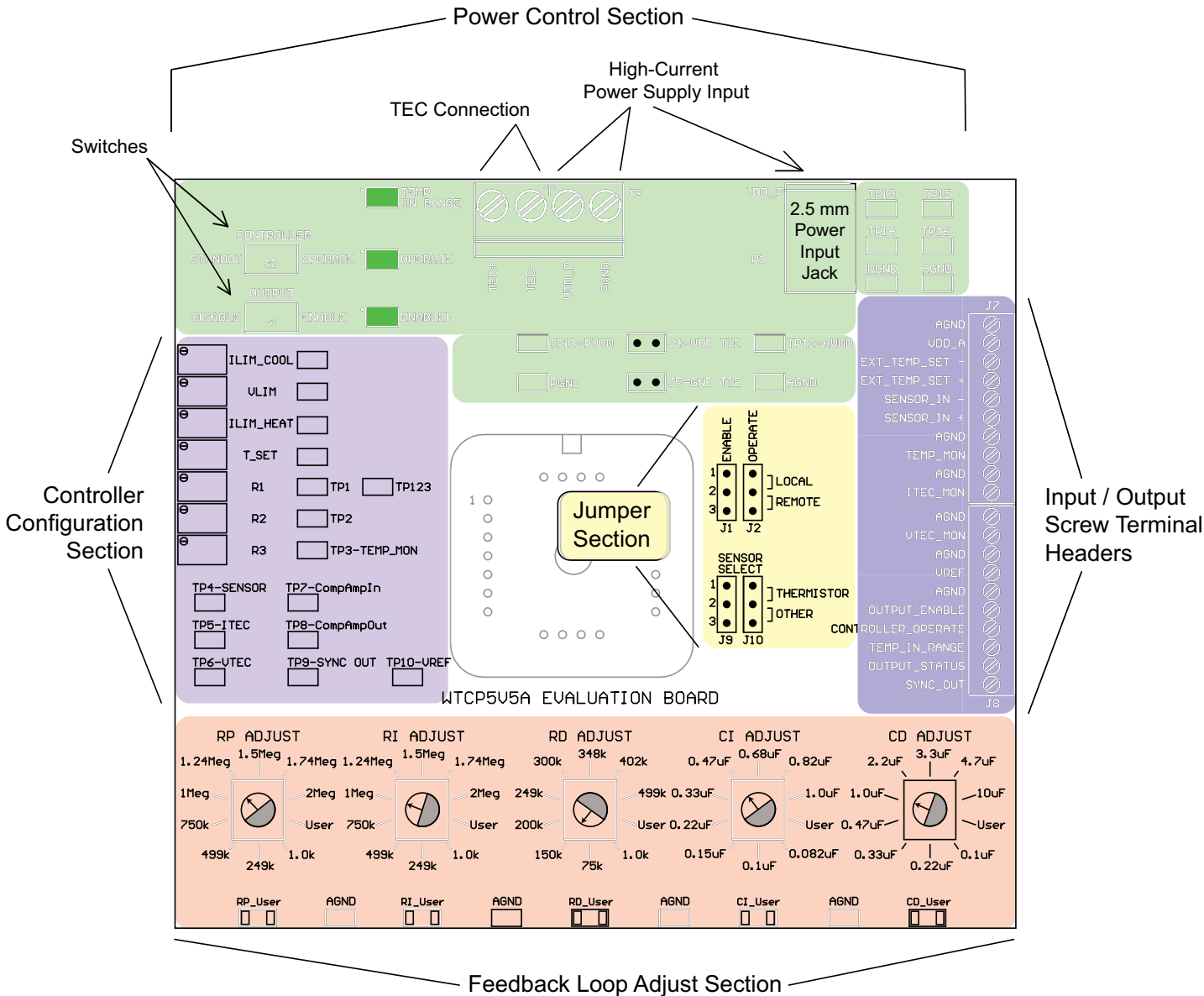

Figure 11. WTCPEVAL Board



INSTALL THE WTCP5V5A ON THE WTCPEVAL BOARD WITH THE POWER SUPPLIES SWITCHED OFF. ANY TIME POWER IS APPLIED TO THE WTCPEVAL BOARD, VOLTAGES ARE REPRESENTED ON THE PINS OF THE WTCP SOCKET.

Note the orientation of Pin 1 marked on the WTCP and on the WTCPEVAL board.

POWER CONTROL SECTION

Figure 12 shows the Power Control Section of the WTCP5V5A evaluation board. The primary function of this section is to control power input to the evaluation board, and also to Enable / Disable the TEC drive current.

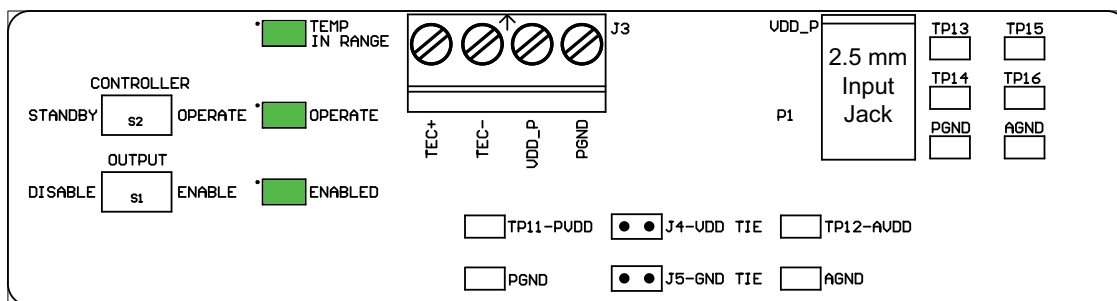

Figure 12. Power Control Section on WTCP5V5A EVAL

Switches and LED Indicators

- The **CONTROLLER** switch places the WTCP in **Standby** or **Operate** mode. An LED on the evaluation board indicates that the controller is in **Operate** mode.
- The **OUTPUT** switch controls the output stage of the WTCP. The controller must be in **Operate** mode in order for the output to be enabled. An LED on the evaluation board indicates that the output is **ENABLED**.
- The **TEMP IN RANGE** LED indicates that the sensor voltage is within ± 25 mV of the setpoint voltage.

Controller Standby Vs. Operate Switch

The WTCP can be placed in Standby or Operate mode using the CONTROLLER switch on the evaluation board. The input signal is ACTIVE_LO (WTCP pin 2; eval board J8-7) to place the controller in Standby mode.

When in Standby mode, current draw of the WTCP is ~ 5 μ A. In Operate mode, current draw is ~ 15 mA. Power is applied to the WTCP with the controller in Standby mode. Do not insert or remove the WTCP from the WTCPEVAL board when the CONTROLLER switch is in Standby position.

When switched from Standby to Operate mode, the controller slow-starts the duty cycle of the pulse width modulator over a 15 ms period. In Operate mode all analog functions of the WTCP are active and can be monitored.

Output Enable vs. Disable Switch

The output stage of the WTCP is enabled or disabled using the OUTPUT switch on the evaluation board. The input signal is ACTIVE_LO (WTCP pin 4; eval board J8-6) to disable the output.

The controller must be in Operate mode and the output must be enabled for the WTCP to drive current to the TEC.

Power Input and TEC Connections

High-current power can be input to the evaluation board using either the screw terminal block, or the 2.5 mm jack. The power supply must be rated to supply at least 1.1-times the maximum rated TEC current.

TEC connections are made by the screw terminal block. Connect the positive wire of the TEC module to the TEC+ terminal, and the negative lead to the TEC- terminal.

VDD TIE and GND TIE Jumpers

The VDD_TIE and GND_TIE jumpers are used to connect the V_{DD_P} and V_{DD_A} power supply inputs so that a single power supply can be used. Reference Figure 13 below. If the inputs are tied, use the high-current connections, either the 2.5 mm jack or the high-current screw terminal. Connect a power supply only to V_{DD_P} and do not connect a power supply to V_{DD_A} .

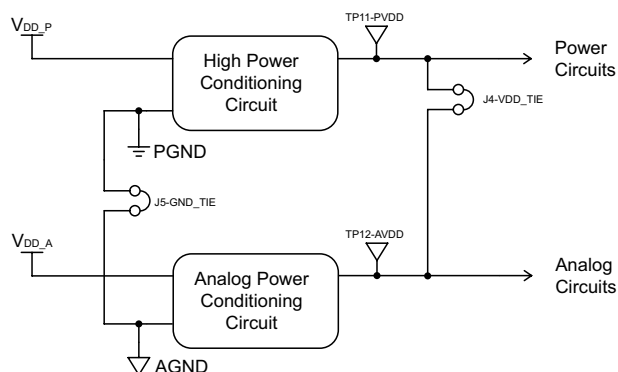

Figure 13. Power Supply Jumper Function

A detailed schematic is shown in Figure 24 on page 20.

JUMPER SECTION

The jumpers are located just to the right of the WTCP socket, and are shown in **Figure 14**.

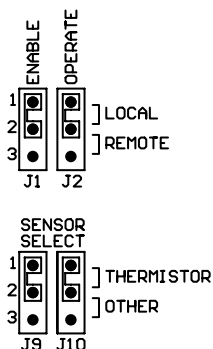

Figure 14. Jumper Section

Local vs. Remote Operation

The evaluation board can be configured to use the onboard CONTROLLER and OUTPUT switches, or to reference the signals input on the J8 screw terminal connector. Refer to **Table 6** for jumper settings, then place the jumpers on J1 and J2 accordingly.

Table 6. Local / Remote Jumper Configuration

FUNCTION	PLACE THE JUMPER OVER
Local Output Enable	J1: 1-2
Remote Output Enable	J1: 2-3
Local Controller Operate	J2: 1-2
Remote Controller Operate	J2: 2-3

While setting up and configuring the WTCPEVAL, it is usually more convenient to use the onboard switches; set the jumpers to the LOCAL positions.

Temperature Sensor Type

Jumpers J9 and J10 must be configured identically in order for the sensor input circuit to work properly.

Current product revision only supports thermistors, so the Sensor Select jumpers must be positioned over pins 1 & 2 of J9 and J10 for the WTCPEVAL to function.

Note that the WTCPEVAL board is optimized for 10 kΩ thermistors. Setpoint range is between 2 and 17 kΩ.* The WTCP itself can support a setpoint range of 2 to 50 kΩ with excellent stability. Setpoints ranging from 50 to 200 kΩ are supported by the WTCP, but with decreasing stability.

* Range can be extended to match WTCP. Contact factory for details.

CONTROLLER CONFIGURATION SECTION

Figure 15 illustrates the controller configuration section, which is used to set the TEC current and voltage limits, and the temperature range and setpoint.

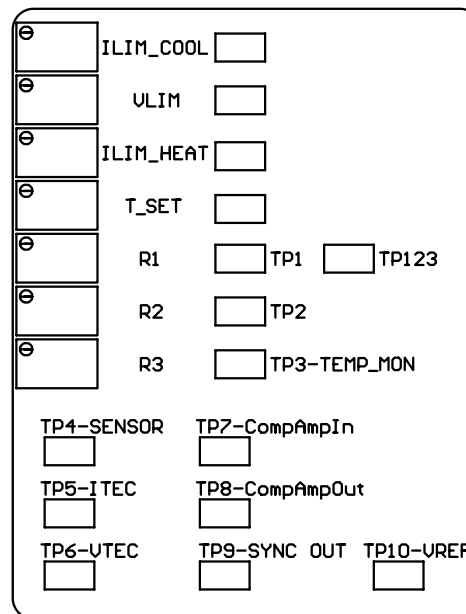

Figure 15. Controller Configuration Section

The thermistor and the power supply must be removed from the WTCPEVAL board in order to configure the temperature control range potentiometers.

Set the Temperature Control Range

On the evaluation board trimpots R_1 , R_2 , and R_3 are used to set the temperature control range. Refer to **Figure 15** for trimpot and testpoint locations.

With power disconnected, the thermistor removed, and the **CONTROLLER** switch set to **Standby**, connect one lead of the ohmmeter to TP123.

Connect the other lead of the ohmmeter to TP1 and adjust R_1 until the TP1—TP123 resistance matches the value calculated in **Eq. 8** (or the value produced from the component selector software).

Measure the resistance of TP2—TP123 and adjust R_2 to match the value calculated in **Eq. 9**.

Measure the resistance of TP3—TP123 and adjust R_3 to match the value calculated in **Eq. 10**.

Set the TEC Voltage Limit

The TEC voltage limit is set using the trimpot on the evaluation board. The resistor network shown in **Figure 16** is the configuration used on the WTCPEVAL board.

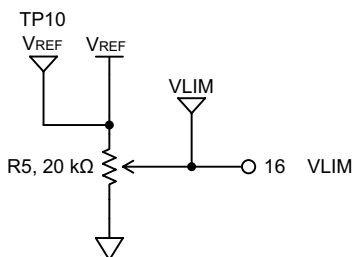

Figure 16. VLIM Resistor Divider

With power applied and the board in Operate mode, monitor the voltage on the VLIM testpoint and adjust the VLIM trimpot until the voltage matches the value calculated in **Eq. 1**.

Set the TEC Current Limit on the Evaluation Board

The resistor network shown in **Figure 17** is used on the WTCPEVAL board.

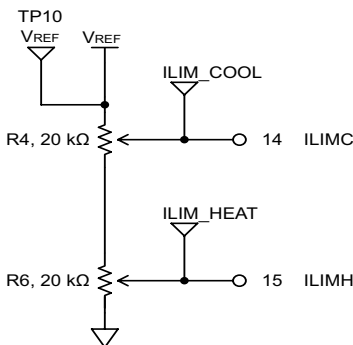

Figure 17. ILIM Resistor Circuit on Evaluation Board

To set I_{LIMC} , monitor ILIM_COOL with power applied and the board in Operate mode. Adjust the ILIM_COOL trimpot until the voltage matches the value calculated in **Eq. 3**.

To set I_{LIMH} , monitor ILIM_HEAT with power applied and the board in Operate mode. Adjust the ILIM_HEAT trimpot until the voltage matches the value calculated in **Eq. 4**.

Adjust the Temperature Setpoint

With power applied and the board in Operate mode, connect the voltmeter to the T_SET testpoint and adjust the trimpot until the voltage matches the value calculated in **Eq. 14**.

TUNING THE WTCP5V5A

Once the WTCP is configured, the controller output can be enabled and the final configuration steps executed.

The next step toward using the WTCP in your application is to tune the feedback loop in order to maximize temperature control stability and accuracy, and minimize settling and transient response time. The control loop is a modified Proportional-Integral-Derivative (PID) loop, and does not tune the same as a conventional PID loop.

It is important to note that the feedback loop does not tune the same as conventional PID feedback control loops. In conventional PID loops, each parameter (P, I, D) can be independently tuned. With the WTCP5V5A feedback loop, each parameter relates to the others, and this makes loop tuning more complicated.

FEEDBACK LOOP ADJUST SECTION

The Feedback Loop Section, **Figure 18**, features five rotary switches to adjust the component values of the feedback loop algorithm.

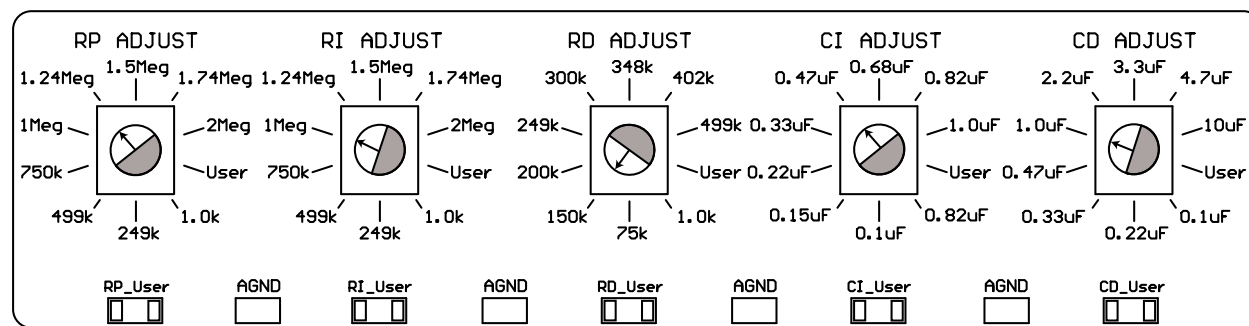
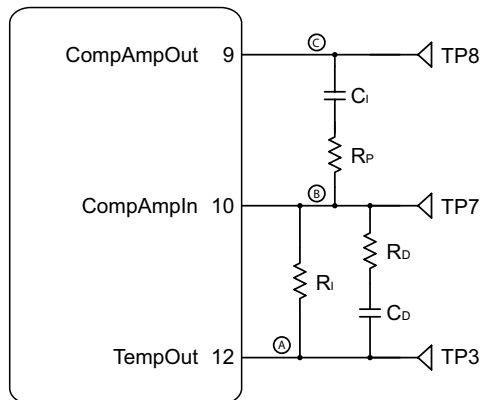

Figure 18. Feedback Loop Adjust Section

The schematic of the feedback loop is shown in **Figure 19**.



(A)(B)(C) Refers to labels shown in the Evaluation Board schematic at the end of the datasheet.

Figure 19. Feedback Loop Schematic

The flat on the rotary switch selector points to the value that is selected; for example the switch in **Figure 20** selects 2 M Ω for R_p (Proportional Gain resistor).

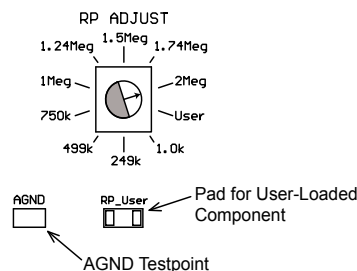

Figure 20. Feedback Switch Position

The switches are each preloaded with values that are listed on the circuit board silkscreen, and each also includes surface mount contact pads for a user-loaded component (1206 package). Set the switch to the USER position when using a user-loaded component. Setting the switch to USER when there is no component effectively creates an open circuit in that portion of the feedback loop (**Figure 19**).

Configure the Control Loop

Use the following guidelines to begin tuning the feedback loop for your load and application. The information regarding component value selection applies whether you are using the WTCPEVAL board or integrating the WTCP5V5A into your own circuit.

On the evaluation board, set the switches to the values shown in **Table 7** for the load that matches yours the closest. Initial time-to-temperature is when the actual temperature first reaches and crosses the setpoint temperature after starting at ambient temperature.

Table 7. Feedback Loop Tuning

PARAMETER	NAME	Best Values for Loads with Initial Time-to-Temperature Crossing			
		0-12 sec	30 sec	45 sec	60 sec
RP	Proportional Resistance	1.24 MΩ	1.24 MΩ	1 MΩ	1.24 MΩ
RI	Integral Resistance	1 MΩ	1 MΩ	1.24 MΩ	1.24 MΩ
RD	Derivative Resistance	150 kΩ	150 kΩ	1 kΩ	1 kΩ
CI	Integral Capacitance	0.82 μF	0.47 μF	0.68 μF	10 μF
CD	Derivative Capacitance	3.3 μF	0.47 μF	10 μF	10 μF

First configure the WTCP for your application, following the instructions above to set the current and voltage limits, temperature range, and setpoint. With the TEC connected, set the WTCPEVAL Controller switch to Operate.

Connect channel 1 of a two-channel oscilloscope to TempOut (pin 12, TP3 testpoint). Connect channel 2 to ITEC (pin 18, TP5 testpoint). Connect the ground of each probe to AGND testpoints.

Switch on the oscilloscope and set it to a long time scale, about 2.5 seconds per division or 5 s / div. Adjust the vertical scale on both channels to 20 mV / div and center the traces on the oscilloscope screen.

While performing the coarser steps of the tuning process, monitor the TEC current on channel 2 of the oscilloscope. The TEC current gives a good indication of the controller action, and whether or not the control loop is oscillating, over-damped, or properly damped. Load temperature is the ultimate response: monitor channel 1 when making the final adjustments to make sure the actual temperature response is suitable for the application.

Disable the output when adjusting the loop parameters. After making an adjustment, switch the output to Enable, and watch the response on the oscilloscope.

The goal is to find feedback loop parameters that result in load temperature settling with little or no overshoot of the setpoint, but also without taking too long.

The initial parameters give in **Table 7** are likely not ideal for your application, and the TEC current and load temperature may oscillate, possibly with the TEC current driving from the limit-to-limit. If this is the case, then follow these instructions to fine-tune the control response.

Adjust CD and RD

If the value of CD is either much too high or much too low, the control response will oscillate. The temperature may eventually settle, but not necessarily. Disable the output, adjust the CD switch, and re-enable the output. If the amplitude of the oscillation is reduced, continue adjusting CD in the same direction to achieve the best possible response. The control response should oscillate about the setpoint. If it does not eventually settle, continue on to adjust RD.

If RD is too high the control response will oscillate about the setpoint. If this is the case, decrease RD until the oscillations are damped as much as possible. If RD is too low, the response will be overdamped.

Adjust CI

If CI is too small the load will oscillate about the setpoint, but may eventually settle. If CI is too large, the response will be over-damped, and will take unnecessarily long to settle to the setpoint.

Adjust CI, either to a higher or lower value. If the response is worse, adjust CI in the opposite direction from your initial attempt. If the response is better then adjust CI in the same direction until the controller exhibits a good damping behavior.

Adjust RP and RI

If RP is too low, the response will oscillate; if RP is too high, the response will be over-damped, and will take longer to settle to the setpoint.

Once the best RP value is found, adjust RI. A too-low RI value will oscillate, and may be unstable (increasing oscillation amplitude) while too-high RI will result in an over-damped response that is slower to respond to transient changes.

Fine Tuning

Once the feedback loop is tuned for your application, it may be worthwhile to adjust CD and CI again to find a better response time. Step through the process the same as before, monitoring the ITEC and TempOut responses on the oscilloscope, and adjust the parameters to give the fastest settling time with little overshoot or temperature ringing.

MAXIMUM SAFE CASE OPERATING TEMPERATURE

The controller case temperature will rise due to heating of the internal components, and it is critical that the maximum *Safe Case Operating Temperature* (SCOT) of the WTCP Controller is not exceeded. The maximum SCOT for the WTCP is 85°C.

To determine whether heatsinking is required for safe and reliable operation, first determine the maximum operating current for your application. Then refer to **Figure 21** to determine the case temperature rise ($T_{CASE-RISE}$) for that current.

Then use **Eq. 18** to determine T_{CASE} :

$$\text{Eq. 18. } T_{CASE} = T_{CASE-RISE} + T_{AMBIENT}$$

If T_{CASE} is greater than 85°C, then heatsinking is required. Determine whether a heatsink is sufficient, or if a fan is also required in order to keep T_{CASE} below 85°C.

The heatsink and fan can be ordered from Wavelength Electronics under the WEV3xx-Series Thermal Solution Kits. Contact the factory for more information.

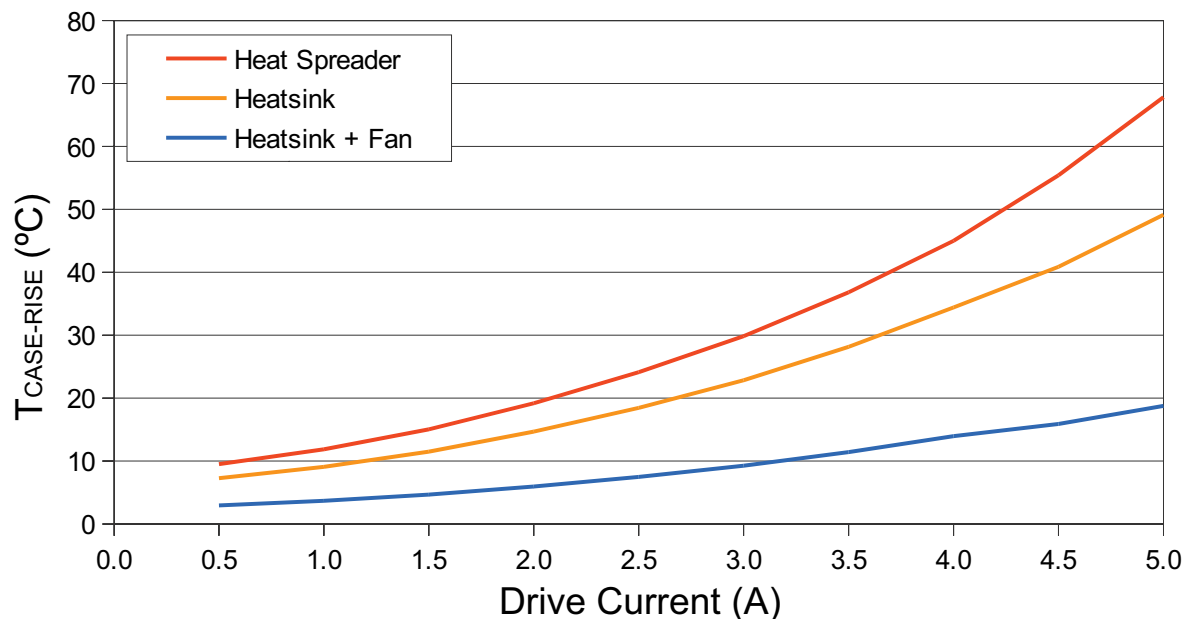

Figure 21. SCOT Chart, WTCP5V5A

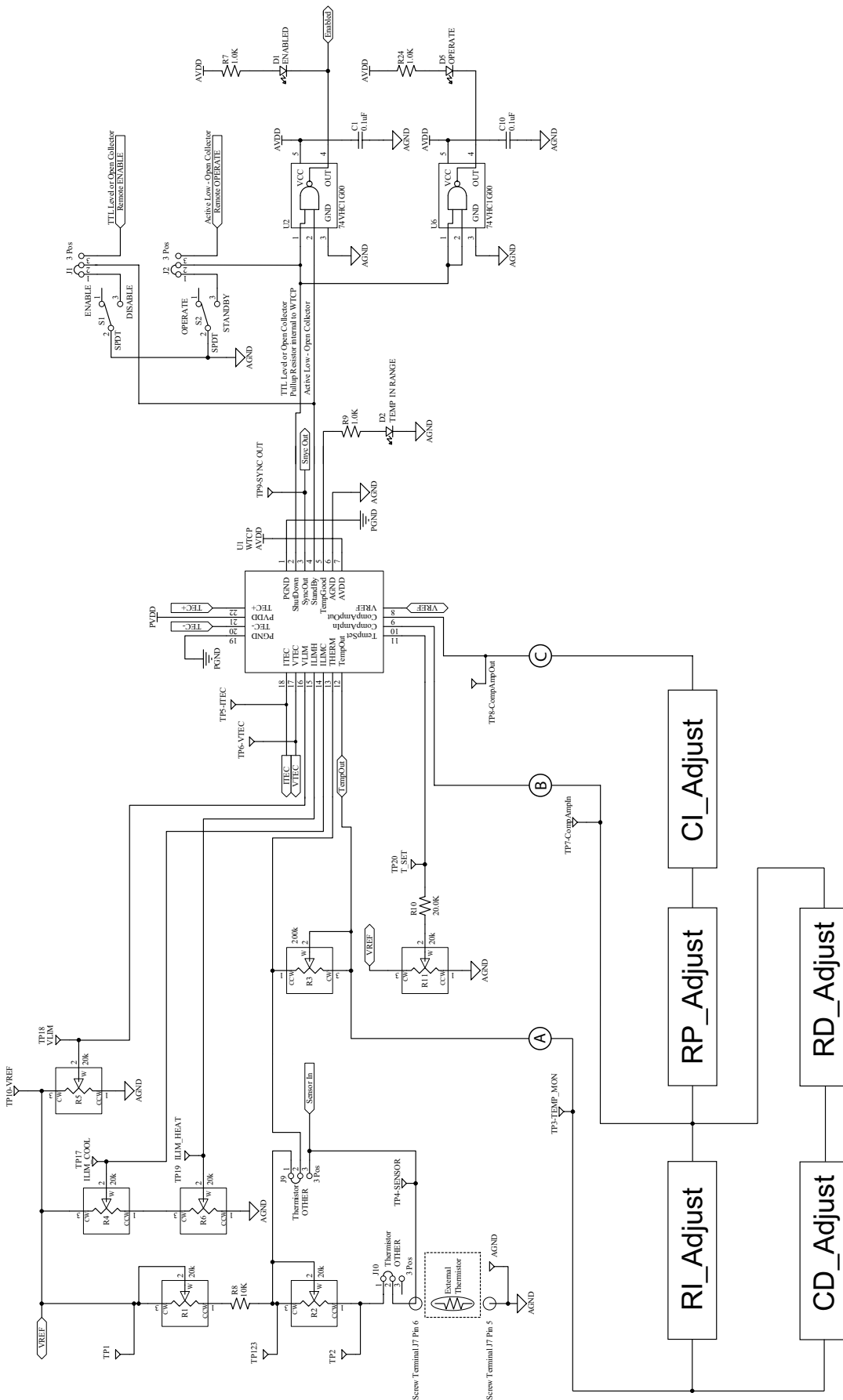

Figure 22. Evaluation Board Schematic

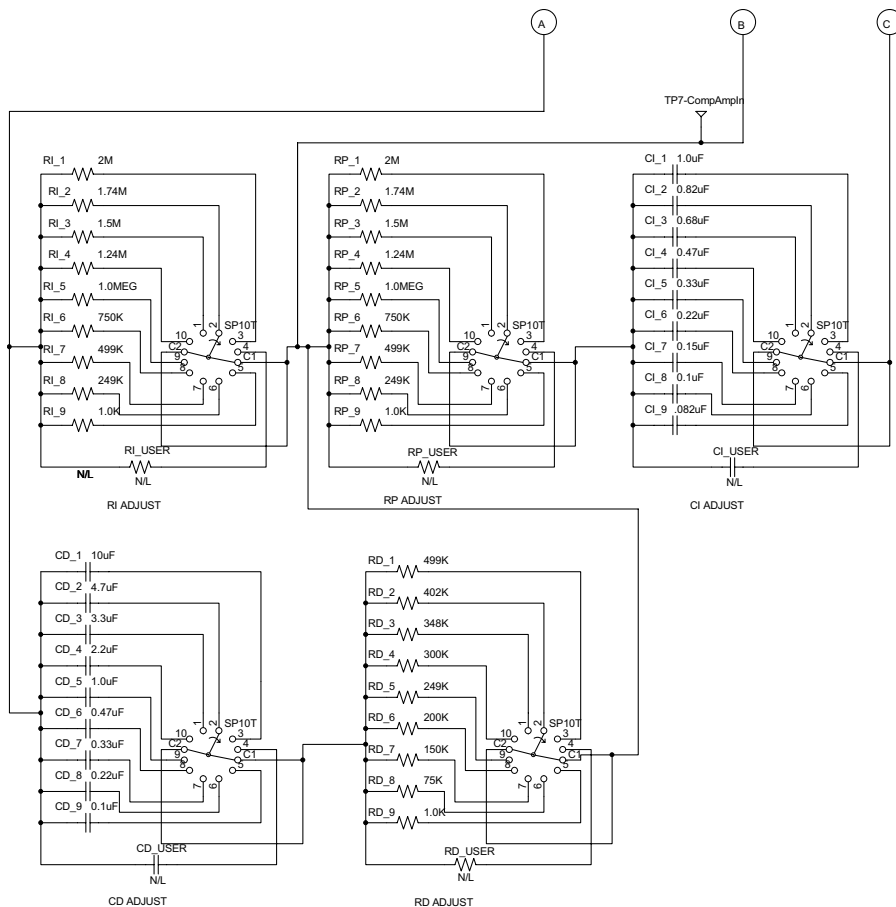

Figure 23. Schematic of P-I-D Fine-Tuning Switches

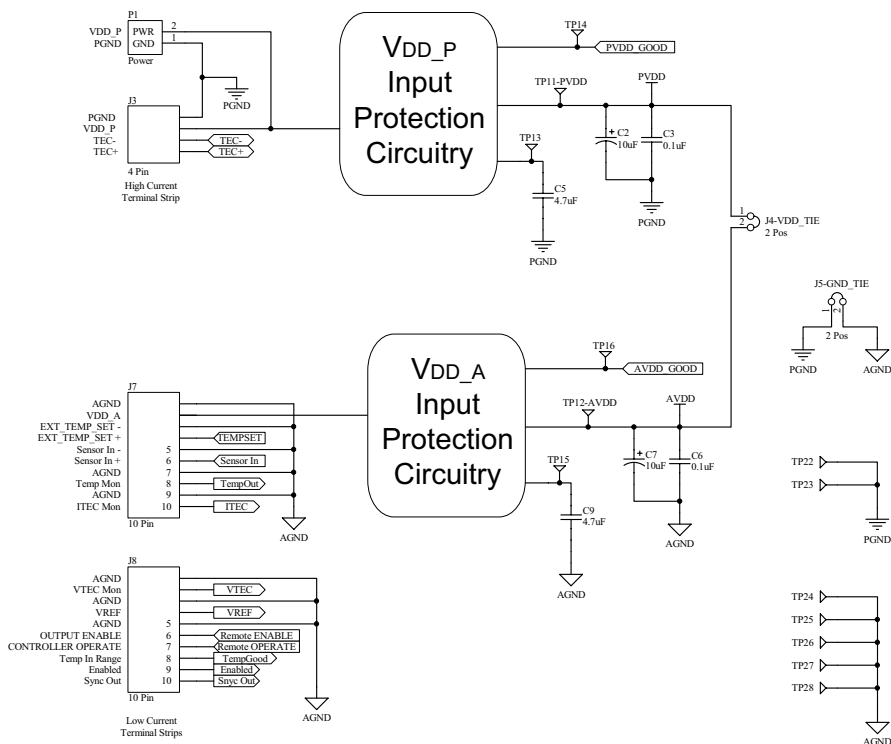

Figure 24. Schematic of Input Power Protection Circuitry

To obtain component value information for the WTCPOEM board, use the WTCPEVAL in conjunction with your application or use Wavelength's Configuration Calculator: <https://www.teamwavelength.com/download/software/wtcp-calc.exe>.

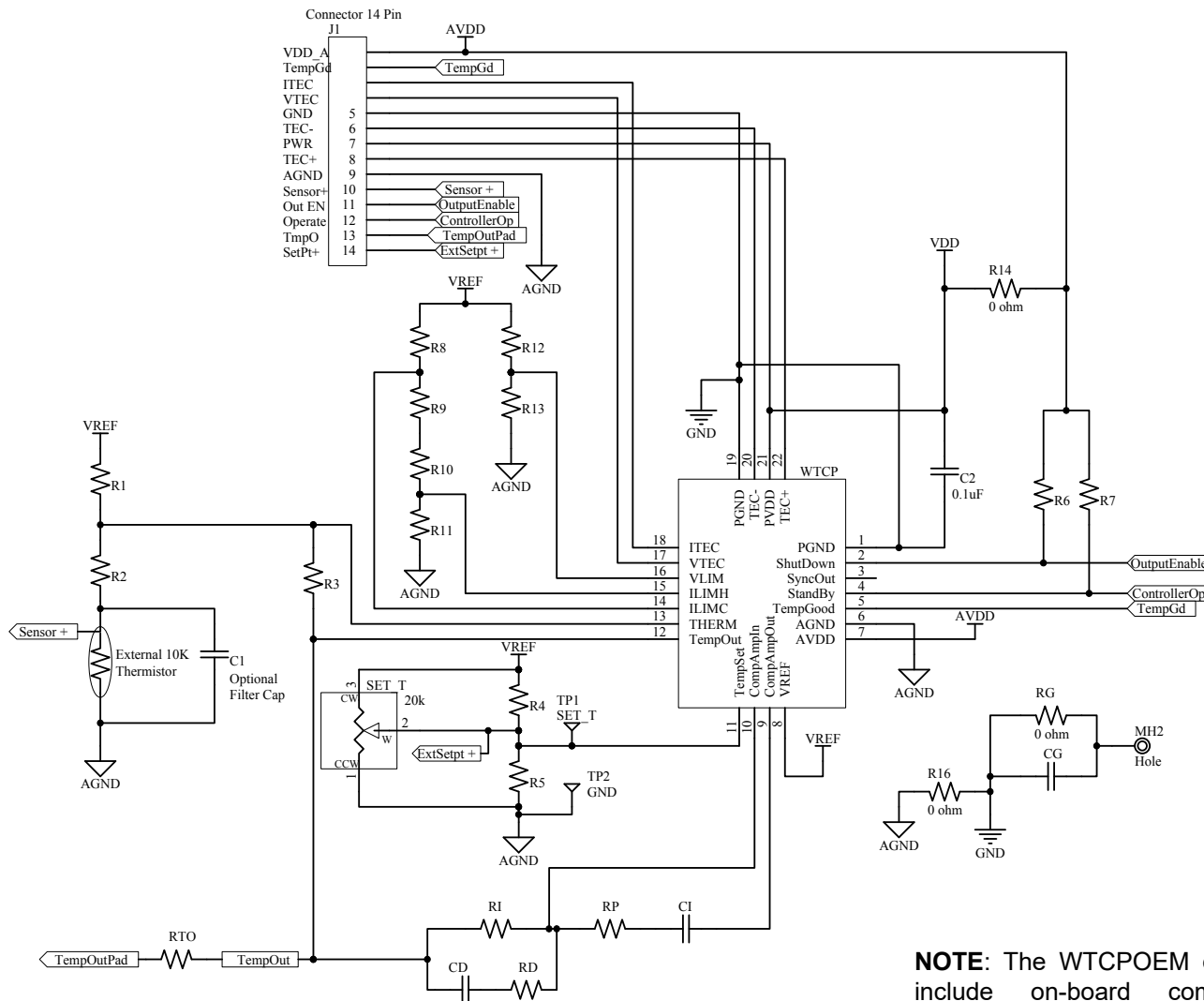

Figure 25. WTCPOEM Schematic

NOTE: The WTCPOEM does not include on-board components unless a custom product variation is ordered.

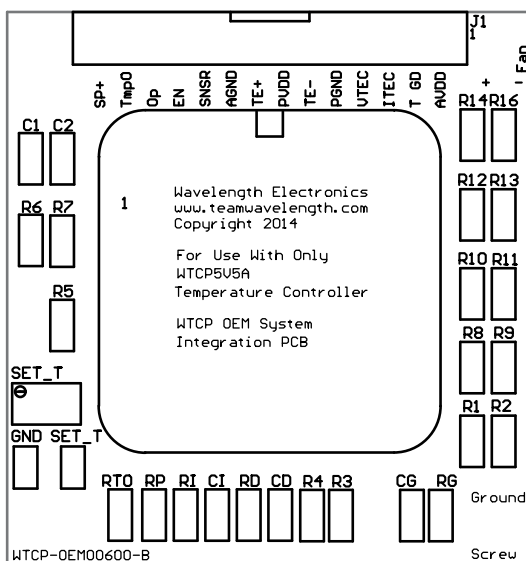

Figure 26. WTCPOEM Component Locator

NOTE: On Rev. A, TempOut pad was GND instead

MECHANICAL SPECIFICATIONS – WTCPOEM

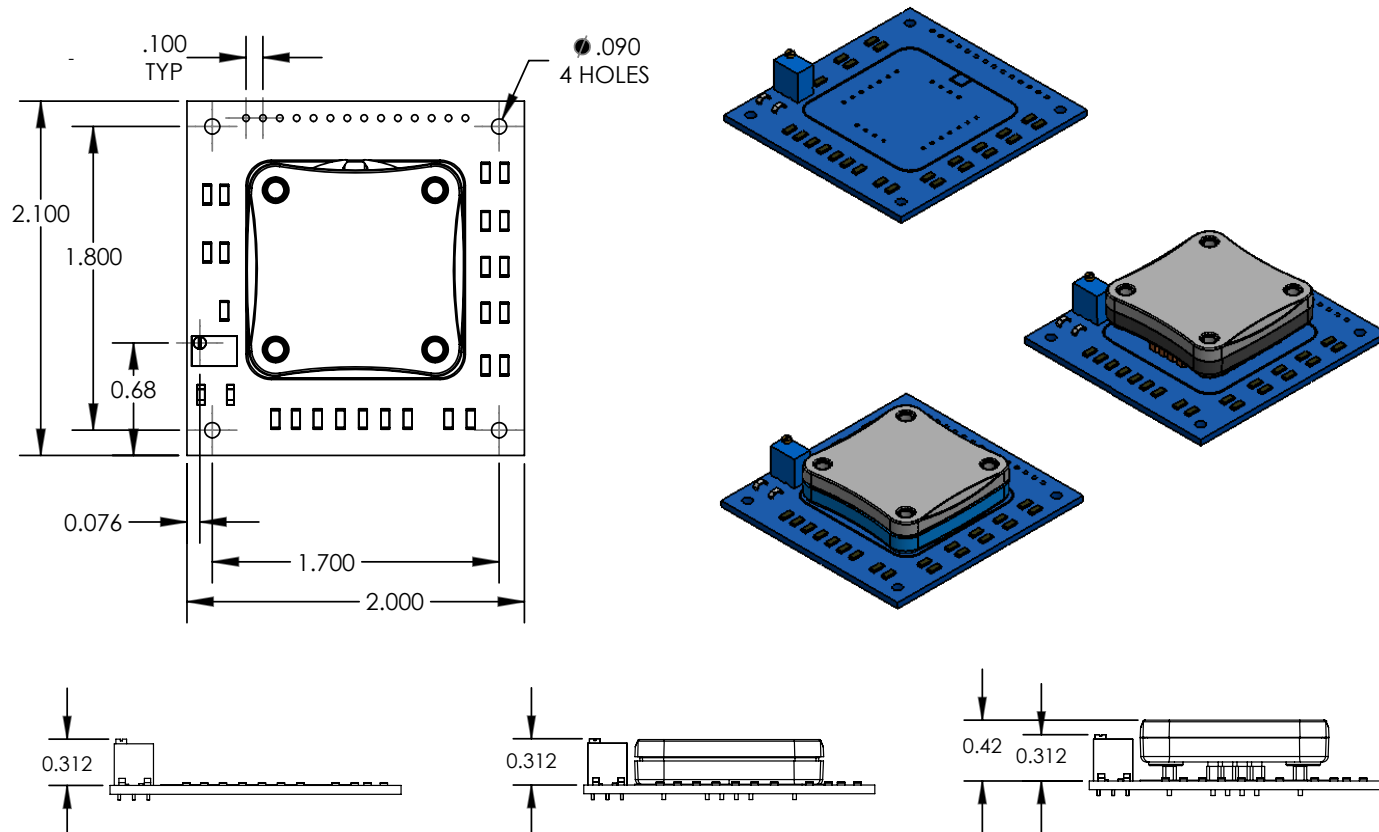

Figure 27. WTCPOEM Dimensions

NOTE: WTCPOEM Board Rev. A hole diameter was 0.071”

NOTE: The WTCPOEM board does not include any on-board components seen in drawings.

For custom components on the WTCPOEM, order a Product Variation by contacting Wavelength Electronics.

All dimensions $\pm 5\%$ tolerance.
Dimensions in [mm] inches.

MECHANICAL SPECIFICATIONS – WTCPEVAL

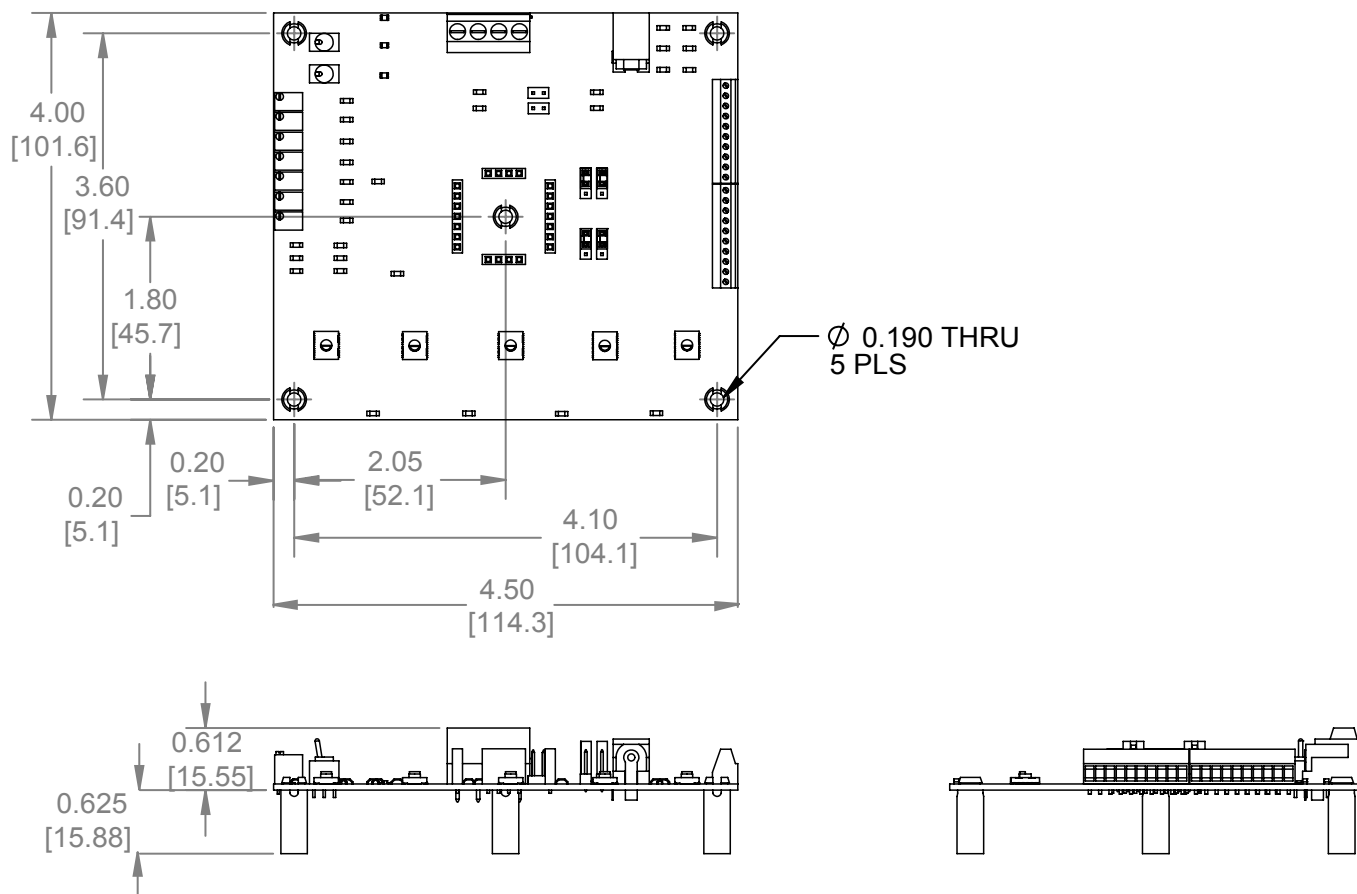

Figure 28. WTCP5V5A with WEV301/302 and WEV300 Thermal Solution Kits

All dimensions $\pm 5\%$ tolerance.
 Dimensions in [mm] inches.

MECHANICAL SPECIFICATIONS – WTCP5V5A

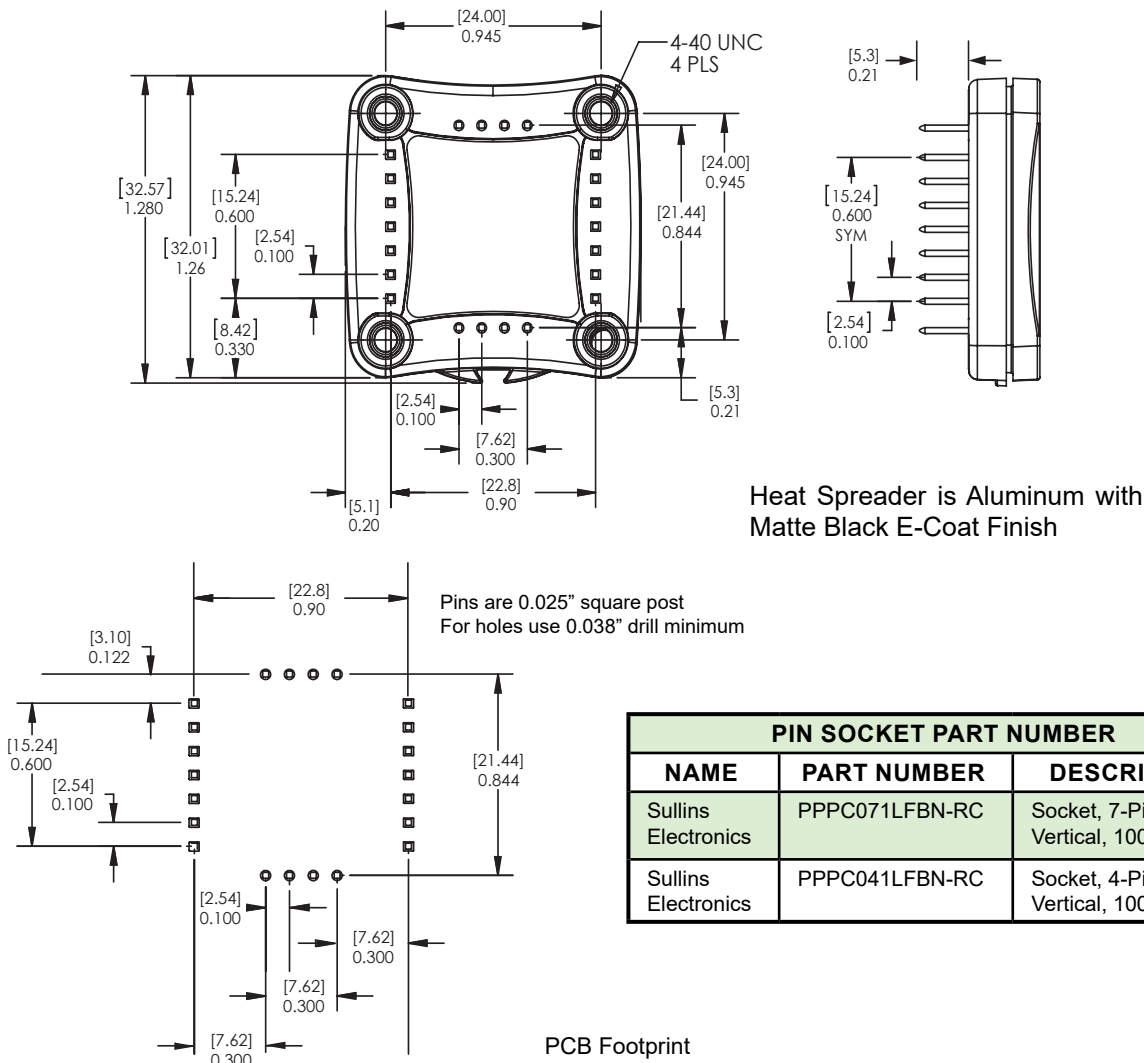

Figure 29. WTCP5V5A Dimensions

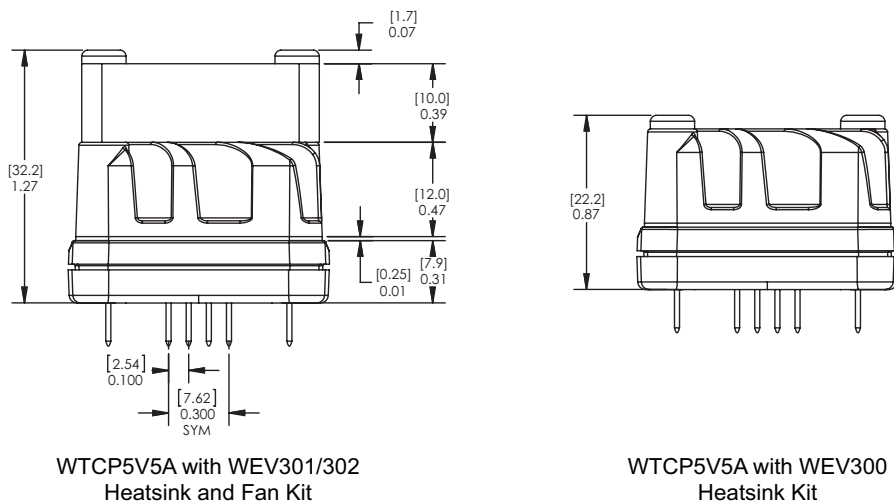

Figure 30. WTCP5V5A with WEV301/302 and WEV300 Thermal Solution Kits

All dimensions ±5% tolerance. Dimensions in [mm] inches.

CERTIFICATION AND WARRANTY

CERTIFICATION

Wavelength Electronics, Inc. (Wavelength) certifies that this product met its published specifications at the time of shipment. Wavelength further certifies that its calibration measurements are traceable to the United States National Institute of Standards and Technology, to the extent allowed by that organization’s calibration facilities, and to the calibration facilities of other International Standards Organization members.

WARRANTY

This Wavelength product is warranted against defects in materials and workmanship for a period of one (1) year from date of shipment. During the warranty period, Wavelength will, at its option, either repair or replace products which prove to be defective.

WARRANTY SERVICE

For warranty service or repair, this product must be returned to the factory. An RMA is required for products returned to Wavelength for warranty service. The Buyer shall prepay shipping charges to Wavelength and Wavelength shall pay shipping charges to return the product to the Buyer upon determination of defective materials or workmanship. However, the Buyer shall pay all shipping charges, duties, and taxes for products returned to Wavelength from another country.

LIMITATIONS OF WARRANTY

The warranty shall not apply to defects resulting from improper use or misuse of the product or operation outside published specifications. No other warranty is expressed or implied. Wavelength specifically disclaims the implied warranties of merchantability and fitness for a particular purpose.

EXCLUSIVE REMEDIES

The remedies provided herein are the Buyer’s sole and exclusive remedies. Wavelength shall not be liable for any direct, indirect, special, incidental, or consequential damages, whether based on contract, tort, or any other legal theory.

REVERSE ENGINEERING PROHIBITED

Buyer, End-User, or Third-Party Reseller are expressly prohibited from reverse engineering, decompiling, or disassembling this product.

NOTICE

The information contained in this document is subject to change without notice. Wavelength will not be liable for errors contained herein or for incidental or consequential damages in connection with the furnishing, performance, or use of this material. No part of this document may be translated to another language without the prior written consent of Wavelength.

SAFETY

There are no user-serviceable parts inside this product. Return the product to Wavelength Electronics for service and repair to ensure that safety features are maintained.

LIFE SUPPORT POLICY

This important safety information applies to all Wavelength electrical and electronic products and accessories:

As a general policy, Wavelength Electronics, Inc. does not recommend the use of any of its products in life support applications where the failure or malfunction of the Wavelength product can be reasonably expected to cause failure of the life support device or to significantly affect its safety or effectiveness. Wavelength will not knowingly sell its products for use in such applications unless it receives written assurances satisfactory to Wavelength that the risks of injury or damage have been minimized, the customer assumes all such risks, and there is no product liability for Wavelength. Examples of devices considered to be life support devices are neonatal oxygen analyzers, nerve stimulators (for any use), auto-transfusion devices, blood pumps, defibrillators, arrhythmia detectors and alarms, pacemakers, hemodialysis systems, peritoneal dialysis systems, ventilators of all types, and infusion pumps as well as other devices designated as “critical” by the FDA. The above are representative examples only and are not intended to be conclusive or exclusive of any other life support device.

REVISION HISTORY

DOCUMENT NUMBER WTCP5V5A00400

REV.	DATE	CHANGE
D	August 2014	Revised Equation 8 and extended warranty
E	November 2014	Added test point identification table.
F	December 2016	Added PCB Footprint dimensions
G	March 2019	Added solderability and washability specifications
H	November 2021	Added WTCPOEM board



WAVELENGTH
E L E C T R O N I C S

51 Evergreen Drive
Bozeman, Montana 59715

406-587-4910 (tel)
406-587-4911 (fax)

Sales & Tech Support

sales@teamwavelength.com

techsupport@teamwavelength.com

