

DATASHEET AND OPERATING GUIDE HTC Series & HTCEVAL PCB

Low Profile, Efficient Temperature Controller & Evaluation Board

HTC SERIES

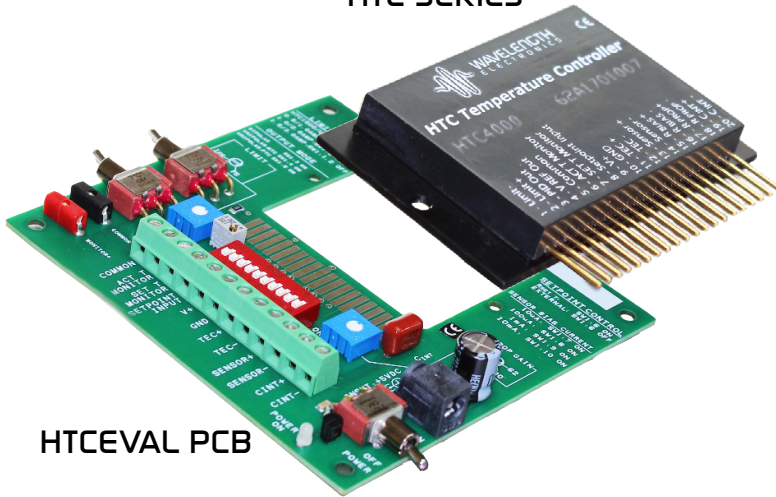

HTCEVAL PCB

PRECISION, STABILITY & VERSATILITY

The advanced and reliable circuitry of the HTC Series achieves 0.0009°C temperature stability with thermistors. Its small, low profile package is ideal for designs with space constraints. The linear, PI control loop offers maximum stability while the bipolar current source has been designed for higher efficiency.

The HTC Temperature Controllers are easily configured for any design. Virtually any type of temperature sensor can be used with the HTC and a built in sensor bias current source simplifies use with resistive temperature sensors. The independently adjustable Proportional Gain (P) and Integrator Time Constant (I) can be modified to optimize temperature overshoot and stability.

FEATURES

- Compact Size - ± 1.5 , ± 3.0 , and ± 4.0 A Models
- +11 V compliance voltage with +12 V input (contact factory for higher voltage operation)
- Interfaces with Thermistors, IC Sensors, & RTDs
- Single supply operation +5 V to +12 V
- Stabilities as low as 0.0009°C with thermistors
- Temperature Setpoint, Output Current Limit, Sensor Bias, Proportional Gain, and Integrator Time Constant are set with external components
- Monitor outputs for Temperature Setpoints and Actual Temperature
- Linear Bipolar or Unipolar Output operates thermoelectrics or resistive heaters

BUILT-IN SAFETY

To protect the device, heat and cool limits can be set independently. This safety feature guarantees that your thermoelectric cooler will never be driven beyond your specified limits.

LEADING EDGE APPLICATIONS

Onboard switches, connectors, and trimpots make the configuration and operation simple with the HTCEVAL PCB. The HTC Series has proven reliable in such diverse fields as medical laser control, defense, communications and manufacturing. The HTC is particularly suited to applications where temperature is scanned across ambient.

CONTENTS

	PAGE
QUICK CONNECT GUIDE	2
PIN DESCRIPTIONS – HTC SERIES	4
ELECTRICAL SPECIFICATIONS – HTC SERIES	5
SAFETY INFORMATION	6
OPERATING INSTRUCTIONS – STANDALONE	7
OPERATION INSTRUCTIONS WITH EVAL BOARD	10
HTCEVALPCB SETTINGS AND OPERATION	12
TERMINAL BLOCK POSITIONS – HTCEVALPCB	13
SAFE OPERATING AREA	17
HTC EVALUATION BOARD SCHEMATIC	18
TROUBLESHOOTING	19
MECHANICAL SPECIFICATIONS	21
CERTIFICATION AND WARRANTY	23

ORDERING INFORMATION

PART NO	DESCRIPTION
HTC1500-62	± 1.5 A Temp Controller (for 0.062" board)
HTC3000-62	± 3.0 A Temp Controller (for 0.062" board)
HTC1500	± 1.5 A Temp Controller (for 0.031" board)
HTC3000	± 3.0 A Temp Controller (for 0.031" board)
HTC4000-62	± 4 A Temp Controller (for 0.062" board)
PWRPAK-5V	+5 V @ 8 A Switching Power Supply
PWRPAK-12V	+12 V @ 3 A Switching Power Supply
HTCEVAL PCB	Evaluation Board, 0.062" thick (Includes HTC Heatsink, and thermal grease)
HTCHTSK	Heatsink for HTC
THERM-PST	Thermal Grease

406-587-4910

www.teamWavelength.com

QUICK CONNECT GUIDE

HTC Series Pin Layout	page 2
HTC Series Quick Connect Diagram	page 2
HTC Series Test Loads	page 3
HTC Evaluation Board Top view	page 10
HTC Eval Board Electrical Schematic	page 18



TO ENSURE SAFE OPERATION OF THE HTC SERIES TEMPERATURE CONTROLLER, IT IS IMPERATIVE THAT YOU DETERMINE THAT THE UNIT WILL BE OPERATING WITHIN THE INTERNAL HEAT DISSIPATION SAFE OPERATING AREA (SOA).

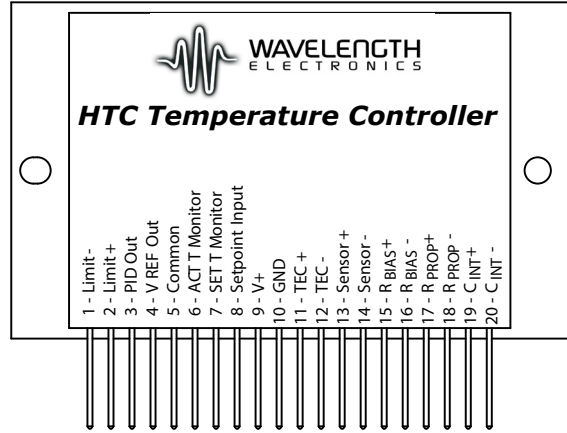

Figure 1. HTC Series Pin-Out, Top View

Visit the Wavelength Electronics website for the most accurate, up-to-date, and easy to use SOA calculator:

www.teamwavelength.com/support/design-tools/soa-tc-calculator/

Figure 1 shows the pin layout and descriptions for the HTC Series.

Figure 2 is the Quick Connect schematic for the HTC Series.

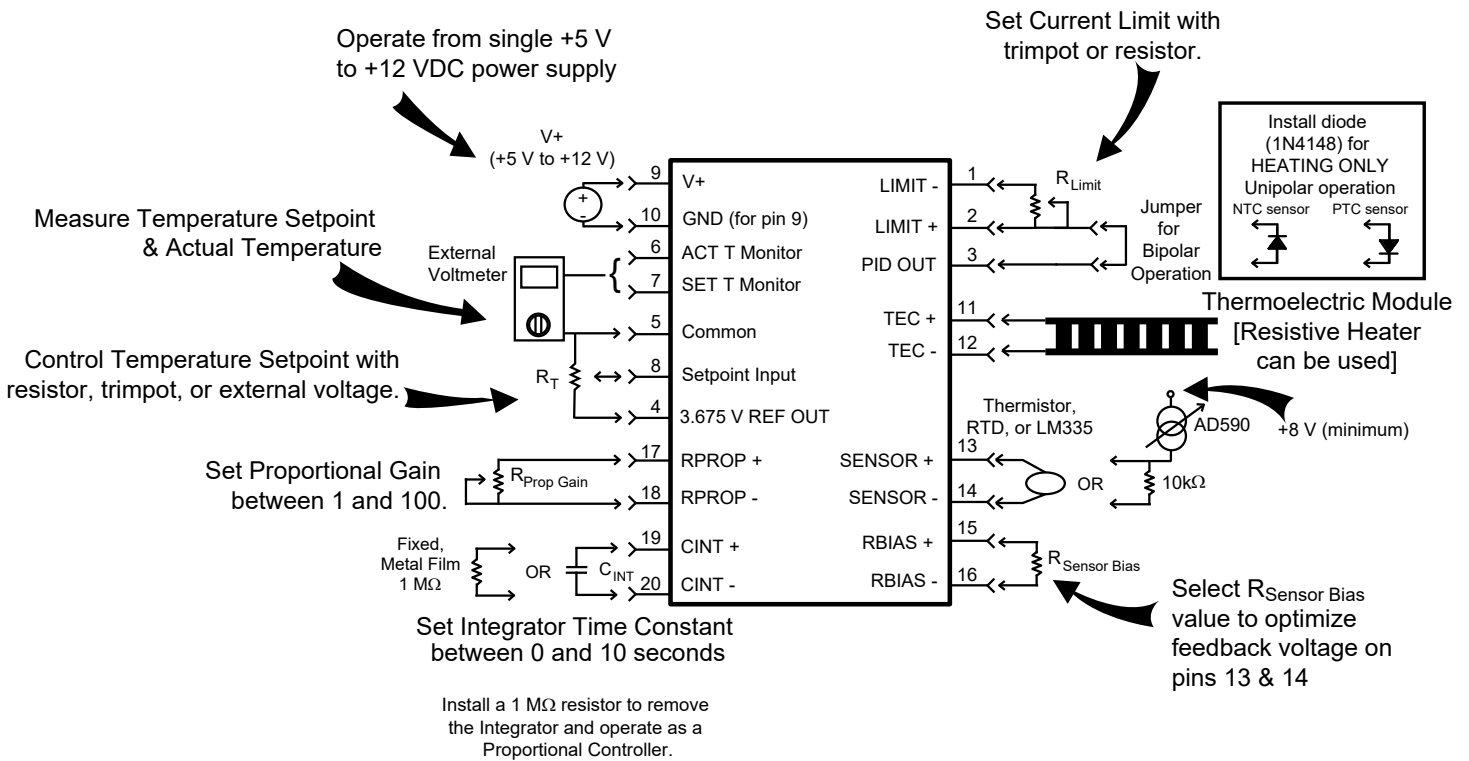

Figure 2. HTC Series Quick Connect

QUICK CONNECT LEGEND				
FUNCTION	HTC Series Alone		HTC Series & EVAL BOARD	
Limits	R_{LIMIT}	STEP 2 on page 8	R_{LIMIT} & SW1:1 & 2	Table 2 on page 12
Control Parameters	R_{PROP}	STEP 5 on page 9	R_{PROP}	Table 2 on page 12
	C_{INT}	STEP 6 on page 9	C_{INT}	Table 2 on page 13
Bias Current	$R_{Sensor Bias}$	STEP 3 on page 8	SW1:7, 8, 9, 10	Table 2 on page 12
Sensor	SENSOR+ & SENSOR-	STEP 4 on page 8	SENSOR+ & SENSOR-	Table 3 on page 13

QUICK CONNECT GUIDE, cont'd

RECOMMENDED TEST LOAD

For setup and configuration, we recommend using a test load in place of the Thermoelectric Cooler (TEC) or resistive heater, connected directly to Pin 11 and Pin 12 on the controller, as shown in **Figure 3**.

Values shown can simulate any load up to the HTC Series maximum of 4 A.

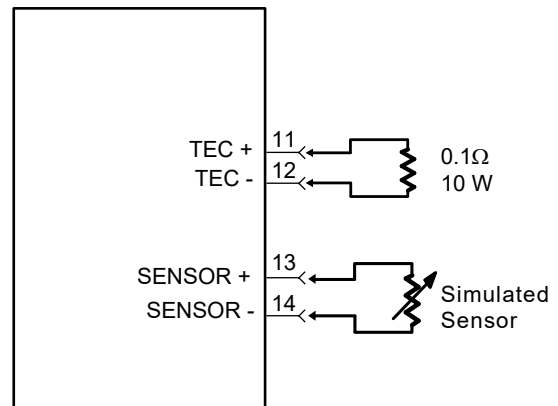

Figure 3. Test Load Configuration

PIN DESCRIPTIONS – HTC SERIES

Table 1. HTC Series Temperature Controller Pin Descriptions

PIN	NAME	NAME ON EVAL	PIN DESCRIPTION
1 2	LIMIT- LIMIT+	R_{LIMIT} & LIMIT RANGE (SW1:1&2)	Resistor value of 0 Ω to 1 M Ω between pins 1 & 2 limits maximum output current.
3	PID OUT	OUTPUT MODE (SW1:3, 4, 5)	Short pins 2 & 3 for bipolar operation. Bipolar operation allows current to flow in both directions and is required when using the controller with TECs. Install diode for unipolar operation (see STEP 1 Output Current Bias - Pins 2 & 3 on page 7 for polarity).
4	V REF OUT		3.675 Volt Reference < 50 ppm stability (15 ppm typical)
5	COMMON	COMMON	Measurement ground. Low current return used only with pins 6, 7, 8. Internally shorted to pin 10.
6	ACT T MONITOR	ACT T & ACT T MONITOR	Temperature voltage monitor. Buffered measurement of voltage across Sensor+ & Sensor-. [1 k Ω output impedance]
7	SET T MONITOR	SET T & SET T MONITOR	Setpoint voltage monitor. Buffered measurement of the setpoint input (pin 8). [1 k Ω output impedance]
8	SETPOINT INPUT	SETPOINT INPUT & $R_{SET T}$ (SW1:6)	Remote Setpoint voltage input. Input impedance = 1 M Ω . Range: 0 to V+ - 1.3 V. Damage threshold: Setpoint < -0.5 V or Setpoint > V+.
9	V+	V+ OR INPUT:+5VDC	Supply voltage input. +5 V to +12 V. Contact Factory for higher voltage operation.
10	GND	GND	Power Supply Ground. Used with pin 9 for high current return.
11 12	TEC+ TEC-	TEC+ TEC-	TEC+ & TEC- supply current to the TEC module. With NTC sensors, connect TEC+ to positive lead of TEC module. With PTC sensors, connect TEC- to positive lead of TEC module.
13 14	SENSOR+ SENSOR-	SENSOR+ SENSOR-	A sensor bias current will source from Sensor+ to Sensor- if a resistor is tied across R_{BIAS+} and R_{BIAS-} . Connect a 10 k Ω resistor across Sensor+ and Sensor- when using an AD590 temperature sensor. See STEP 4 Sensor - Pins 13 & 14 on page 8 .
15 16	R_{BIAS+} R_{BIAS-}	SENSOR BIAS CURRENT (SW1:7, 8, 9, 10)	Resistance between pins 15 & 16 selects sensor current from 1 μ A to 10 mA. Range is 0 Ω to 1 M Ω .
17 18	R_{PROP+} R_{PROP-}	R_{PROP}	Resistance between pins 17 & 18 selects Proportional Gain between 1 & 100. Range is 0 Ω to 495 k Ω .
19 20	C_{INT+} C_{INT-}	C_{INT}	Capacitance between pins 19 & 20 sets the Integral Time Constant between 0 and 10 seconds. 0 seconds (OFF) = 1 M Ω resistor 0.1 to 10 seconds = 0.1 μ F to 10 μ F.

ELECTRICAL SPECIFICATIONS – HTC SERIES

ABSOLUTE MAXIMUM RATINGS	SYMBOL	HTC SERIES	UNIT
Supply Voltage (Voltage on Pin 9 - contact factory for higher V operation) ❶	V +	+5 to +12	Volts DC
Output Current (See SOA chart)	I _{OUT}	±1.5 / ±3.0 / ±4.0	Amps
Power Dissipation, T _{AMBIENT} = +25°C (See SOA Chart)	P _{MAX}	9 (HTC1500/3000) or 19.5 (HTC4000)	Watts
Operating Temperature, case	T _{OPR}	0 to +50	°C
Storage Temperature	T _{STG}	-40 to +125	°C

OPERATING PARAMETER	TEST CONDITIONS	MIN	TYP	MAX	UNITS
Short Term Stability (1-hr) ❷	OFF ambient temperature		0.0009		°C
Short Term Stability (1-hr) ❷	ON ambient temperature		0.002		°C
Long Term Stability (24-hr) ❷	OFF ambient temperature		0.0015		°C
CONTROL LOOP		P	PI		
P (Proportional Gain) ❸		1		100	A / V
I (Integrator Time Constant) ❹		0		10	sec
Setpoint vs. Actual T Accuracy		0.2	2	5	mV

OUTPUT, THERMOELECTRIC					
Current, peak (see SOA chart)	HTC1500 HTC3000 HTC4000	±1.4 ±2.8 ±3.9	±1.5 ±2.9 ±4.0	±1.6 ±3.0 ±4.1	Amps
Compliance Voltage ❺ Pin 11 to Pin 12	HTC1500/HTC3000 Full Temp. Range HTC4000 V+ = 5V	I _{OUT} = 500 mA I _{OUT} = 1.5 A I _{OUT} = 3.0 A I _{OUT} = 500 mA I _{OUT} = 2.0 A I _{OUT} = 4.0 A	V+ - 0.13 V+ - 0.75 V+ - 1.33 V+ - 1.2 V+ - 0.8 V+ - 1.2		Volts
Temperature Range	Temperature range depends on the physical load, sensor type, input voltage, and TE module used				
Current Limit Range ❻ (±2% FS Accuracy)	HTC1500 HTC3000 HTC4000		0-1500 0-3000 0-4000		mA
Output Power ❼	See SOA Form				

POWER SUPPLY					
Voltage, V+ ❸			5	12	V
Current, V+ supply, quiescent			200		mA

SENSORS					
Sensor Bias Current Range ❸		1μ		10m	A
Resistive Sensor Type	Thermistors, RTDs				
IC Sensor Types ❼	AD590, LM335				

- ❶ If thermistor, TEC, or laser diode are case common, the laser diode driver and temperature controller power supplies must be isolated from each other.
- ❷ Stability quoted for a typical 10 kΩ thermistor at 100 μA sensing current. Refer to [TN-TC02 : How is Temperature Stability Measured?](#) for details.
- ❸ User configurable with external resistor.
- ❹ User configurable with external capacitor.
- ❺ Compliance voltage will vary depending on power supply voltage and output current. NOTE: Compliance voltage for HTC1500/HTC3000 Revision B was limited to ±8 volts for +12V input for the HTC1500 & HTC3000.
- ❻ Output power is limited by internal power dissipation and maximum case temperature. See SOA chart to calculate internal power dissipation. Damage to the HTC will occur if case temperature exceeds 50°C.
- ❼ AD590 requires an external bias voltage and 10 kΩ resistor. Contact factory for higher voltage operation up to 30V
- ❽ Contact factory for higher voltage operation up to 30 V.

SAFETY INFORMATION

SAFE OPERATING AREA – DO NOT EXCEED INTERNAL POWER DISSIPATION LIMITS



TO ENSURE SAFE OPERATION OF THE HTC SERIES THERMOELECTRIC CONTROLLERS, IT IS IMPERATIVE THAT YOU DETERMINE THAT THE UNIT WILL BE OPERATING WITHIN THE INTERNAL HEAT DISSIPATION SAFE OPERATING AREA (SOA).

Visit the Wavelength Electronics website for the most accurate, up-to-date, and easy to use SOA calculator:

www.teamwavelength.com/support/design-tools/soa-tc-calculator/

For more information on Safe Operating Area, see our Application Note [AN-LDTC01: The Principle of the Safe Operating Area](#) and our SOA video: [How to use the Safe Operating Area \(SOA\) Calculator](#).

PREVENT DAMAGE FROM ELECTROSTATIC DISCHARGE

Before proceeding, it is critical that you take precautions to prevent electrostatic discharge (ESD) damage to the controller and your load. ESD damage can result from improper handling of sensitive electronics, and is easily preventable with simple precautions.

For more information regarding ESD, see Application Note [AN-LDTC06: Basics: Electrostatic Discharge \(ESD\)](#).

We recommend that you always observe ESD precautions when handling the HTC controller.

TERMINAL BLOCK WIRING

We recommend using a minimum of 22 AWG wire to the thermoelectric.

THEORY OF OPERATION

The HTC is a linear temperature controller that delivers bidirectional current to Peltier Effect thermoelectric coolers (TEC), or unidirectional current to resistive heaters.

The fundamental operating principle is that the controller adjusts the TEC drive current in order to change the temperature of the sensor that is connected to the thermal load. The goal is to make the voltage across the sensor match the setpoint voltage, and then keep them equal in spite of changes to ambient conditions and variations in thermal load.

The controller measures the load temperature by driving a current through the temperature sensor and measuring the voltage drop across it. It may be useful to remember that you do not directly adjust the setpoint temperature. Rather, you adjust a voltage signal that represents the sensor voltage at the desired temperature setpoint.

While the output is enabled the controller continuously compares the setpoint voltage and the actual sensor voltage. If there is a difference between the two signals the controller adjusts the output current—thereby driving the TEC or heater to change temperature—until the difference is zero.

Once the actual sensor voltage equals the setpoint voltage, the controller makes minor adjustments to the output current in order to keep the difference at zero. If the ambient temperature changes, for example, the controller will adjust the drive current accordingly.

The controller includes features that help protect the load from damage, and also make it more versatile in a wide array of applications. These features are explained in detail in **Operating Instructions — Standalone on page 7**.

- **Current limit:** Independent heating and cooling current limits avoid over-driving and damaging the TEC or heater.
- **External or Onboard temperature setpoint control:** for prototyping and benchtop applications the temperature setpoint can be adjusted with the onboard trimpot on the evaluation board. When the controller is integrated into an automated control system, the temperature setpoint can be adjusted by an external voltage signal.
- **Local Enable on HTCEVALPCB:** the controller can be configured so that the output is always on whenever power is applied to the unit.
- **Control loop:** the controller employs a smart Proportional-Integrating control loop to adjust the drive current. Both terms are user-adjustable, and when properly configured will quickly settle the load to temperature with minimal overshoot and ringing.

OPERATING INSTRUCTIONS – STANDALONE

NECESSARY EQUIPMENT

The following equipment is required to configure the HTC Series for basic operation.

- HTC Series Temperature Controller
- Digital multimeter, 4-½ digit resolution recommended
- Thermistor or other temperature sensor
- Peltier-type thermoelectric cooler or resistive heater
- Optional: test load
- Minimum 22 gauge wiring to TEC
- Power Supply (see below)
- HTCHTSK (Heatsink for HTC)
- Small flathead screwdriver

SYSTEM DESIGN DECISIONS

Before the HTC Series can be configured, several decisions must be made:

- What sensor is being used?
- What bias current is needed?
- What is the operating maximum current and maximum voltage?
- Will the system, as designed, fit within the Safe Operating Area (SOA)?

POWER SUPPLY REQUIREMENTS

The HTC Series Temperature Controller is a linear controller designed for stable, low noise operation. We recommend using a regulated, linear supply for optimum performance. Depending on your requirements, you may be able to use a switching power supply. [A switching power supply will affect noise and stability.]

The recommended operating voltage is between +5 V and +12 VDC. The voltage available to the thermoelectric or resistive heater is the “Compliance Voltage.” Compliance voltage varies with the input voltage. See Compliance Voltage section in the **Electrical Specifications — HTC Series Table**.

A heatsink is required to properly dissipate heat from the HTC mounting surface. Maximum internal power dissipation is 9 Watts and 19.5 Watts for the HTC1500/HTC3000 and the HTC4000 respectively.

GROUNDING

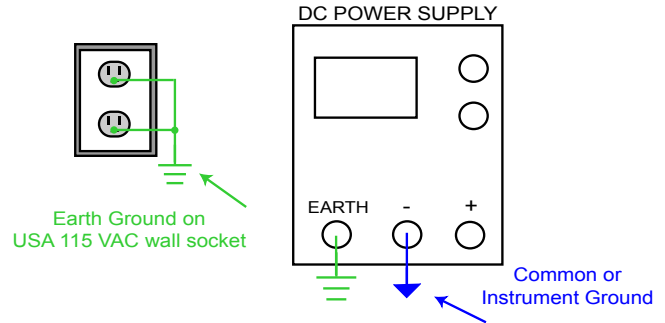

Unless Earth and Instrument Ground are connected via the power supply, Instrument Ground is floating with respect to Earth Ground

Special attention to grounding will ensure safe operation. Some manufacturers package devices with one lead of the sensor or thermoelectric connected to the metal enclosure or in the case of laser diodes, the laser anode or cathode.

WARNING: Precautions should be taken not to earth ground pins 11, 12, or 13. If any of these pins are earth grounded, then pins 5, 10, and 14 must be floating with respect to earth ground.

OPERATION WITH THERMOELECTRICS

STEP 1 Output Current Bias - Pins 2 & 3

Install a jumper for Bipolar operation or a diode for Unipolar operation. Thermistors are Negative Temperature Coefficient (NTC) sensors. Thermistor resistance decreases as temperature increases.

RTDs and IC Sensors are Positive Temperature Coefficient (PTC) sensors. A PTC sensor’s resistance increases with increasing temperature. **Figure 4** shows the installation directions.

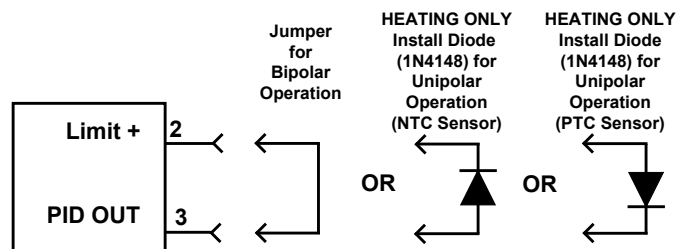

Figure 4. Sensor Installation

NOTE: Operation with Resistive Heaters can be found on page 16.

STEP 2 Limit Output Current - Pins 1 & 2

Set the heating and cooling current limits with a resistance between Pins 1 & 2. **Figure 5** shows the installation of a resistor, adjustable trimpot, or a switch. A switch can be used across this resistance to enable or disable output current. Resistor values in the tables below will set I_{LIMIT} within $\pm 5\%$ of indicated value. If greater accuracy is required for I_{LIMIT} , refer to Technical Note [TN-TC03: Setting the HTC Current Limit with Greater Precision](#).

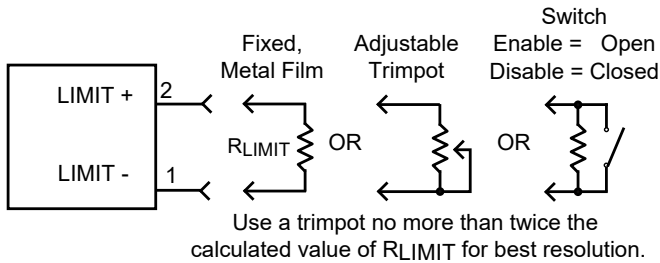

Figure 5. Resistor Installation for Limiting Output Current

HTC1500 with TEC

$$R_{LIMIT} = \frac{7864 * I_{LIMIT}}{1.8864 - 1.1796 * I_{LIMIT}}$$

I_{LIMIT}	R_{LIMIT}
0.5 A	3071 Ω
1.0 A	11.3 k Ω
1.5 A	102.1 k Ω

HTC3000 with TEC

$$R_{LIMIT} = \frac{3932 * I_{LIMIT}}{1.8864 - 0.5898 * I_{LIMIT}}$$

I_{LIMIT}	R_{LIMIT}
1.0 A	3033 Ω
2.0 A	11.1 k Ω
3.0 A	100.8 k Ω

HTC4000 with TEC

$$R_{LIMIT} = \frac{2752 * I_{LIMIT}}{1.8864 - 0.4128 * I_{LIMIT}}$$

I_{LIMIT}	R_{LIMIT}
1.0 A	1867 Ω
2.0 A	5188 Ω
3.0 A	12.7 k Ω
4.0 A	46.8 k Ω

STEP 3 Sensor Bias Current - Pins 15 & 16

Set the sensor bias current with a resistance between Pins 15 & 16.

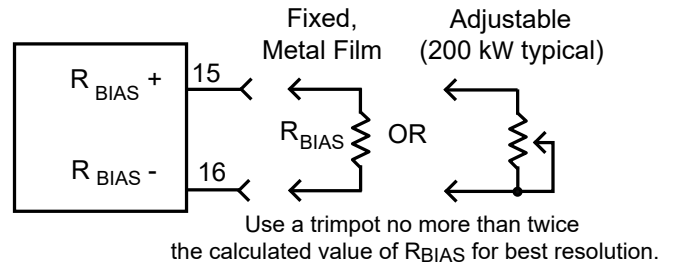

R_{BIAS} determines the bias current sourced to the sensor attached at pins 13 & 14. The chart indicates recommended currents for typical sensors. When using a voltage feedback sensor (such as an AD590), leave pins 15 & 16 open.

$$R_{BIAS} = \frac{1.225}{I_{BIAS}} - 122$$

I_{BIAS}	R_{BIAS}
10 mA	0 Ω
1 mA	1.1 k Ω
100 μ A	12.1 k Ω
10 μ A	122 k Ω

	10 μ A	100 μ A	1 mA	10 mA
10 k Ω Thermistor		X		
100 k Ω Thermistor	X			
RTD			X	X
LM335			X	

STEP 4 Sensor - Pins 13 & 14

Use virtually any type of temperature sensor with the HTC. It must produce a feedback voltage between 0.25 V and (V+ minus 1.3 V). See Step 3 (R_{BIAS}) to set the bias current to the sensor.

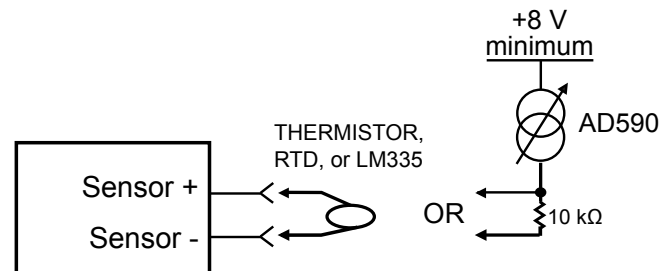

STEP 5 Proportional Gain - Pins 17 & 18

Set the gain of the system from 1 to 100 using a resistance across Pins 17 & 18. A higher proportional gain can help minimize the time to settling but may destabilize loads with long intrinsic lag times. Too low a gain may result in oscillations about setpoint. For most applications, a gain of 33 works ($R_{PROP} = 10\text{ k}\Omega$). Change the proportional gain while the output is OFF.

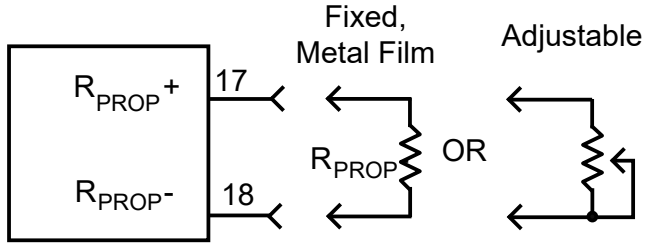

Use a trimpot no more than twice the calculated value of R_{PROP} for best resolution.

$$R_{PROP} = \frac{500\text{ k}\Omega}{GAIN} - 5\text{ k}\Omega$$

GAIN	R_{PROP}
1	495 k Ω
50	5 k Ω
100	0 Ω

STEP 6 Integrator Time Constant - Pins 19 & 20

Set the integrator time constant, C_{INT} , of the system from 0 to 10 seconds with a capacitance across Pins 19 & 20. Use a capacitor with Dissipation Factor less than 1% for best performance. These typically include metallized film polyester, polypropylene & some ceramic capacitors. Capacitors with Dissipation Factors >1% (typically electrolytic, tantalum, and ceramic) will cause drift in the Integrator circuit. To disable the integrator, use a 1 M Ω resistor across pins 19 & 20.

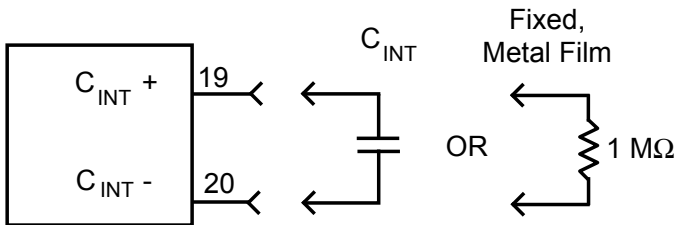

$$C_{INT} = \frac{T_{INT}}{1\text{ M}\Omega}$$

T_{INT}	C_{INT}
0 (OFF)	1 M Ω
1 second	1 μF
5 seconds	5 μF
10 seconds	10 μF

STEP 7 Temperature Setpoint - Pins 8 & 5 (Pin 4 optional)

Set the temperature setpoint apply an appropriate voltage across Pins 5 & 8 (Pin 4 optional). The controller adjusts the temperature of the load until the voltage across the temperature sensor equals the Setpoint Input voltage (pins 8 & 5). To adjust the temperature setpoint, first determine the voltage across the sensor at the target temperature; apply that same voltage across pins 8 and 5 of the controller. The diagrams show three possible configurations for setpoint voltage input.

Monitor setpoint with a DVM at pins 7 & 5, or actual sensor voltage across pins 6 & 5.

Example: Desired Temperature: 25°C
 Sensor: 10 k Ω thermistor Resistance at 25°C: 10 k Ω
 Bias Current: 100 μA $V_{SET} = 10\text{ k}\Omega * 100\text{ }\mu\text{A} = 1\text{ V}$

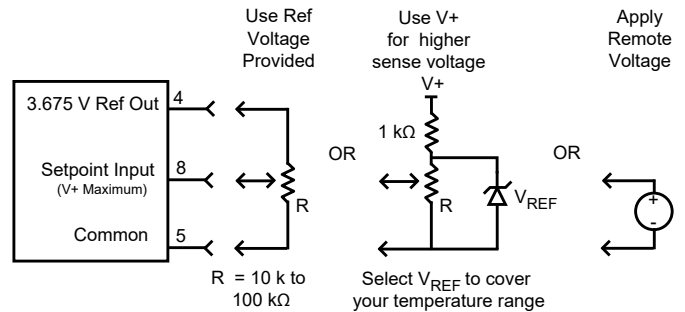

STEP 8 TEC & Output Current Measurement - Pins 11 & 12

Wire the TEC to Pins 11 & 12. Use an ammeter if you want to monitor TEC current. Current flows from positive to negative when the HTC is cooling with an NTC temperature sensor. When using an LM335, AD590, RTD, or other PTC sensor, reverse the polarity of the leads (i.e. connect the positive lead of the TEC module to TEC- and the negative lead of the TEC module to TEC+).

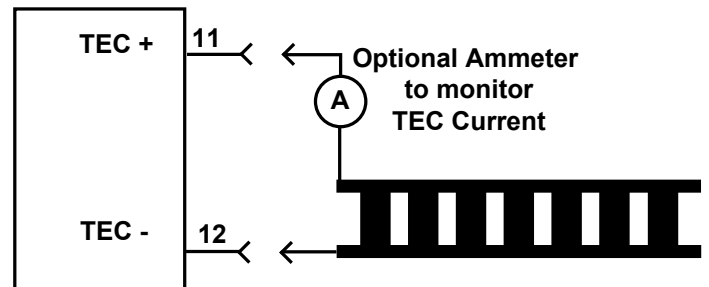

OPERATION INSTRUCTIONS – WITH EVALUATION BOARD

HTC SERIES WITH HTCEVALPCB

Operate the HTC Series quickly using the HTCEVALPCB. See **page 14** for mounting instructions

NECESSARY EQUIPMENT

The equipment is the same as on **page 7** with the addition of the HTCEVALPCB board.

SYSTEM DESIGN DECISIONS

Before the HTC Series can be configured, several decisions must be made:

- What sensor is being used?
- What bias current is needed?
- What is the operating maximum current and maximum voltage?
- Will the system, as designed, fit within the Safe Operating Area (SOA)?

STEP I INSTALL HTC ON THE HTCEVALPCB WITH HTC HEATSINK

1. Feed the HTC pins through the large opening in the Evaluation board so that the HTC pins are on the top side of the Evaluation board and the mounting tabs are against the back side of the board. NOTE: If your application requires the pins to be bent, clamp the pins between the HTC housing and the bend to avoid damage to the HTC.
2. Line up the heatsink holes behind the HTC and insert the screws through the Evaluation board and HTC unit into the tapped heatsink holes.
3. Line up the HTC pins on the solder pads on the Evaluation board and tighten the screws.
4. Solder the HTC pins to the solder pads. NOTE: Do not exceed 700°F soldering temperature for more than 5 seconds on any pin.
5. If you are using a PCB that is not 0.062" thick, consider the other HTC models for 0.031" boards.

See **additional technical information on page 14** for further details.

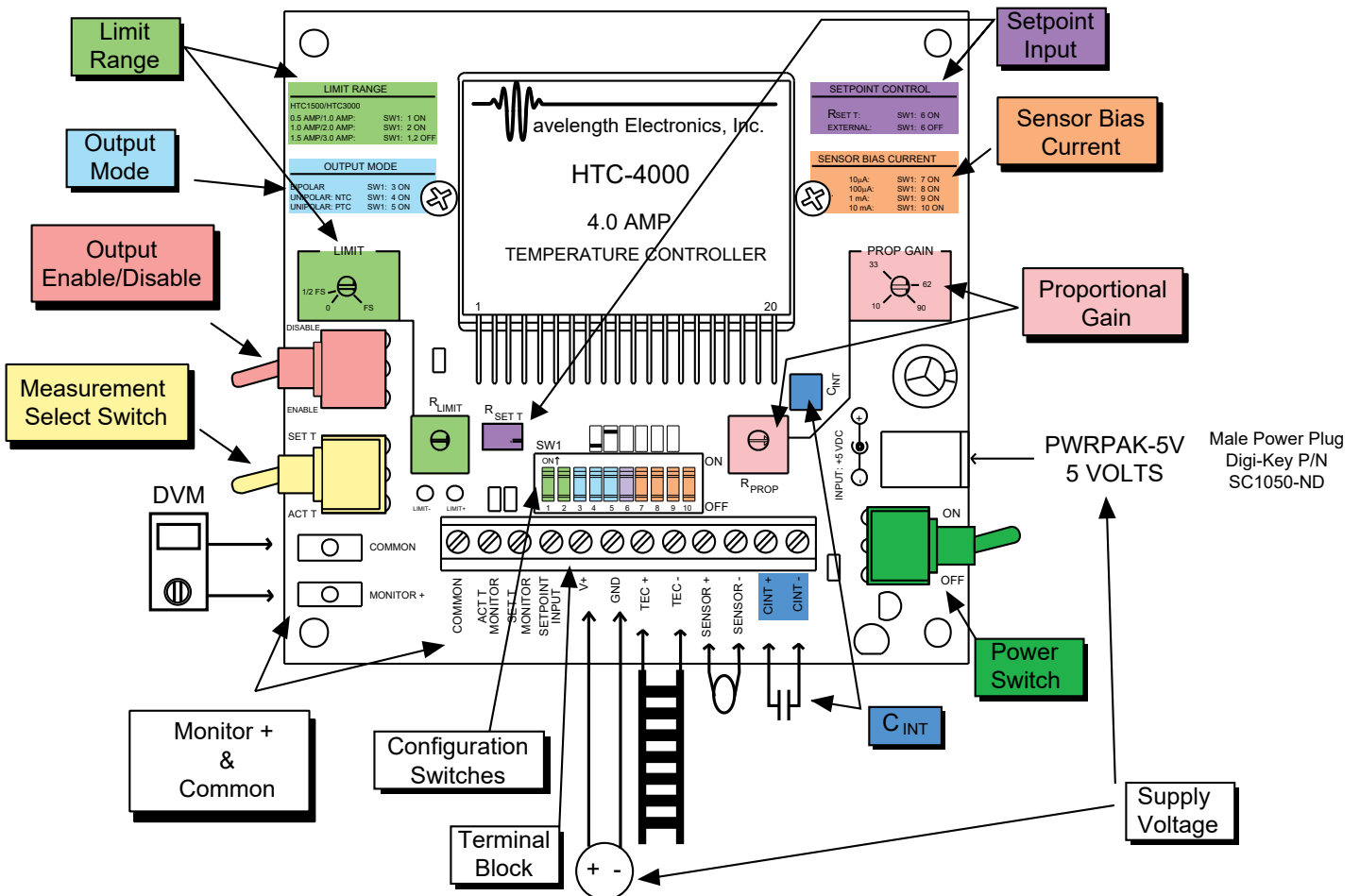

Figure 6. HTCEVALPCB Board Top View

STEP 2 CONFIGURE THE SWITCHES

Set the Current Limit Range, Output Mode, Setpoint Input, and the Sensor Bias Current by using the 10 DIP switches on Switch 1, the Configuration Switches. See **Table 2 on page 12** for more details of the HTCEVALPCB DIP switches settings. **Figure 6** shows the location of the Configuration Switches as well other toggle switches for Output Enable/Disable, Measurement Select, and Power. It also shows the locations for the Limit Range, Setpoint Input, Proportional Gain, and Integrator Time Constant capacitors and trimpots.

Use the Power Switch to enable or disable the power to the EVAL board. Connect a power supply by either the PWRPAK-5V input connector or the terminal block connections V+ and GND.

Enable or disable output current by using the Output Enable/Disable switch.

Change the measurement you are monitoring, when a voltmeter is connected to COMMON and MONITOR+, by using the Measurement Select Switch. This will toggle the measurement from ACT T and SET T.

STEP 3 SET THE PROPORTIONAL GAIN

Adjust the PROP GAIN trimpot to change the proportional gain of your system. The factory default is 33. Values can range from 10 to 90 on the EVAL board.

STEP 4 SET THE LIMIT RANGE

Turn R_{LIMIT} trimpot fully clockwise to full-scale for best results while using the current limit switches. Switch settings can be found in **Table 2**.

STEP 5 SET THE INTEGRATOR TIME CONSTANT

Add capacitance across the C_{INT+} and C_{INT-} inputs on the terminal block to increase the integrator time constant. A 1 μ F capacitor is mounted on the EVAL board and gives one second integrator time constant.

STEP 6 SET THE SETPOINT INPUT

Adjust the onboard R_{SETT} trimpot or use an external/remote input voltage on the terminal block (SETPOINT INPUT) to control the temperature setpoint. Be sure SW1:6 is set to the proper setting.

Refer to **Table 2** for all HTCEVALPCB setting and configurations and **Table 3** for HTCEVALPCB terminal block function (TEC, Sensor, CINT, and alternate Power connections).

HTCEVALPCB SETTINGS AND OPERATION

Table 2. HTCEVALPCB SETTINGS

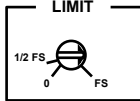
SILKSCREEN LABEL	NAME	FUNCTION																																				
SW1	Configuration Switch	<p>The Configuration Switch selects the OUTPUT MODE, LIMIT RANGE, SETPOINT INPUT, and SENSOR BIAS CURRENT. Before applying voltage to the HTCEVALPCB, check the switch settings for proper configuration.</p>  <p>The FACTORY DEFAULT settings are: Limit Range: Lowest (SW1:1 ON, SW1:2 OFF) Bipolar Operation: (SW1:3 ON, SW1:4 & 5 OFF) Onboard Trimpot Control: (SW1:6 ON) 100µA Sensor Bias Current: (SW1:7, 9, & 10 OFF, SW1:8 ON)</p> <p>The following details how to choose the switch settings.</p>																																				
R _{LIMIT}	Limit Range SW Positions 1 & 2	 <p>For best results, set R_{LIMIT} trimpot fully clockwise (full-scale) and use current limit switches. Switch positions 1 & 2 set the “full scale” value to one of three current ranges. Select a range that includes your maximum operating current:</p> <table border="1"> <thead> <tr> <th>HTC1500</th> <th>HTC3000</th> <th>HTC4000</th> <th>SW1:1</th> <th>SW1:2</th> </tr> </thead> <tbody> <tr> <td>0 - 0.5 A</td> <td>0 - 1.0 A</td> <td>0 - 1.5 A</td> <td>ON</td> <td>OFF</td> </tr> <tr> <td>0 - 1.0 A</td> <td>0 - 2.0 A</td> <td>0 - 3.0 A</td> <td>OFF</td> <td>ON</td> </tr> <tr> <td>0 - 1.5 A</td> <td>0 - 3.0 A</td> <td>0 - 4.0 A</td> <td>OFF</td> <td>OFF</td> </tr> </tbody> </table> <p>If you want to accurately measure the output current to the TEC, connect an ammeter in series with the TEC as described on page 11, step 8 of the datasheet.</p>	HTC1500	HTC3000	HTC4000	SW1:1	SW1:2	0 - 0.5 A	0 - 1.0 A	0 - 1.5 A	ON	OFF	0 - 1.0 A	0 - 2.0 A	0 - 3.0 A	OFF	ON	0 - 1.5 A	0 - 3.0 A	0 - 4.0 A	OFF	OFF																
HTC1500	HTC3000	HTC4000	SW1:1	SW1:2																																		
0 - 0.5 A	0 - 1.0 A	0 - 1.5 A	ON	OFF																																		
0 - 1.0 A	0 - 2.0 A	0 - 3.0 A	OFF	ON																																		
0 - 1.5 A	0 - 3.0 A	0 - 4.0 A	OFF	OFF																																		
OUTPUT MODE	Output Mode SW Positions 3, 4, 5	<p>The HTCEVALPCB can be set to operate the HTC controllers in bipolar (TEC) or unipolar (heater) operation. Configure the switches for Bipolar NTC/PTC operation.</p> <table border="1"> <thead> <tr> <th>OUTPUT BIAS</th> <th>SW1:3</th> <th>SW1:4</th> <th>SW1:5</th> </tr> </thead> <tbody> <tr> <td>Bipolar NTC/PTC</td> <td>ON</td> <td>OFF</td> <td>OFF</td> </tr> <tr> <td>Heating, Unipolar: NTC</td> <td>OFF</td> <td>ON</td> <td>OFF</td> </tr> <tr> <td>Heating, Unipolar, PTC</td> <td>OFF</td> <td>OFF</td> <td>ON</td> </tr> </tbody> </table>	OUTPUT BIAS	SW1:3	SW1:4	SW1:5	Bipolar NTC/PTC	ON	OFF	OFF	Heating, Unipolar: NTC	OFF	ON	OFF	Heating, Unipolar, PTC	OFF	OFF	ON																				
OUTPUT BIAS	SW1:3	SW1:4	SW1:5																																			
Bipolar NTC/PTC	ON	OFF	OFF																																			
Heating, Unipolar: NTC	OFF	ON	OFF																																			
Heating, Unipolar, PTC	OFF	OFF	ON																																			
R _{SET T}	Setpoint Input SW Position 6	<p>The temperature setpoint can be controlled by the onboard R_{SET T} trimpot or with an external input voltage on the terminal block (SETPOINT INPUT). Switch position 6 determines how the setpoint is controlled. This table is labeled on the HTCPEVALPCB as “SETPOINT CONTROL.”</p> <table border="1"> <thead> <tr> <th>TEMPERATURE SETPOINT</th> <th>SW1:6</th> </tr> </thead> <tbody> <tr> <td>Onboard R_{SET T} Trimpot</td> <td>ON</td> </tr> <tr> <td>Remote SETPOINT INPUT</td> <td>OFF</td> </tr> </tbody> </table>	TEMPERATURE SETPOINT	SW1:6	Onboard R _{SET T} Trimpot	ON	Remote SETPOINT INPUT	OFF																														
TEMPERATURE SETPOINT	SW1:6																																					
Onboard R _{SET T} Trimpot	ON																																					
Remote SETPOINT INPUT	OFF																																					
SENSOR BIAS CURRENT (table)	Sensor Bias Table Configurations SW Positions 7, 8, 9, 10	<p>Choosing the correct bias current for your sensor is important. Based on the resistance vs. temperature characteristics of your sensor, select a bias current that gives you a voltage feedback between 0.25 V and (V+ minus 1.3 V).</p> <table border="1"> <thead> <tr> <th>BIAS CURRENT</th> <th>SW1:7</th> <th>SW1:8</th> <th>SW1:9</th> <th>SW1:10</th> <th>RECOMMENDED FOR:</th> </tr> </thead> <tbody> <tr> <td>10 µA</td> <td>ON</td> <td>OFF</td> <td>OFF</td> <td>OFF</td> <td>100 kΩ Thermistors</td> </tr> <tr> <td>100 µA</td> <td>OFF</td> <td>ON</td> <td>OFF</td> <td>OFF</td> <td>10 kΩ Thermistors</td> </tr> <tr> <td>1 mA</td> <td>OFF</td> <td>OFF</td> <td>ON</td> <td>OFF</td> <td>1 kΩ RTDs & LM335 IC Sensor</td> </tr> <tr> <td>10 mA</td> <td>OFF</td> <td>OFF</td> <td>OFF</td> <td>ON</td> <td>100 Ω RTDs</td> </tr> <tr> <td>0 mA</td> <td>OFF</td> <td>OFF</td> <td>OFF</td> <td>OFF</td> <td>AD590</td> </tr> </tbody> </table>	BIAS CURRENT	SW1:7	SW1:8	SW1:9	SW1:10	RECOMMENDED FOR:	10 µA	ON	OFF	OFF	OFF	100 kΩ Thermistors	100 µA	OFF	ON	OFF	OFF	10 kΩ Thermistors	1 mA	OFF	OFF	ON	OFF	1 kΩ RTDs & LM335 IC Sensor	10 mA	OFF	OFF	OFF	ON	100 Ω RTDs	0 mA	OFF	OFF	OFF	OFF	AD590
BIAS CURRENT	SW1:7	SW1:8	SW1:9	SW1:10	RECOMMENDED FOR:																																	
10 µA	ON	OFF	OFF	OFF	100 kΩ Thermistors																																	
100 µA	OFF	ON	OFF	OFF	10 kΩ Thermistors																																	
1 mA	OFF	OFF	ON	OFF	1 kΩ RTDs & LM335 IC Sensor																																	
10 mA	OFF	OFF	OFF	ON	100 Ω RTDs																																	
0 mA	OFF	OFF	OFF	OFF	AD590																																	

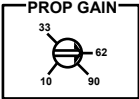
SILKSCREEN LABEL	NAME	FUNCTION
R _{PROP}	Proportional Gain	 <p>Begin with a proportional gain of 33 (factory default). The temperature vs. time response of your system can be optimized for overshoot and settling time by adjusting the R_{PROP} trimpot between 10 and 90. Increasing the gain will dampen the output (longer settling time, less overshoot). For more information on PID controllers, see Technical Note TN-TC01-Optimizing Thermoelectric Temperature Control Systems</p>
Power Switch (ON/OFF)	Power Switch	This switch enables or disables the DC voltage from either the PWRPAK-5V input connector or the terminal block connections labeled V+ and GND. The green LED will light when power is applied to the HTCEVALPCB and the switch is "ON." USE ONLY ONE INPUT to supply power to the HTCEVALPCB.
Output Switch	Output Switch	The output current is enabled or disabled by toggling this switch.
Select Switch	Monitor SET T or ACT T	With a DVM connected to MONITOR + and COMMON, toggle the Measurement Select Switch to measure SET T (setpoint temperature) or ACT T (actual temperature). Alternatively, SET T and ACT T can be measured via the ACT T and SET T MONITORS (referenced to COMMON) on the terminal block (positions 1, 2, and 3).
C _{INT}	Integrator Time Constant Capacitor	A 1 μF capacitor is mounted on the PCB, as shown on page 18 , and will give you a one second integrator time constant. By adding capacitance across the C _{INT+} and C _{INT-} inputs on the terminal block, you can increase the integrator time constant. See STEP 6 Integrator Time Constant - Pins 19 & 20 on page 9 for more information. Use only capacitors with a dissipation factor less than 1%. For more information on PID controllers, see Technical Note TN-TC01-Optimizing Thermoelectric Temperature Control Systems

TERMINAL BLOCK POSITIONS – HTCEVALPCB

Wire your thermoelectric module and sensor via the 12-contact screw terminal connector. Connect the external setpoint voltage input here, also. Other signals are available on the PCB as well as on the terminal block: Actual and Setpoint monitors, Integrator Time Constant Capacitor, and Supply Voltage.

Table 3. HTCEVALPCB Terminal Block Function

SILKSCREEN LABEL	NAME	POSITION DESCRIPTION
Common	Common Ground	Ground reference for control signals
ACT T MONITOR	Actual Temperature Monitor	Measure/Monitor actual temperature with voltmeter
SET T MONITOR	SET T MONITOR	Measure temperature setpoint with voltmeter
SETPOINT INPUT	SETPOINT INPUT	Temperature setpoint can be controlled with an external input voltage (see R _{SET T} in table above).
V+	Voltage Supply	Alternative to PWRPAK-5V input connector (labeled INPUT:+5VDC) is terminal block connections labeled V+ and GND). USE ONLY ONE INPUT to supply power to the HTCEVALPCB.
GND	Power Ground	Power Supply Ground
TEC + TEC -	Thermoelectric Connections	TEC+ & TEC- supply current to the TEC. With NTC sensors, connect TEC+ to positive lead of TEC. With PTC sensors, connect TEC- to positive lead of TEC.
SENSOR + SENSOR-	Sensor Connections	A sensor bias current will source from Sensor+ to Sensor- if a resistor is tied across.
CINT + CINT -	Integrator Time Constant Capacitance	CINT sets the integral time constant of the system from 0 to 10 seconds (see STEP 6 on page 9 for specifications for capacitance).

SIZE (H X W X D) 0.34" x 2.65" x 1.6" [8.6 x 67 x 41 mm]	WEIGHT < 1.5 oz.	CONNECTORS 20 pin header, 0.1" spacing	REQUIRED HEATSINK CAPACITY 5.6 °C / W / 3 in	WARM-UP 1 hour to rated accuracy
---	----------------------------	--	--	--

ADDITIONAL TECHNICAL INFORMATION

HTC SERIES: PCB & HEATSINK MOUNTING

To mount the HTC Series to the heatsink and optional evaluation PCB, refer to the drawings and instructions below:

MOUNTING INSTRUCTIONS

Begin by applying thermal grease (**Figure 7**) to the back of the HTC to ensure good thermal contact. We recommend Wavelength Electronics part number THERM-PST.



Figure 7. Thermal Grease

1. Feed the HTC pins through the large opening in the Evaluation board so that the HTC pins are on the top side of the Evaluation board and the mounting tabs are against the back side of the board.
2. Line up the heatsink holes behind the HTC and insert the screws through the Evaluation board and HTC unit into the tapped heatsink holes.
3. Line up the HTC pins on the solder pads on the Evaluation board and tighten the screws.
4. Solder the HTC pins to the solder pads. NOTE: Do not exceed 700°F soldering temperature for more than 5 seconds on any pin.

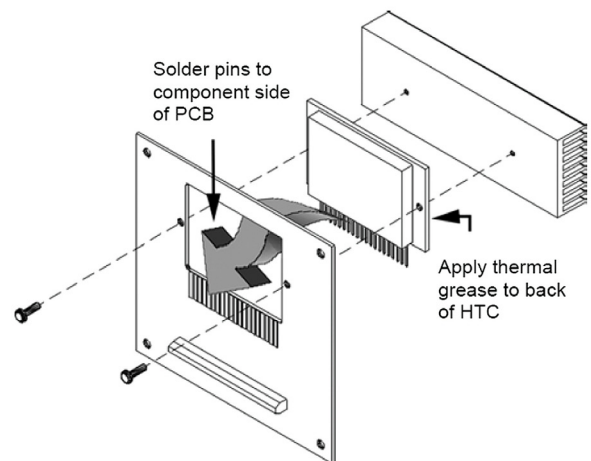

Figure 8. HTC Series, HTCEVALPCB, and Heatsink Mounting

Figure 8 shows this process.

If the HTC is to be used without the HTCEVALPCB board, apply the thermal grease as directed, line up the screw holes in the HTC and heatsink and attach with the supplied screws as shown in **Figure 9**. Connect the HTC pins to your system by soldering them to the appropriate leads.

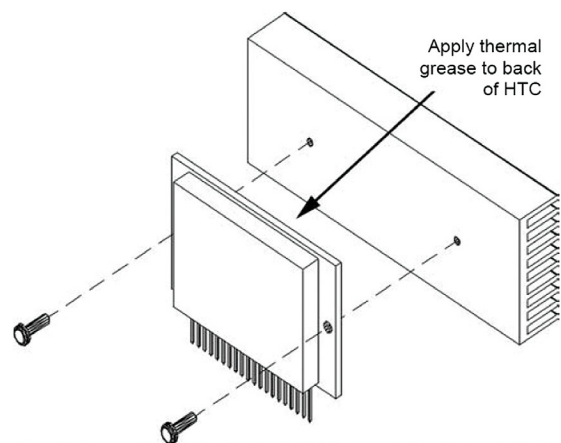
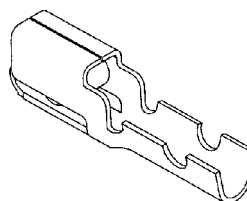
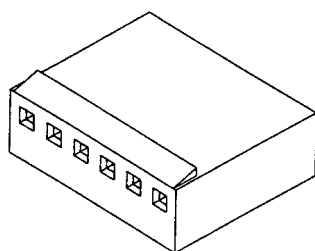

Figure 9. HTC Series and Heatsink Mounting

USING A CONNECTOR WITH THE HTC

The HTC leads are meant to be soldered onto a circuit board. If you want to use a connector, we recommend the following:

Qty	Description	Molex Part Number
1	Molex Crimp Terminal Housing 20 pin (High Pressure)	10-11-2203
20	Molex Crimp Terminal 7879 (High Pressure)	08-55-0129



Molex Crimp Terminal Housing 20 Pin (High Pressure)
(only 6 pins shown)

Molex Crimp Terminal 7879 (High Pressure)
for wire size 22 - 30 AWG, Select Gold Plating

20 pin Molex Part Number: **10-11-2203**
L x W = 2.02" x 0.51" (51.3 mm x 12.9 mm)

Molex Part Number: **08-55-0129**
L x W = 0.44" x 0.76" (11.2 mm x 1.93 mm)

REVISION HISTORY NOTES - HTC1500 & HTC3000

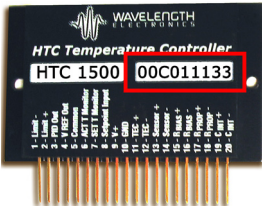
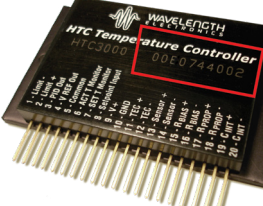
CHANGE:	REVISION B	REVISIONS C & D (APRIL & JULY 2004)	REVISION E (JULY 2009)
Lot # Location (third digit indicates Revision)			
Efficiency Increase: Compliance Voltage	V+ minus 3 to 4 V		V+ minus 0.13 to 2.3 V
Setpoint vs. Actual accuracy	10%	5 mV	
Improved stability of Reference Voltage (Pin 4)			15ppm (typical)
Temperature Stability 1-hour OFF ambient 1-hour ON ambient 24-hour OFF ambient			0.0009°C 0.002°C 0.0015°C

OPERATION WITH RESISTIVE HEATERS

Operating the HTC with resistive heaters is very similar to operating the HTC with thermoelectric modules. Use low resistance heaters (< 25 Ω) for maximum power output. Resistances greater than 100 Ω may limit the output voltage, and therefore power, slowing down temperature changes.

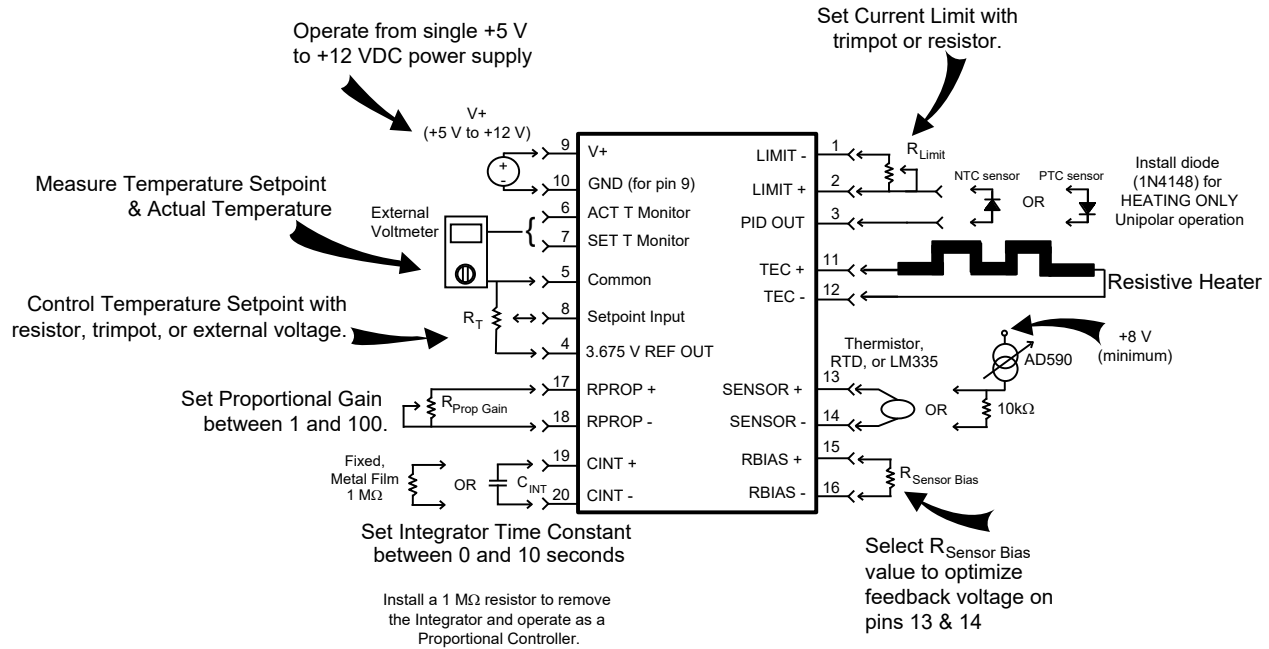

Follow the operating instructions for thermoelectrics on **page 7-11**, but with these important changes to the following steps:

STEP 1: Depending on your selection of NTC or PTC sensor, attach a blocking diode as shown in **STEP 1 on page 7**.
OPERATING THE HTC IN BIPOLAR MODE WITH RESISTIVE HEATERS WILL RESULT IN THERMAL RUNAWAY, AND MAY DAMAGE THE LOAD.

STEP 2: The output current maximum is reduced to 1 A with the HTC1500 and 2 A with the HTC3000. Calculate the LIMIT output resistance with these equations:

$$\text{HTC1500} \quad R_{\text{LIMIT}} = \frac{20 \text{ k}\Omega}{\frac{3.0625}{I_{\text{LIMIT}}} - 3}$$

$$\text{HTC3000} \quad R_{\text{LIMIT}} = \frac{20 \text{ kW}}{\frac{6.125}{I_{\text{LIMIT}}} - 3}$$

STEP 8: Attach the resistive heater to Pins 11 & 12 (TEC+ & TEC-).

RESISTIVE HEATER VOLTAGE VS. CURRENT FOR HTC3000 REVISION C & LATER (25°C AMBIENT)

HEATER RESISTANCE (OHMS)	V _S = 5 V		V _S = 12 V	
	COMPLIANCE (VOLTS)	MAX CURRENT (AMPS)	COMPLIANCE (VOLTS)	MAX CURRENT (AMPS)
2	4.18	1.93	-	-
3	4.45	1.36	-	-
4	4.57	1.10	-	-
5	4.59	0.85	-	-
6	4.60	0.74	11.44	1.80
7	4.65	0.64	11.47	1.58
8	4.69	0.57	11.56	1.40
10	4.70	0.48	11.70	1.15
11	4.72	0.43	11.74	1.06
12	4.73	0.39	11.82	0.98
14	4.76	0.34	11.88	0.84
16	4.80	0.30	11.94	0.74
18	4.82	0.27	11.97	0.66

SAFE OPERATING AREA

The Safe Operating Area of the HTC controller is determined by the amount of power that can be dissipated within the output stage of the controller. If that power limit is exceeded permanent damage can result.



DO NOT EXCEED THE SAFE OPERATING AREA (SOA). EXCEEDING THE SOA VOIDS THE WARRANTY.

Refer to the Wavelength Electronics website for the most up-to-date SOA calculator for our products. The online tool is fast and easy to use, and also takes into consideration operating temperature.

www.teamwavelength.com/support/design-tools/soa-tc-calculator/

SOA charts are included in this datasheet for quick reference, however we recommend you use the online tools instead. See our SOA video: [How to use the Safe Operating Area \(SOA\) Calculator](#).

An example SOA calculation for the HTC1500 & HTC3000 with heatsink is shown in **Figure 10** where:

$V_{+} = 12$ Volts (Point C) $V_{LOAD} = 5$ Volts
 $I_{LOAD} = 1$ Amp (Point B) $V_{DROP} = 12 - 5 = 7$ Volts (Point A)

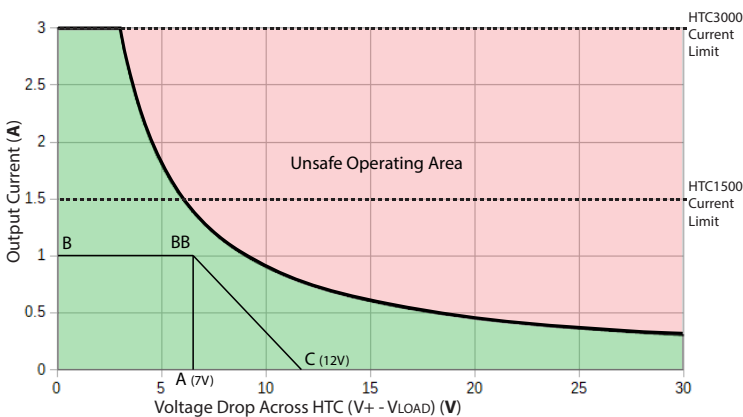

Figure 10. HTC1500 & HTC3000 SOA

Follow these steps to determine if the controller will be operating within the SOA.

- Refer to the thermoelectric datasheet to find the maximum voltage (V_{LOAD}) and current (I_{LOAD}) specifications
- Calculate the voltage drop across the controller:
 $V_{DROP} = V_{+} - V_{LOAD}$ (V_{+} is the power supply voltage)
- Mark V_{DROP} on the X-axis, and extend a line upward
- Mark I_{LOAD} on the Y-axis, and extend a line (Line BB) to the right until it intersects the V_{DROP} line
- On the X-axis, mark the value of V_{+}
- Extend a diagonal line from V_{+} to the intersection of the V_{DROP} and I_{LOAD} lines; this is the Load Line
- If the Load Line crosses the Safe Operating Area line at any point, the configuration is not safe

If the SOA Calculator indicates the HTC will be outside of the Safe Operating Area, the system must be changed so that less power is dissipated within the controller. See Wavelength Electronics Application Note [AN-LDTC01: The Principle of the Safe Operating Area](#) for information on shifting the Load Line.

An example SOA calculation for the HTC4000-62 with heatsink is shown in **Figure 11** where:

$V_{+} = 12$ Volts (Point C) $V_{LOAD} = 7$ Volts
 $I_{LOAD} = 3$ Amp (Point B) $V_{DROP} = 12 - 7 = 5$ Volts (Point A)

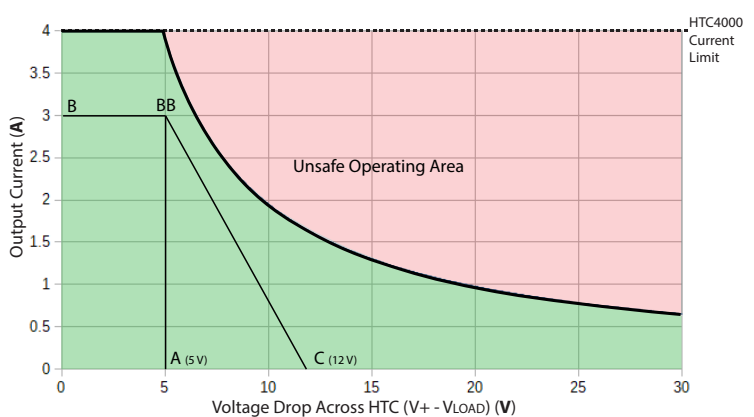
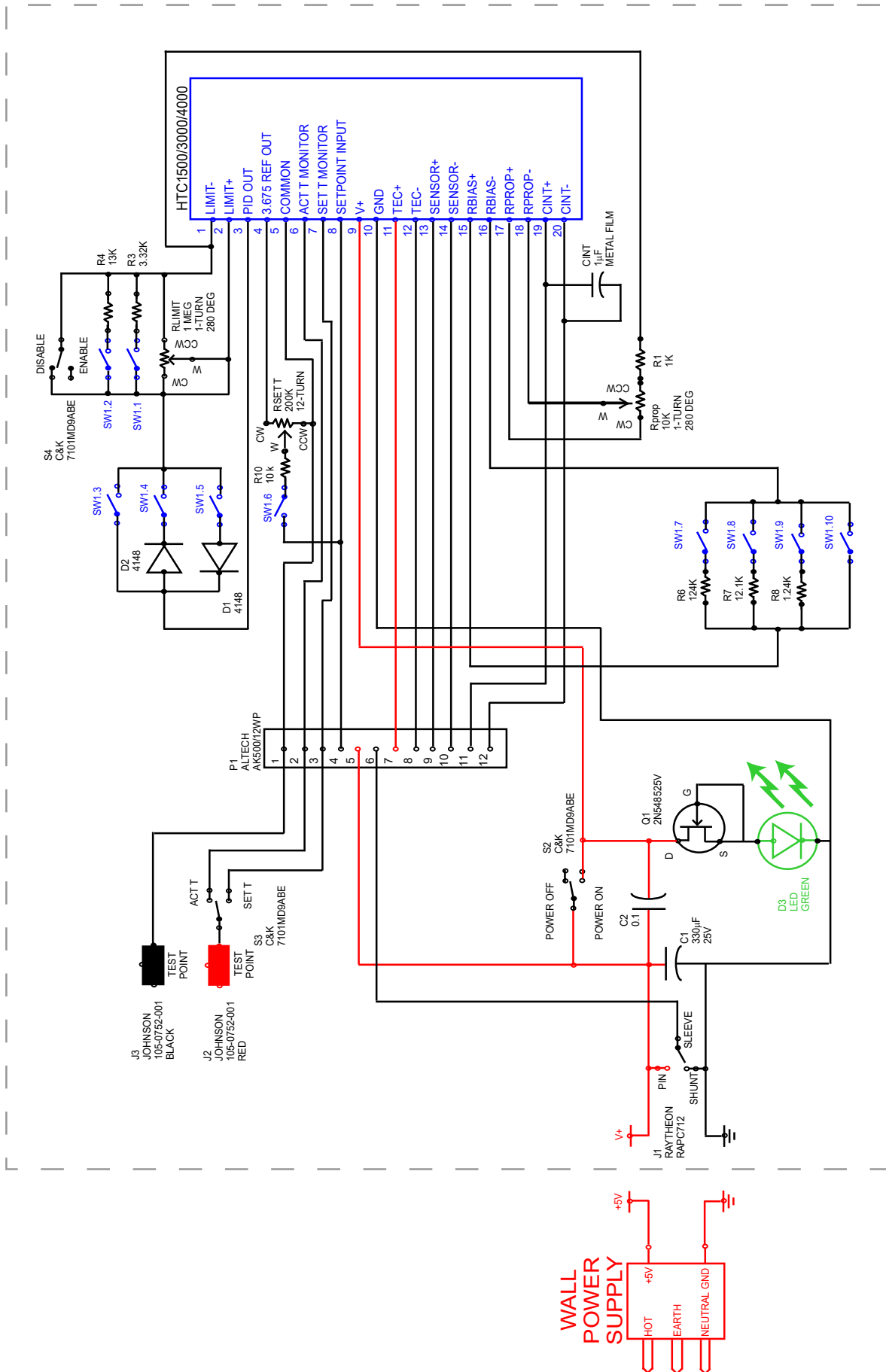

Figure 11. HTC4000-62 SOA

HTC EVALUATION BOARD SCHEMATIC

HTC EVALUATION BOARD



TROUBLESHOOTING

PROBLEM	POTENTIAL CAUSES	SOLUTIONS
Temperature is decreasing when it should be increasing -OR- Temperature is increasing when it should be decreasing	The TEC may be connected backwards to the HTC	The convention is that the red wire on the TEC module connects to TEC+ (Pin 11) and the black wire to TEC- (Pin 12). If your TEC is connected in this manner and the problem persists, the TEC module itself may be wired in reverse. Switch off power to the system, reverse the connections to the HTC, and then try again to operate the system. TEC wiring polarity is dependent on the temperature sensor type (NTC vs. PTC). Verify that the polarity is correct for the sensor type you are using (see Table 1 on page 4).
Temperature increases beyond setpoint and will not come down	The heatsink may be inadequately sized to dissipate the heat from the load and the TEC module, and now the system is in thermal runaway	Increase the size of the heatsink, add a fan to blow air over the heatsink, and/or reduce the ambient air temperature around the heatsink.
	The TEC and heatsink are not adequately sized for the thermal load	The heat being generated by the load may be too great for the TEC to pump to the heatsink; a larger TEC may be needed. Consult our Technical Note TN-TC01: Optimizing Thermoelectric Temperature Control Systems and Application Note AN-TC09: Specifying Thermoelectric Coolers .
Temperature does not stabilize very well at the setpoint	There may be poor thermal contact between components of the thermal load	Use thermal paste or washers between the load / TEC and the TEC / heatsink interfaces. Ensure the temperature sensor is in good thermal contact with the load.
	Unit may be operating outside the ideal region of the temperature sensor	The sensor type and bias current should be selected to maximize sensitivity at the target temperature. Thermistors provide the best performance, particularly for applications where a single setpoint temperature must be accurately maintained. For example, at 25°C a 10 kΩ thermistor has a sensitivity of 43 mV / °C, whereas an RTD sensor has a sensitivity of 4 mV / °C.
	Proportional control term may be set too high	Reduce the value of the proportional term. For more information, reference our Technical Note TN-TC01: Optimizing Thermoelectric Temperature Control Systems .
	Heatsink may not be sized correctly or may not have adequate airflow	Ambient temperature disturbances can pass through the heatsink and thermoelectric and affect the device temperature stability. Choosing a heatsink with a larger mass and lower thermal resistance will improve temperature stability. Adding a fan across the thermoelectric's heatsink may be required.
Temperature does not reach the setpoint	Current driven to the TEC or heater may be insufficient	Increase the current limit – but DO NOT exceed the specifications of the TEC or heater.
	The controller may not have sufficient compliance voltage to drive the TEC or heater	Increase the power supply voltage; be certain to verify that the controller is within the Safe Operating Area with Wavelength's Temperature Controller SOA calculator: www.teamwavelength.com/support/design-tools/soa-tc-calculator/
	The sensor may not have good contact with the heatsink and load	Use thermal paste or washers between the load / TEC and the TEC / heatsink interfaces. Contact the thermoelectric manufacturer for their recommended mounting methods.
The HTCEVALPCB is not producing current	Improperly configured Power Switch or Output Enable/Disable Switch	Make sure that the Power switch is set to the ON position and the Output Enable/Disable switch is set to the ENABLE position.
	The Limit Range may be turned all the way counter clockwise (CCW)	For best results, turn the Limit Range trimpot fully clockwise (full-scale) and use the table for current limit switch positions.

TROUBLESHOOTING CONTINUED

<p>Temperature is slow to stabilize and is not within the specifications with Resistive Heaters</p>	<p>Setpoint temperature is set close to the ambient temperature</p>	<p>Set the temperature at least 10°C above ambient when using a resistive heater. A resistive heater is unable to precisely maintain temperatures near ambient. Once the temperature overshoots the setpoint, the controller turns off and relies on ambient temperature to cool the load. If setting the temperature 10°C or more above ambient is not possible, then choose a thermoelectric controller, which can alternately heat and cool the load to maintain a more precise setpoint temperature.</p>
<p>Overshoot with Small Loads</p>	<p>The I Term may be too large</p>	<p>With small, fast loads, the HTC has a tendency to overshoot by up to 10°C. This problem is caused by overcompensation by the integrator.</p> <p>Decrease the I TERM by lowering the capacitance across C_{INT+} and C_{INT-} or only using the factory default C_{INT} 1 μF capacitor mounted on the board.</p>

MECHANICAL SPECIFICATIONS

All Tolerances are $\pm 5\%$

TOP VIEW (All models)

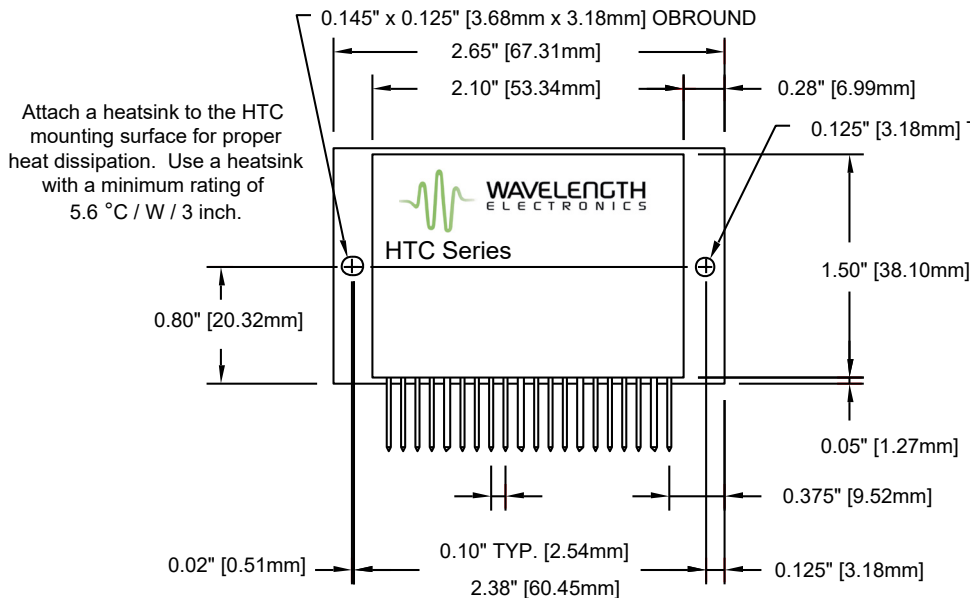

SIDE VIEW (HTC1500 & HTC3000)

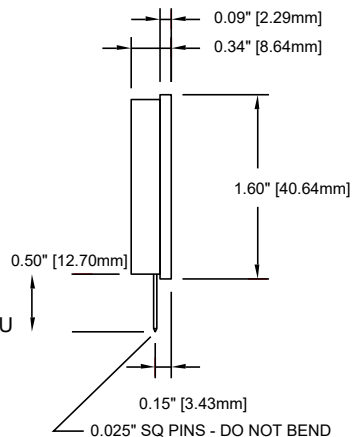

SIDE VIEW (HTC1500-62 & HTC3000-62 & HTC4000-62)

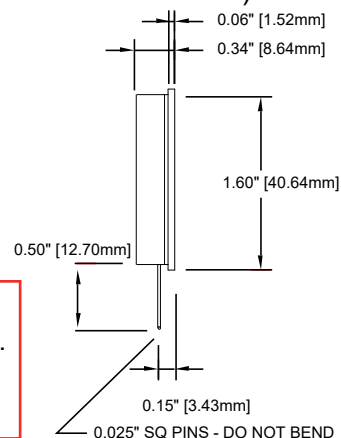

The HTCEVALPCB board is 0.062" thick.
 Use HTC1500-62 or HTC3000-62 or HTC4000-62 when using 0.062" thick boards.
 Use HTC1500 or HTC3000 when using 0.031" thick boards.

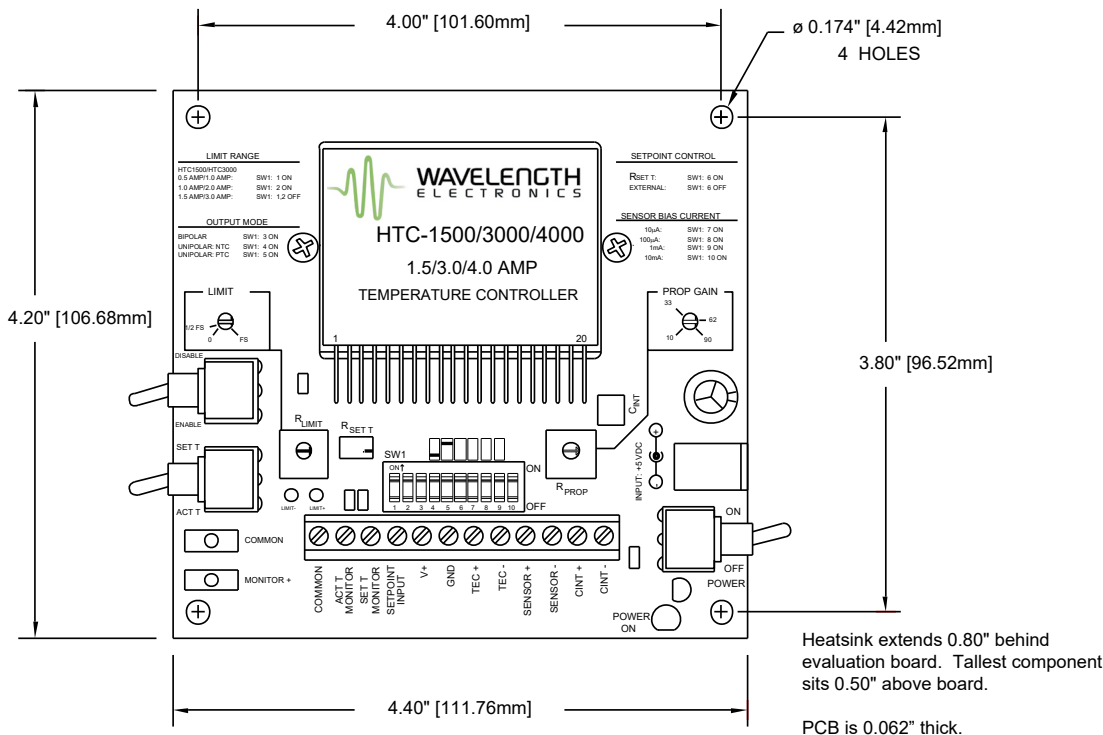

MECHANICAL SPECIFICATIONS – HEATSINK

Wavelength Electronics P/N HTCHTSK shown.

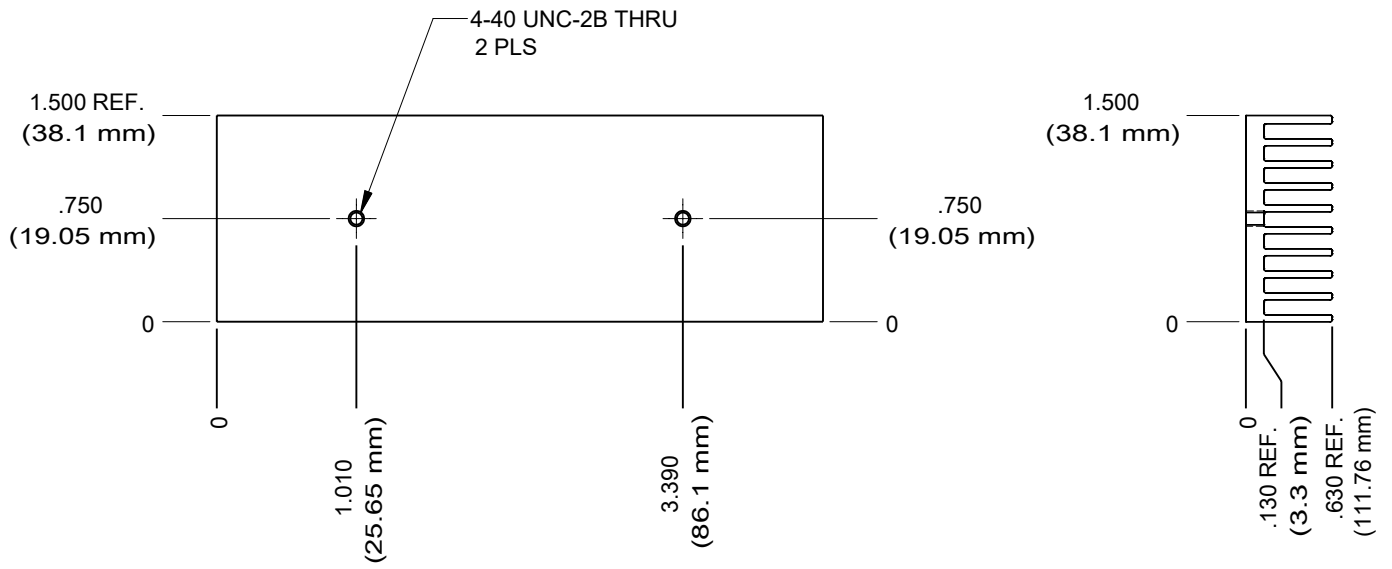

All Tolerances are $\pm 5\%$

CERTIFICATION AND WARRANTY

CERTIFICATION

Wavelength Electronics, Inc. (Wavelength) certifies that this product met its published specifications at the time of shipment. Wavelength further certifies that its calibration measurements are traceable to the United States National Institute of Standards and Technology, to the extent allowed by that organization’s calibration facilities, and to the calibration facilities of other International Standards Organization members.

WARRANTY

This Wavelength product is warranted against defects in materials and workmanship for a period of one (1) year from date of shipment. During the warranty period, Wavelength will, at its option, either repair or replace products which prove to be defective.

WARRANTY SERVICE

For warranty service or repair, this product must be returned to the factory. An RMA is required for products returned to Wavelength for warranty service. The Buyer shall prepay shipping charges to Wavelength and Wavelength shall pay shipping charges to return the product to the Buyer upon determination of defective materials or workmanship. However, the Buyer shall pay all shipping charges, duties, and taxes for products returned to Wavelength from another country.

LIMITATIONS OF WARRANTY

The warranty shall not apply to defects resulting from improper use or misuse of the product or operation outside published specifications. No other warranty is expressed or implied. Wavelength specifically disclaims the implied warranties of merchantability and fitness for a particular purpose.

EXCLUSIVE REMEDIES

The remedies provided herein are the Buyer’s sole and exclusive remedies. Wavelength shall not be liable for any direct, indirect, special, incidental, or consequential damages, whether based on contract, tort, or any other legal theory.

REVERSE ENGINEERING PROHIBITED

Buyer, End-User, or Third-Party Reseller are expressly prohibited from reverse engineering, decompiling, or disassembling this product.

NOTICE

The information contained in this document is subject to change without notice. Wavelength will not be liable for errors contained herein or for incidental or consequential damages in connection with the furnishing, performance, or use of this material. No part of this document may be translated to another language without the prior written consent of Wavelength.

SAFETY

There are no user-serviceable parts inside this product. Return the product to Wavelength Electronics for service and repair to ensure that safety features are maintained.

LIFE SUPPORT POLICY

This important safety information applies to all Wavelength electrical and electronic products and accessories:

As a general policy, Wavelength Electronics, Inc. does not recommend the use of any of its products in life support applications where the failure or malfunction of the Wavelength product can be reasonably expected to cause failure of the life support device or to significantly affect its safety or effectiveness. Wavelength will not knowingly sell its products for use in such applications unless it receives written assurances satisfactory to Wavelength that the risks of injury or damage have been minimized, the customer assumes all such risks, and there is no product liability for Wavelength. Examples of devices considered to be life support devices are neonatal oxygen analyzers, nerve stimulators (for any use), auto-transfusion devices, blood pumps, defibrillators, arrhythmia detectors and alarms, pacemakers, hemodialysis systems, peritoneal dialysis systems, ventilators of all types, and infusion pumps as well as other devices designated as “critical” by the FDA. The above are representative examples only and are not intended to be conclusive or exclusive of any other life support device.

REVISION HISTORY

DOCUMENT NUMBER: HTCSERIES-00400

REV.	DATE	CHANGE
0	Oct. 2019	Transferred to new format and combined all HTC models



**WAVELENGTH
ELECTRONICS**

51 Evergreen Drive
Bozeman, Montana 59715

406-587-4910 (tel)

406-587-4911 (fax)

Sales & Tech Support

sales@teamwavelength.com

techsupport@teamwavelength.com