

## SPECIFICATION OF THERMOELECTRIC MODULE AMS-125-1.4-2.5CH (40x40) HT120 E L2 72K



Thermoelectric parameters	Unit	Value
<b>I<sub>max</sub></b>	<b>Amps</b>	<b>3,7</b>
<b>U<sub>max</sub></b>	<b>Volts</b>	<b>16,0</b>
<b>ΔT<sub>max</sub></b>	<b>K</b>	<b>72</b>
<b>Q<sub>max</sub></b>	<b>Watts</b>	<b>36,8</b>
<b>R<sub>ac</sub> (at 295 K), ±10%</b>	<b>Ohm</b>	<b>3,1</b>
<i>All parameters except R<sub>ac</sub> are given at Th=300 K</i>		

Option	Unit	Value
<b>Ceramic material</b>	-	<b>Al<sub>2</sub>O<sub>3</sub></b>
<b>Height tolerance</b>	<b>mm</b>	<b>± 0,025</b>
<b>Flatness</b>	<b>mm</b>	<b>0,015</b>
<b>Parallelism</b>	<b>mm</b>	<b>0,02</b>
<b>Sealant: epoxy</b>	-	<b>E</b>
<b>Max. processing temperature*</b>	<b>°C</b>	<b>130</b>
<b>Max. operating temperature</b>	<b>°C</b>	<b>120</b>
<b>Type of lead wires</b>	-	<b>22 AWG</b>
<b>ROHS compliance</b>	-	<b>Yes</b>

\* The maximum processing temperature influence on the module and must not exceed 2 minutes

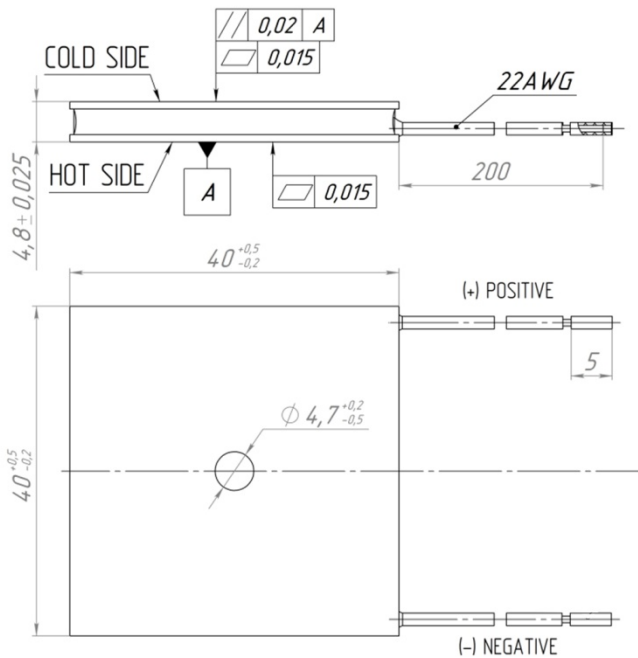

TEM no solder tabs, 200mm wires, the TEM wires stripped and without tinning, the cut insulation remaining at the wire end.

Manufactured by:



6 Aerodromnaya street, Saint-Petersburg, 197348 Russia

