

The **FCI-GaAs-XXM** is a 4 or 12 element GaAs PIN photodetector array designed for high speed fiber receiver and monitoring applications. The 70 $\mu$ m diameter elements are capable of 2.5Gbps data rates. AR coated and sensitive to telecommunication wavelengths, this array is a perfect receiver for SM or MM fiber ribbon with a 250 $\mu$ m pitch. The FCI-GaAs-XXM comes standard on a wraparound ceramic submount. Board level contacts have a 0.5mm pitch.

If you need a custom array or require special testing for your OSI Optoelectronics part, please contact our Applications department.

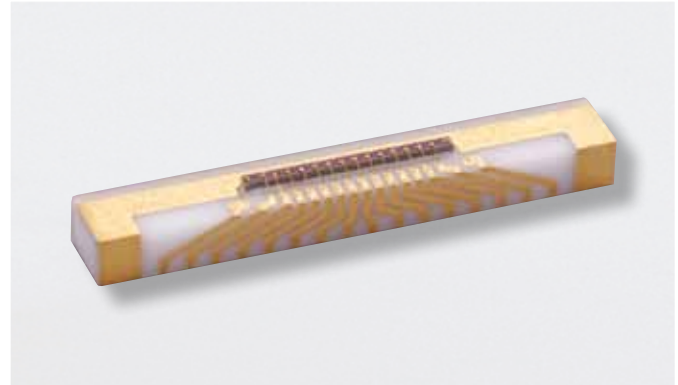

### FCI-GaAs-12M

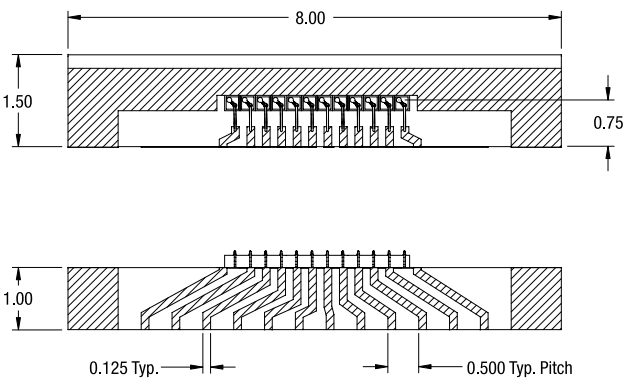

### FCI-GaAs-4M

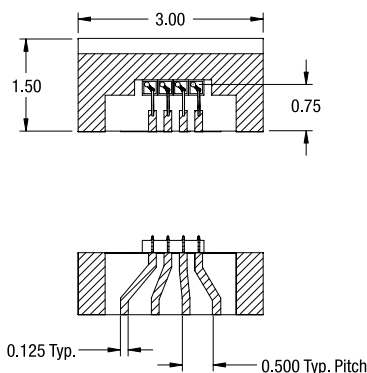

#### Notes:

- All units in millimeters.
- All devices are mounted with low out gassing conductive epoxy with tolerance of  $\pm 25\mu$ m.

#### APPLICATIONS

- Fiber Optic Receiver
- DWDM Monitor
- SM or MM Fiber Ribbon
- Parallel Interconnects

#### FEATURES

- High Speed
- High Responsivity
- AR Coated Elements
- Wraparound Ceramic Submount
- Spectral Range 650nm to 860nm



info@amstechnologies.com  
www.amstechnologies-webshop.com



Electro-Optical Characteristics		$T_A = 23^\circ\text{C}$ , $V_R = 5\text{V}$
PARAMETERS	FCI-GaAs-4M	FCI-GaAs-12M
Active Area Diameter	70 $\mu$ m, Pitch:250 $\mu$ m	
Responsivity	Typ. 0.63A/W @850nm	
Capacitance	Typ. 0.65pF	
Dark Current	Typ. 0.03nA	
Max. Reverse Voltage	20V	
Max. Forward Current	5mA	
Bandwidth	Typ. 2.0GHz @ 850nm	
Breakdown Voltage	Typ. 50V	
Storage Temperature Range	From -40 to 85 $^\circ\text{C}$	
Operating Temperature Range	From 0 to 70 $^\circ\text{C}$	