

THIS DOCUMENT IS THE PROPERTY OF LYTRON, INC. AND REPRESENTS A PROPRIETARY ARTICLE ON WHICH LYTRON, INC. RETAINS ANY AND ALL PATENT AND OTHER RIGHTS, INCLUDING EXCLUSIVE RIGHTS OF USE AND/OR MANUFACTURE AND/OR SALE. POSSESSION OF THIS DOCUMENT DOES NOT CONVEY ANY PERMISSION TO REPRODUCE THE DOCUMENT OR MANUFACTURE THE ARTICLE OR ARTICLES SHOWN THEREIN.

REVISIONS						
ZONE	REV.	DESCRIPTION	DATE	DES	CHK	APP'D
	A	INITIAL RELEASE	3/10/00	JFP		APT
	B	REV'D & REDRAWN ADDED NOTES AND INSPECTION MARKS AND DATUMS	10/26/01	CDM		PRV
	C	REV PER ECN 10191	9/21/01	DMG		CDM
	D	REV PER ECN 14842	2/19/08	JBP		PRV
	E	ADD FLATNESS SPEC PER ECN 16166	2-13-09	WS	JMP	JMP

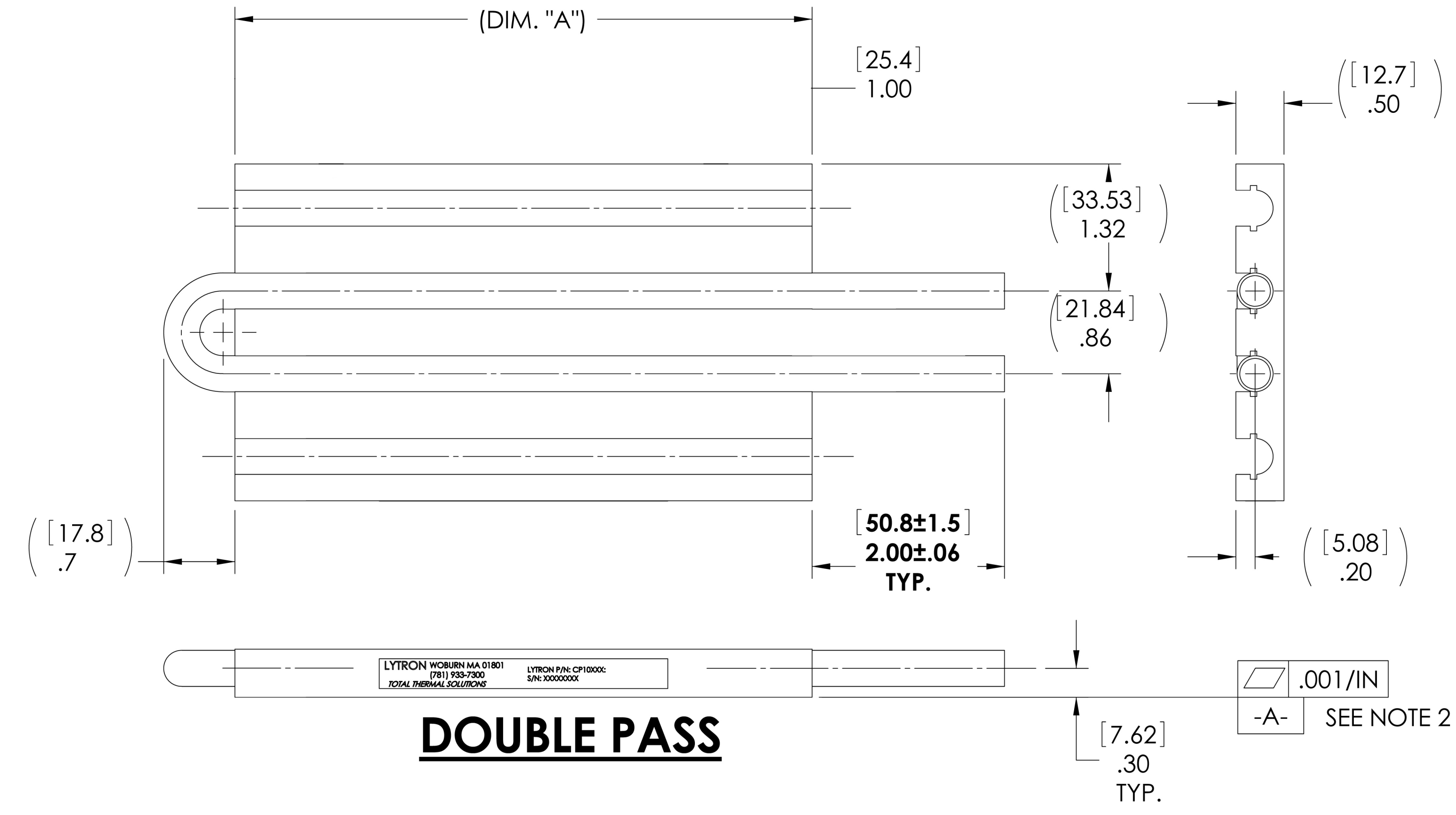

DOUBLE PASS

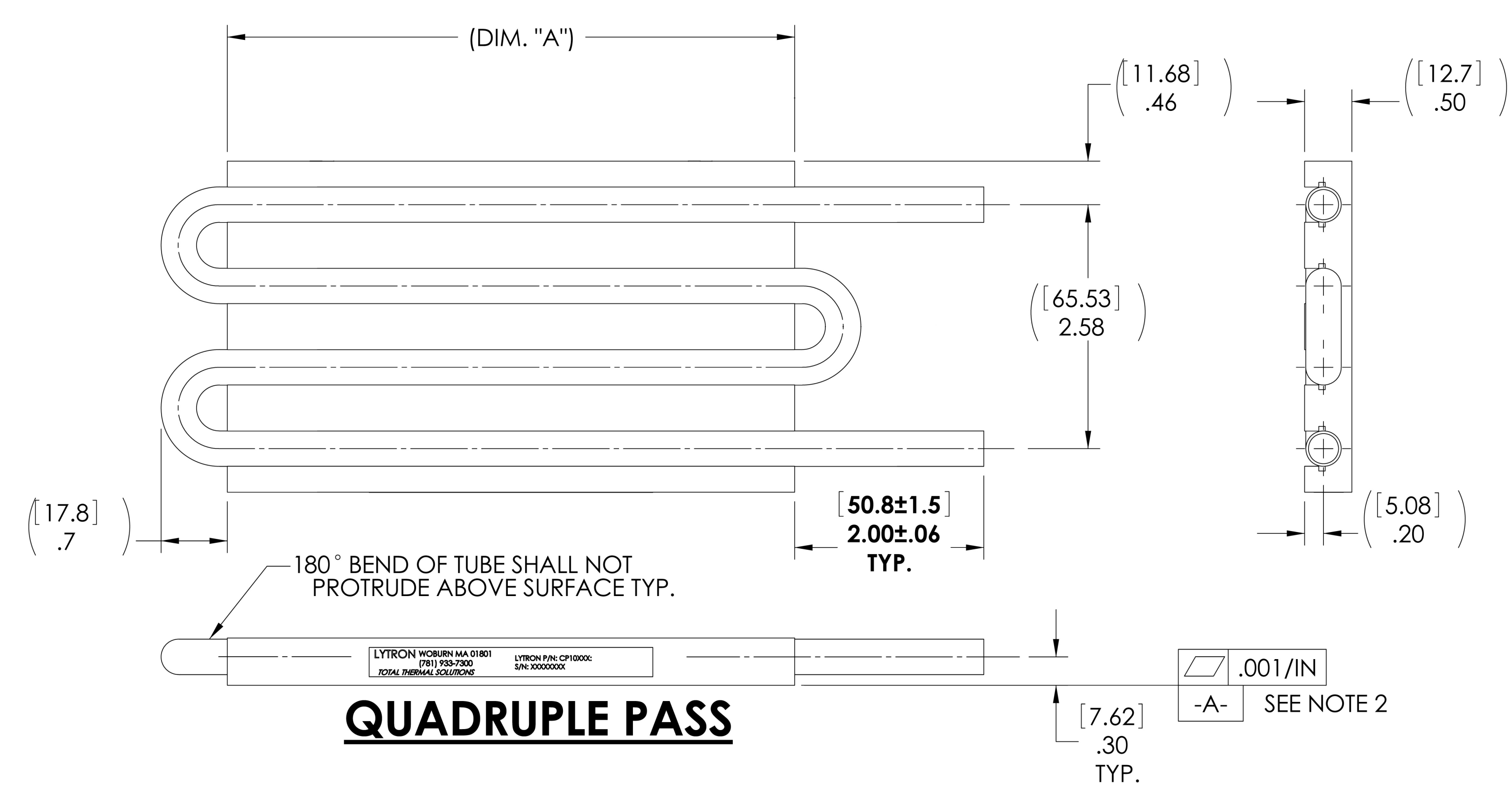

QUADRUPLE PASS

LYTRON P/N	(DIM. "A")	TUBING MAT'L	I/O FITTING STYLE	CONFIGURATION
CP10G01	6.00 [152.4]	COPPER	STRAIGHT	DOUBLE PASS
CP10G03	6.00 [152.4]	STAINLESS STEEL	STRAIGHT	DOUBLE PASS
CP10G05	12.00 [304.8]	COPPER	STRAIGHT	DOUBLE PASS
CP10G07	12.00 [304.8]	STAINLESS STEEL	STRAIGHT	DOUBLE PASS
CP10G14	6.00 [152.4]	COPPER	STRAIGHT	QUADRUPLE PASS
CP10G16	6.00 [152.4]	STAINLESS STEEL	STRAIGHT	QUADRUPLE PASS
CP10G18	12.00 [304.8]	COPPER	STRAIGHT	QUADRUPLE PASS
CP10G20	12.00 [304.8]	STAINLESS STEEL	STRAIGHT	QUADRUPLE PASS

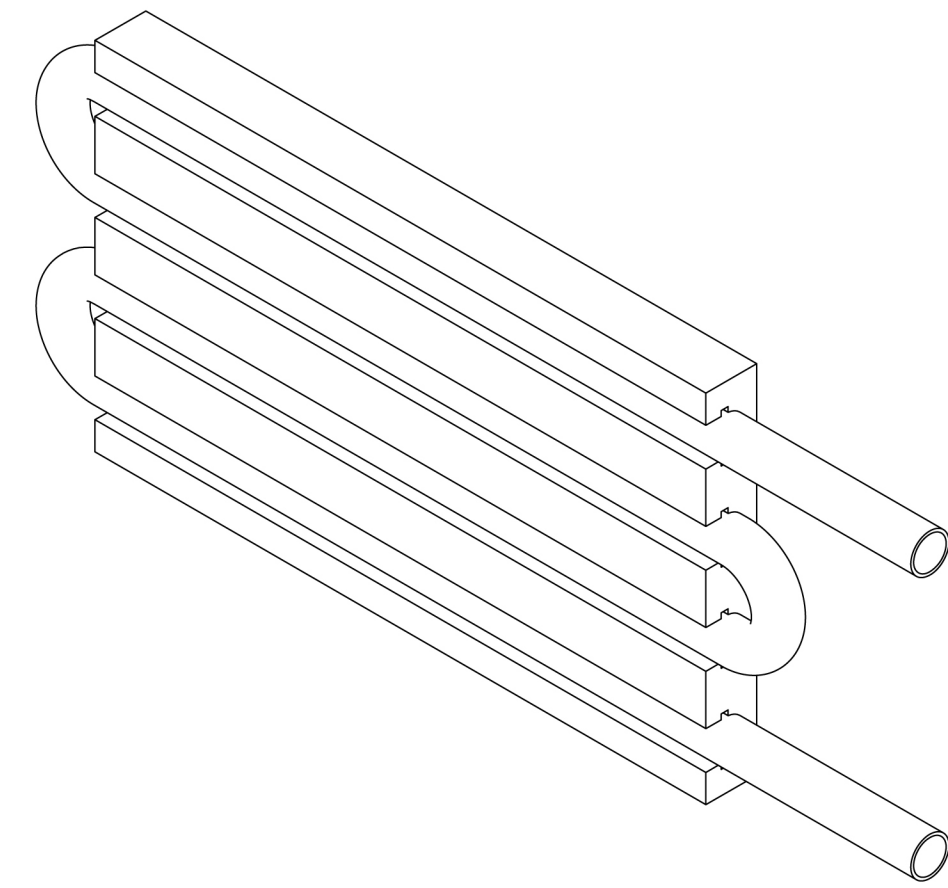
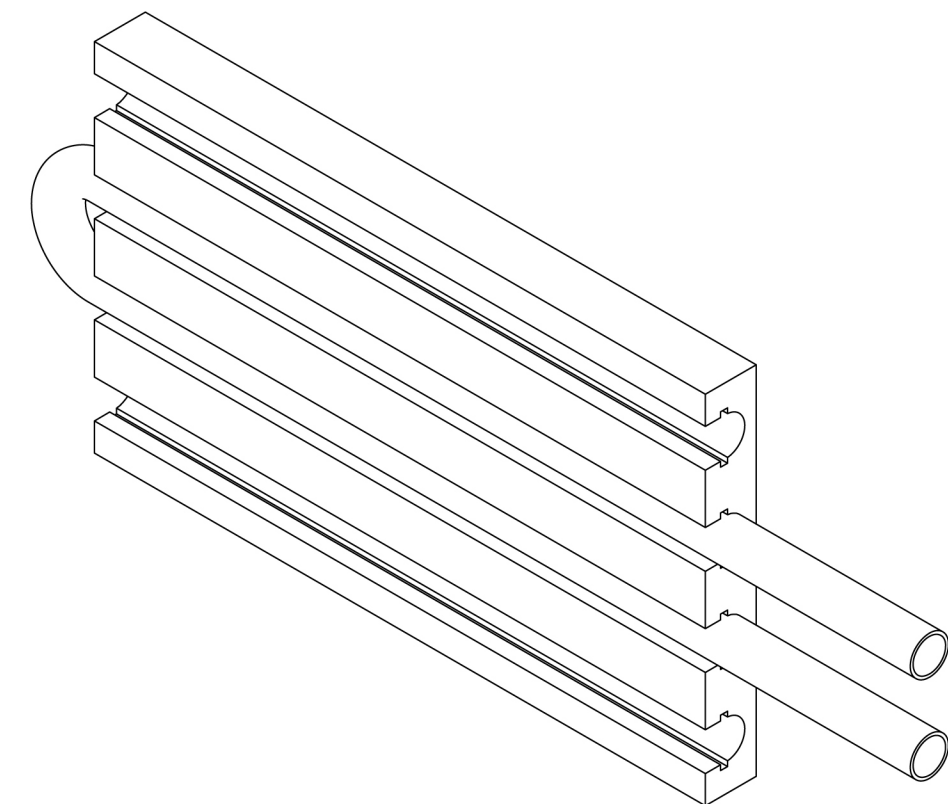

3/8" O.D. STRAIGHT TUBE

- NOTES:
- MATERIAL:
PLATE: ALUMINUM
TUBING CIRCUIT: STAINLESS STEEL OR COPPER.
 - FLATNESS .001"/IN [.025 MM / 25.4 MM]
 - DIMENSIONS IN [] ARE IN MILLIMETERS.

QTY REQD	PART OR IDENT NO.	DESCRIPTION	ITEM NO
LIST OF MATERIALS OR PARTS LIST			
UNLESS OTHERWISE SPECIFIED		REDRAWN C/MARSHALL	DATE 10/26/01
ANGULAR DIMENSIONS ± 5° SURFACE ROUGHNESS (3.2 μ) BREAK EDGES .010 (25mm) MAX. REMOVE ALL BURRS		DRAWN J PLOURDE	DATE 3/9/00
TOLERANCE ON DECIMALS		APPROVED A THOMAS	DATE 3/10/00
INCH .X .XX .XXX ±.1 ±.03 ±.005		APPROVED	
MILLIMETER ±XX ±XX ±XXX		DO NOT SCALE THIS DRAWING	
THIRD ANGLE PROJECTION		MATERIAL SEE TABLE	SIZE D
DIMENSIONS AND TOLERANCING ARE PER ANSI STD Y14.5		FINISH NONE	FSCM NO. 11245
NEXT ASSY	USED ON	DRAWING NO. S-CP10GXX	REV E
APPLICATION		SCALE 1/1	WT. SHEET 1 OF 1

LYTRON INCORPORATED
WOBURN, MASSACHUSETTS
DRAWING TITLE
**COLD PLATE
(PRESS-LOCK)**