

DATASHEET AND OPERATING GUIDE

MULTI-HTSK

Multi-Product Heatsink



FEATURES & BENEFITS

- Supports multiple product packages
- Excellent thermal conductivity
- Includes mounting hardware and one package of thermal paste

GENERAL DESCRIPTION:

The Heatsink is designed to support a range of Wavelength products during product evaluation.

A chart is provided on page 2 to calculate acceptable operating range for each Wavelength product model supported.

USED WITH

- LDTCxx20 Series Laser Diode & Temperature Controllers
- LDTC2/2 E Laser Diode & Temperature Controller
- MPL250, MPL500 & MPL2500 Laser Diode Drivers
- MPT2500 & MPT5000 Temperature Controllers
- PLD5K-CH Laser Diode Driver
- PTC2.5K-CH & PTC5K-CH Temperature Controllers

CONTENTS

	PAGE
SAFE OPERATING AREA	2
ASSEMBLY INSTRUCTIONS	2
THERMAL PERFORMANCE	3
MECHANICAL SPECIFICATIONS	4
CERTIFICATION AND WARRANTY	5

ORDERING INFORMATION

PART NO	DESCRIPTION
MULTI-HTSK	Multi-Product Heatsink



SAFE OPERATING AREA



TO DETERMINE IF THE MULTI-HTSK HEATSINK IS REQUIRED IN YOUR APPLICATION, IT IS IMPERATIVE THAT YOU VERIFY THE UNIT WILL BE OPERATING WITHIN THE INTERNAL HEAT DISSIPATION SAFE OPERATING AREA (SOA).

Visit the Wavelength Electronics website for the most accurate, up-to-date, and easy to use SOA calculator.

The SOA calculator for Laser Diode Drivers is at this page:
<http://www.teamwavelength.com/support/calculator/soa/soald.php>

The SOA calculator for Temperature Controllers:
<http://www.teamwavelength.com/support/calculator/soa/soatc.php>



Figure 1. Thermal Paste

ASSEMBLY INSTRUCTIONS

A single heatsink model is provided for a broad range of products. Wavelength products can be mounted on the heatsink as shown in **Figures 2-5**.

Thermal paste should be applied evenly across the mounting area, prior to mounting.

1. Clean and dry all surfaces where the product will contact the heatsink.
2. Spread the thermal paste on the surface of the product that will contact the heatsink. Thermal paste is available from Wavelength Electronics, P/N THERM-PST. One package is provided with purchase of the heatsink.
3. Secure the product to the heatsink with screws as shown by the red circles in **Figures 2-5**.

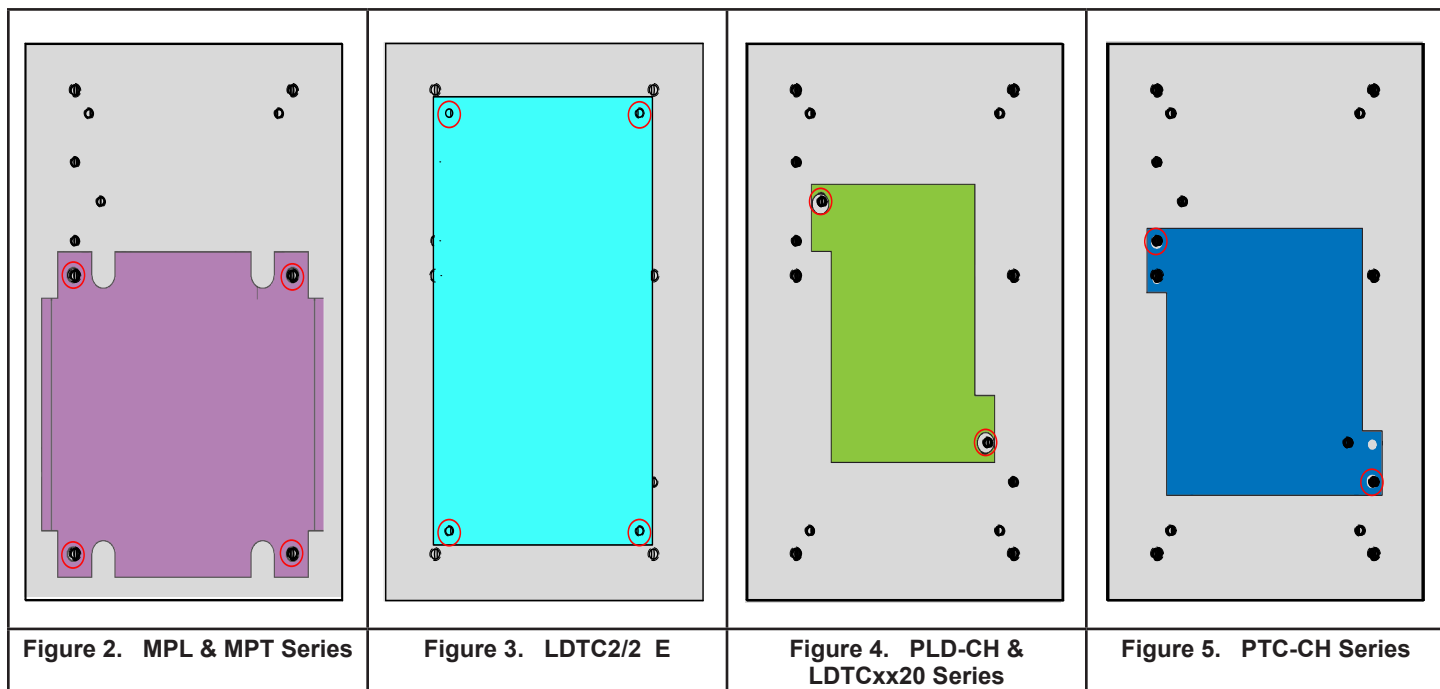

THERMAL PERFORMANCE

NATURAL CONVECTION

With “natural convection” (no fan), the maximum internal dissipated power of a device on this heat sink is limited to 18 W. The still air configuration can lead to thermal runaway above the 18 W range.

FORCED CONVECTION

With forced air, the maximum dissipated power of a device on this heat sink is as much as 40 W, depending on air flow. The range depends on the distribution of power between the drive transistor(s) and the sense resistor(s), the supply voltage, and the load characteristics.

INTERNAL POWER DISSIPATION CALCULATION

Table 1 provides a means to calculate the worst case internal power dissipation for your application and ensure proper operation within the Safe Operating Area (SOA).

- A. Enter your supply voltage (V), laser diode or thermoelectric voltage (V), and operating current (A) in the columns provided (1, 2 and 3).
- B. Calculate the internal power dissipation by subtracting column 2 from column 1 ($V_{\text{SUPPLY}} - V_{\text{LOAD}}$), then multiplying the voltage (V) by the current (A) entered in column 3. This equals the maximum internal power dissipation in Watts.
- C. Enter the calculated value into column 4.
- D. Compare the calculated value with the limits shown in columns 5 through 7 to confirm operation with and without air flow.

The forced air specifications are based on 10 CFM air flow through the fan with an ambient temperature of 25 °C. Maximum heat sink temperature is 50 °C. Thermal paste is used on all contacting surfaces.

Table 1. Internal Power Dissipation Calculation Chart

MODEL NUMBER	1 SUPPLY VOLTAGE	2 TE or DIODE VOLTAGE DROP (worst case)	3 * OPERATING CURRENT (application specific value)	4 CALCULATED INTERNAL POWER DISSIPATION	5 MODULE ABSOLUTE MAX POWER DISSIPATION (per datasheet)	6 MAXIMUM POWER DISSIPATION (MULTI-HTSK & 10 CFM FAN)	7 MAXIMUM POWER DISSIPATION (NATURAL CONVECTION)
LDTC0520					11 W	11 W	11 W
LDTC1020					13 W	13 W	13 W
LDTC2/2 E					18 W	18 W	18 W
MPL250					4 W	4 W	4 W
MPL500					8 W	8 W	6 W
MPL2500					40 W	40 W	6 W
MPT2500					15 W	15 W	9 W
MPT5000					30 W	30 W	9 W
PLD5K-CH					15 W	15 W	9 W
PTC2.5K-CH					60 W	30 W	10 W
PTC5K-CH					60 W	30 W	10 W

A utility to calculate the Safe Operating Area (SOA) for your unit can be found online at:
<http://www.teamWavelength.com/support/calculator/soa/soald.php> (laser diode drivers) or
<http://www.teamWavelength.com/support/calculator/soa/soatc.php> (temperature controllers).

MECHANICAL SPECIFICATIONS

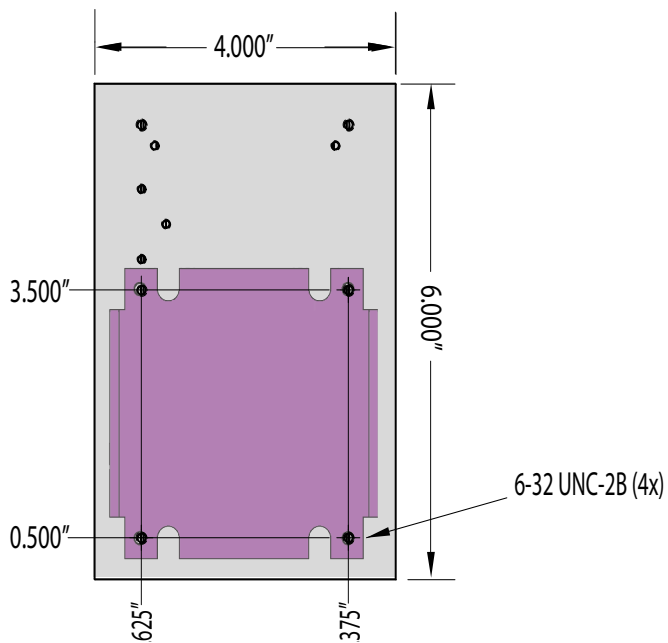

Figure 6. MPL & MPT Series

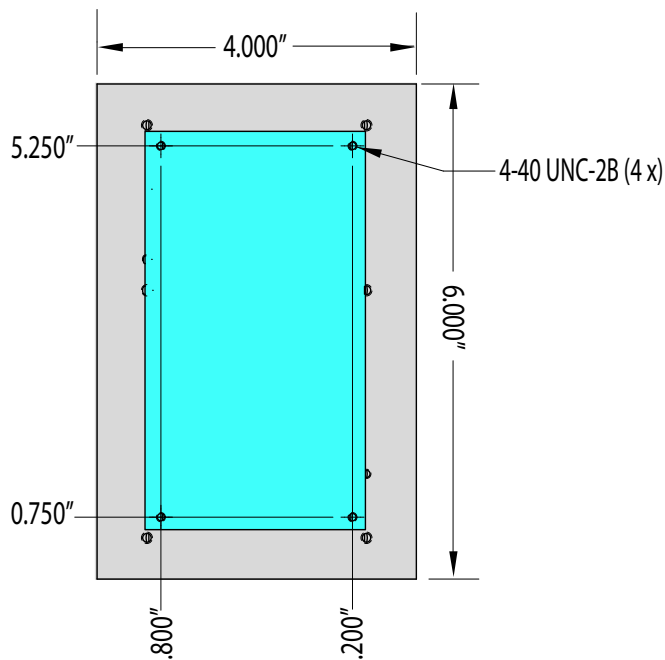

Figure 7. LDTC2/2 E

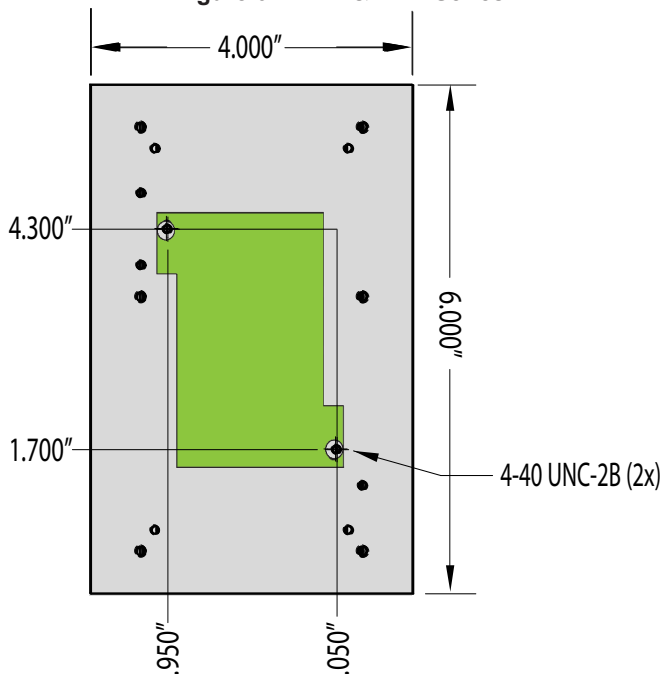

Figure 8. PLD5K-CH

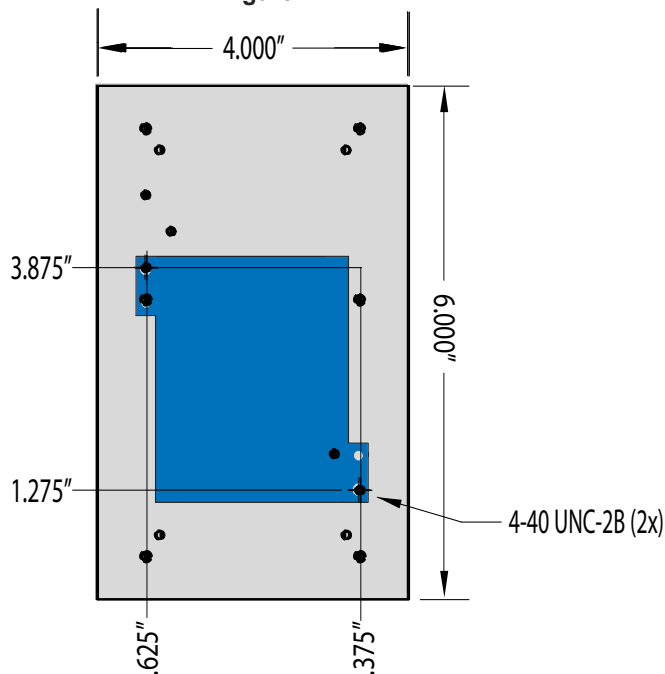

Figure 9. PTC2.5K-CH & PTC5K-CH

Figure 10 shows the fin spacing on the heat sink when viewed from the end.

Thermal resistance ($^{\circ}\text{C} / \text{W}$ at 6" length): 1.57.

All dimension tolerances are ± 0.01 inches.

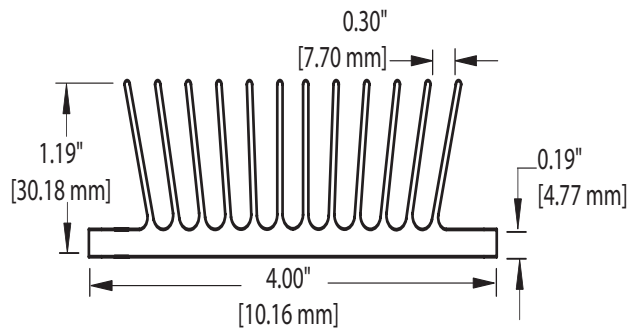

Figure 10. MULTI-HTSK Dimensions

CERTIFICATION AND WARRANTY

CERTIFICATION

Wavelength Electronics, Inc. (Wavelength) certifies that this product met its published specifications at the time of shipment. Wavelength further certifies that its calibration measurements are traceable to the United States National Institute of Standards and Technology, to the extent allowed by that organization's calibration facilities, and to the calibration facilities of other International Standards Organization members.

WARRANTY

This Wavelength product is warranted against defects in materials and workmanship for a period of one (1) year from date of shipment. During the warranty period, Wavelength will, at its option, either repair or replace products which prove to be defective.

WARRANTY SERVICE

For warranty service or repair, this product must be returned to the factory. An RMA is required for products returned to Wavelength for warranty service. The Buyer shall prepay shipping charges to Wavelength and Wavelength shall pay shipping charges to return the product to the Buyer upon determination of defective materials or workmanship. However, the Buyer shall pay all shipping charges, duties, and taxes for products returned to Wavelength from another country.

LIMITATIONS OF WARRANTY

The warranty shall not apply to defects resulting from improper use or misuse of the product or operation outside published specifications. No other warranty is expressed or implied. Wavelength specifically disclaims the implied warranties of merchantability and fitness for a particular purpose.

EXCLUSIVE REMEDIES

The remedies provided herein are the Buyer's sole and exclusive remedies. Wavelength shall not be liable for any direct, indirect, special, incidental, or consequential damages, whether based on contract, tort, or any other legal theory.

REVERSE ENGINEERING PROHIBITED

Buyer, End-User, or Third-Party Reseller are expressly prohibited from reverse engineering, decompiling, or disassembling this product.

NOTICE

The information contained in this document is subject to change without notice. Wavelength will not be liable for errors contained herein or for incidental or consequential damages in connection with the furnishing, performance, or use of this material. No part of this document may be translated to another language without the prior written consent of Wavelength.

SAFETY

There are no other user-serviceable parts inside this product. Return the product to Wavelength for service and repair to ensure that safety features are maintained.

LIFE SUPPORT POLICY

This important safety information applies to all Wavelength electrical and electronic products and accessories:

As a general policy, Wavelength Electronics, Inc. does not recommend the use of any of its products in life support applications where the failure or malfunction of the Wavelength product can be reasonably expected to cause failure of the life support device or to significantly affect its safety or effectiveness. Wavelength will not knowingly sell its products for use in such applications unless it receives written assurances satisfactory to Wavelength that the risks of injury or damage have been minimized, the customer assumes all such risks, and there is no product liability for Wavelength. Examples of devices considered to be life support devices are neonatal oxygen analyzers, nerve stimulators (for any use), auto-transfusion devices, blood pumps, defibrillators, arrhythmia detectors and alarms, pacemakers, hemodialysis systems, peritoneal dialysis systems, ventilators of all types, and infusion pumps as well as other devices designated as "critical" by the FDA. The above are representative examples only and are not intended to be conclusive or exclusive of any other life support device.

REVISION HISTORY

DOCUMENT NUMBER: MULTI-HTSK400

REV.	DATE	CHANGE
G	October 2013	Release in new format and extend warranty

