

FIBER OPTIC 1xN / 2xN SWITCH *coaxial design*

OVERVIEW

Sercalo's fiber optic 1xN and 2xN switches are bidirectional opto-mechanical switches based on a coaxial design where a single MEMS mirror redirects light from a common fiber to one of N ports. The MEMS technology results in low insertion loss and low crosstalk between channels while keeping a constant switching performance over life.

The switch is available in several different variants to simplify integration in existing systems and reduce development cost. The miniature packages withstands rugged environments and is well suited for direct mounting on printed circuit boards.

The hermetically sealed MEMS and the laser welded fiber collimator guarantee broad temperature range and superior long term stability. No epoxy is present in the optical path.

The component is compliant to Telcordia 1221 reliability standards and RoHS requirements 2015/863/EU.

FEATURES

- Low insertion loss
- Reliable
- Up to 2x256 optical ports
- UART, I²C/SMBus and parallel interface
- Ethernet interface available on request
- RoHS compliant

APPLICATIONS

- Optical network switching
- Instrumentation
- Test and measurement

Contact:

Sercalo Microtechnology Ltd.

Landstrasse 151

9494 Schaan - Principality of Liechtenstein

Tel. +423 237 57 97 Fax. +423 237 57 48

<http://www.sercalo.com> e-mail: info@sercalo.com

ORDERING INFORMATION

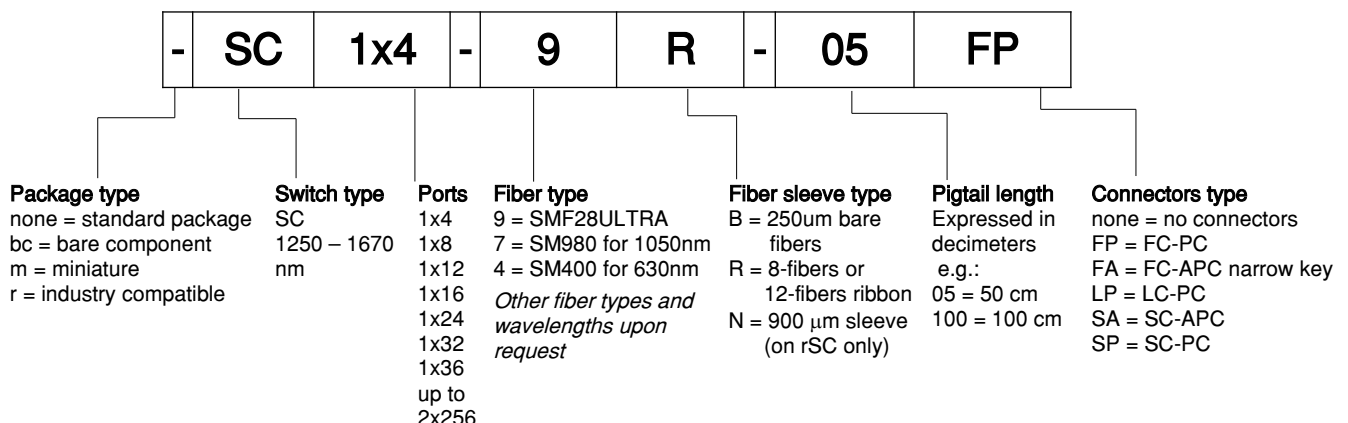

Sercalo's COAXIAL TYPE 1xN switch is non latching: at power-off it breaks the optical connection and routing of the common port is not defined. The component is bidirectional, i.e. the common port can be used as input or output of the light signal.

The switch is available in four different variants:

SC: standard size – ribbon fibers

mSC: miniature size – small driver board: 7x40 mm

rSC: compatible with industry pinout, 900 µm sleeved fibers and connectors

bcSC: bare optical component

TECHNICAL SPECIFICATIONS *for Single Mode fiber*

	<i>Unit</i>	<i>Min</i>	<i>Typ</i>	<i>Max</i>
Optical Specifications				
Wavelength range ¹	nm	1250		1670
Insertion loss 1x4 ²	dB		0.4	1.0
Insertion loss 1x8 to 1x16 ²	dB		0.8	1.2
Insertion loss 1x24 ²	dB		1.0	1.5
Insertion loss 1x32 to 1x36 ²	dB		1.2	2.0
Crosstalk	dB	50	60	
Polarisation dependent loss	dB			0.1
Return loss	dB	50	55	
Wavelength dep. loss (one band)	dB			0.2
Wavelength dep. loss (1250-1650 nm)	dB		0.5	1.0
Temperature dependent loss	dB			0.2
Maximum optical power level ³	mW			500
Switching time	ms		5	10
Cycle rate	Hz		10	50
Repeatability ⁴	dB			0.01
Durability	cycles		No wear out	
Electrical Specifications (SC, mSC, rSC)				
Supply voltage	V	4.75	5	5.25
Power consumption, normal mode	mW			150
Power consumption, standby	mW		40	
UART speed	baud	9600		115200
SMBus/I ² C bus speed	kbps			400
Input logic level low	V		0	0.6
Input logic level high	V	2.4	5	
Output logic level low	V		0	0.6
Output logic level high	V	2.6	3.3	
Reset inactive voltage ⁵	V	2.4	5	
Reset active voltage	V		0	0.9
Reset pulse duration	µs	15		
Electrical Specifications (bcSC)				
Driving voltage	V	0		42
Driving voltage damage threshold	V			45
Electrostatic discharge tolerance ⁶	V			50
Package				
Operating temperature	°C	-10		70
Storage temperature	°C	-40		85
Operation humidity (non condensing)	% r.h.	0		95
Pigtail length	cm	50		100
Dimensions	SC	mm	40 x 21 x 7	
	mSC	mm	40 x 7 x 7.5	
	rSC	mm	68 x 30 x 9	
	bcSC	mm	Ø6 x 35	
ROHS Compliance			2015/863/EU (no exceptions)	

¹ Insertion loss over all bands. By optimizing a single band the max IL value is 0.3 dB lower. ² Values at 25 °C at 1550 nm, without connectors. For operation over several bands 1250 to 1670 add 0.5 dB. ³ It is recommended to turn off the laser during switch transients when switching optical power above 100 mW. ⁴ For constant temperature and polarization. ⁵ Through onboard pull-up resistor. ⁶ The bare optical component is not protected against ESD.

FUNCTIONAL BLOC DIAGRAM

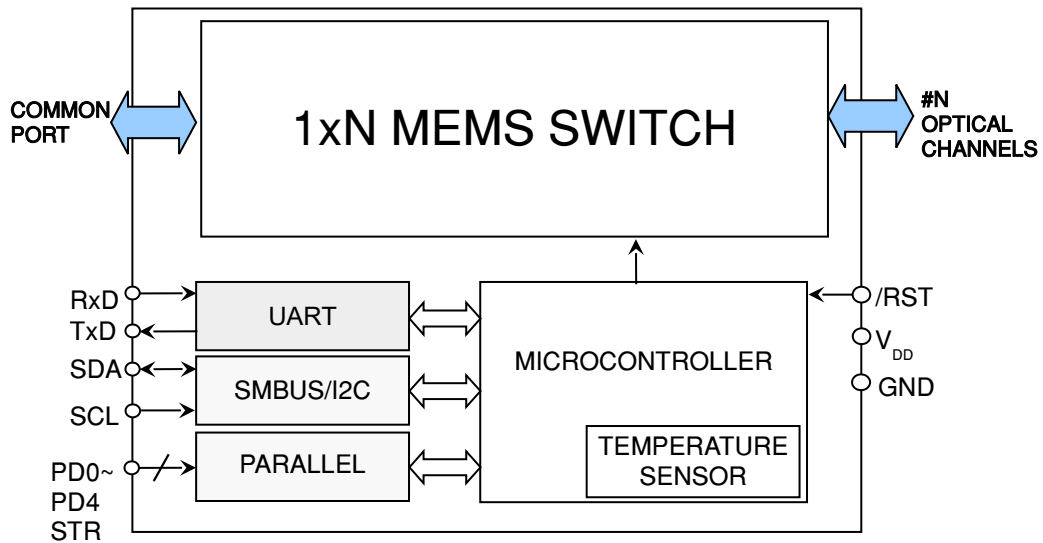

SC STANDARD SIZE – DIMENSIONS AND PINOUT

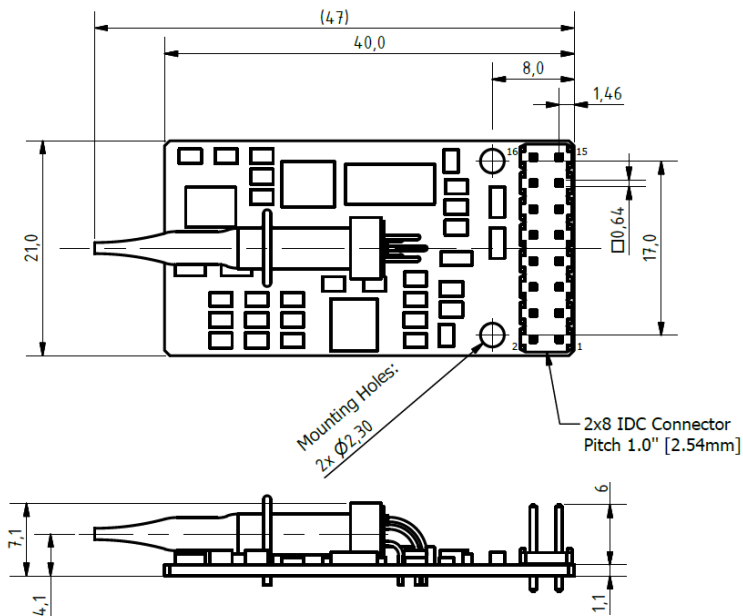

Pin number	Description
1	Parallel PD3
2	Parallel PD4
3	Parallel PD1
4	Parallel PD2
5	Parallel STROBE/ENABLE
6	Parallel PD0
7	Ground (GND)
8	Supply voltage (V _{DD})
9	Reserved
10	UART TX
11	Reserved
12	UART RX
13	System reset (RST)
14	SMBus/I ² C SDA
15	SMBus/I ² C SCL
16	Ground (GND)

mSC MINIATURE – DIMENSIONS AND PINOUT

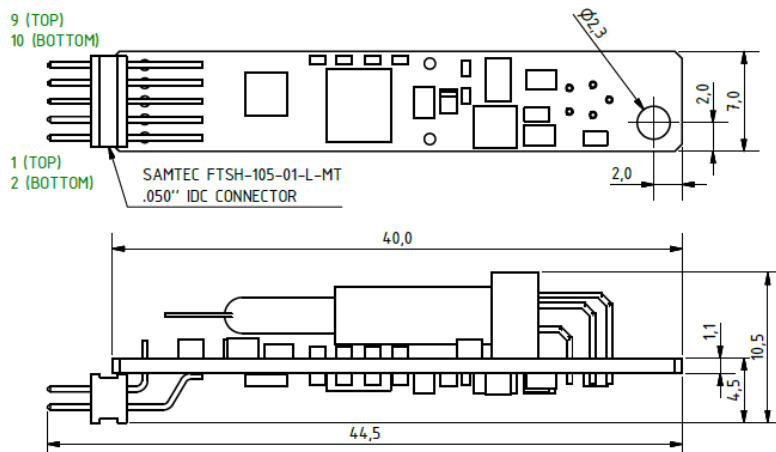

Pin number	Description
1	I/F mode
2	Supply voltage (V _{DD})
3	System reset (RST)
4	Ground (GND)
5	SMBus/I ² C A0
6	SMBus/I ² C A2 / UART RX
7	SMBus/I ² C A1 / UART TX
8	SMBus/I ² C SCL
9	SMBus/I ² C A3
10	SMBus/I ² C SDA

rSC 1x4/1x8/1x16 INDUSTRY COMPATIBLE – DIMENSIONS AND PINOUT

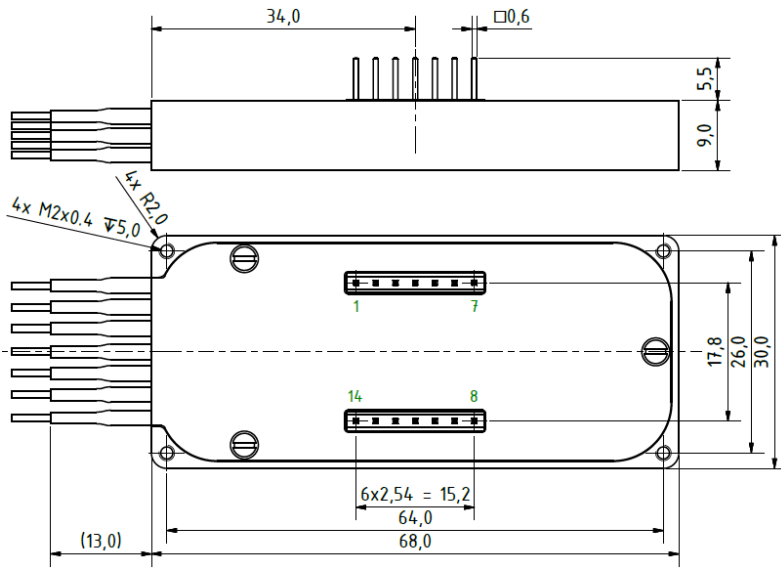

number	Description
1	Not connected
2	Supply voltage (V _{DD})
3	Parallel strobe
4	Signal ground
5	Parallel D0 / SMBus/I ² C A0
6	SMBus/I ² C SDA
7	SMBus/I ² C SCL
8	I/F mode
9	Parallel D2 / SMBus/I ² C A2
10	Done
11	Case ground
12	Parallel D1 / SMBus/I ² C A1
13	Parallel D3 / SMBus/I ² C A3
14	System reset (RST)

rSC 1x24/1x32 UP TO 2x256 INDUSTRY COMPATIBLE – DIMENSIONS AND PINOUT

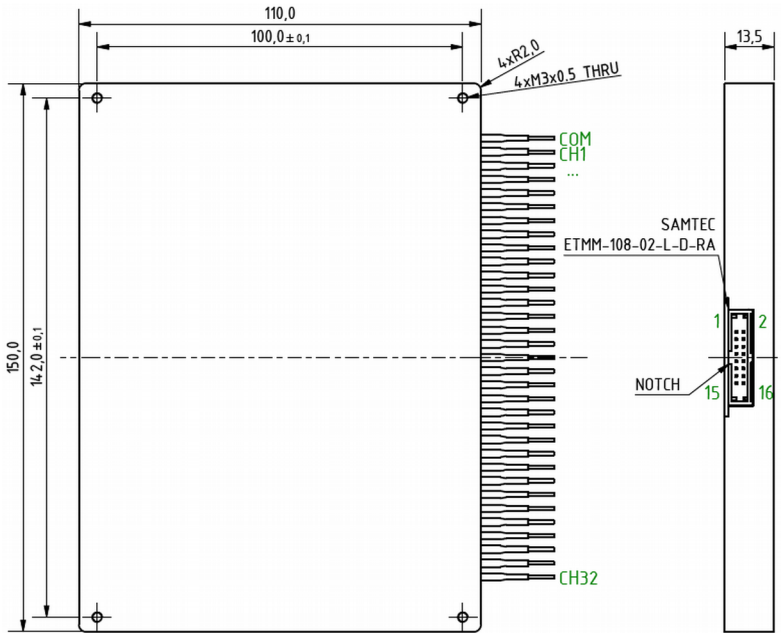

Pin number	Description
1	System reset (RST)
2	SMBus/I ² C SCL
3	SMBus/I ² C SDA
4	Reserved
5	Reserved
6	Reserved
7	UART RX
8	UART TX
9	Reserved
10	Reserved
11	Ground (GND)
12	Ground (GND)
13	Supply voltage (V _{DD})
14	Supply voltage (V _{DD})
15	Reserved
16	Reserved

bcSC BARE OPTICAL COMPONENT – DIMENSIONS AND PINOUT

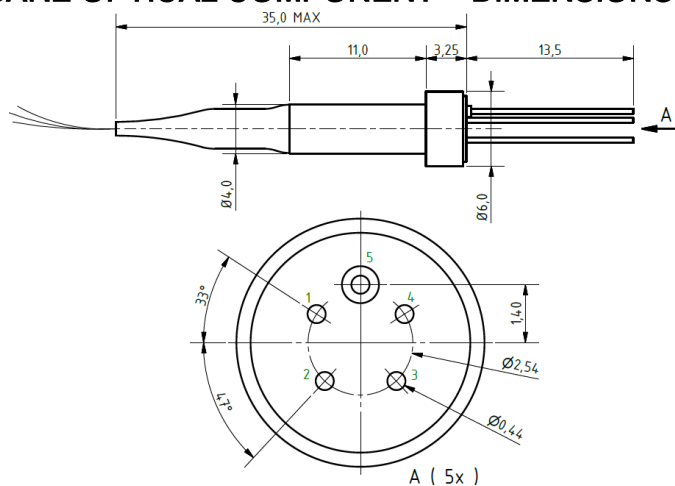

Pin number	Description
1	Axis X-
2	Axis Y-
3	Axis X+
4	Axis Y+
5	Common

INSERTION LOSS vs. TEMPERATURE (SC 1x8)

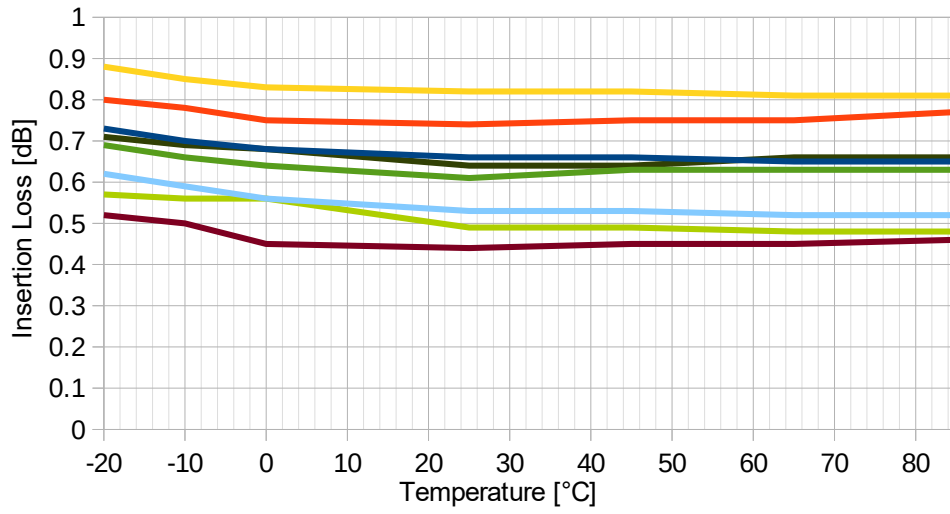

WAVELENGTH DEPENDENT LOSS (SC 1x4)

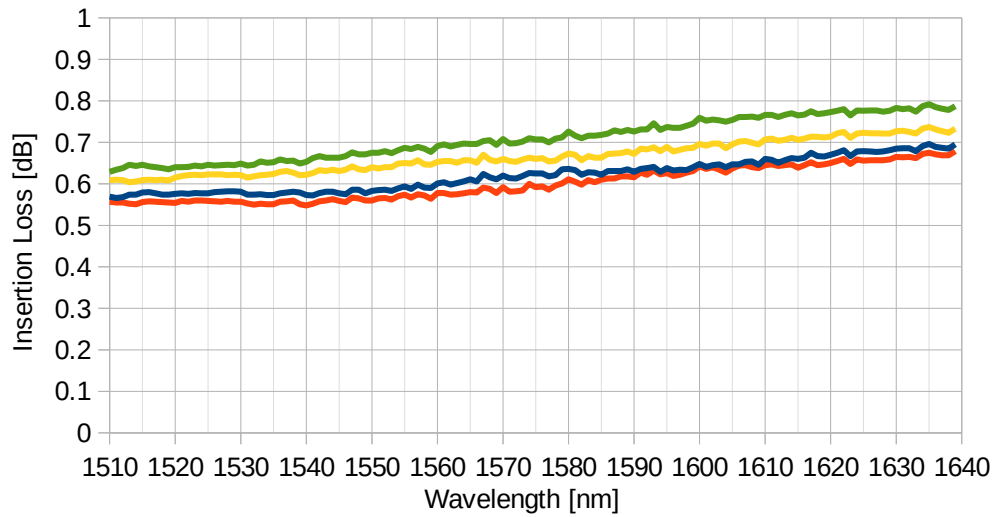

OPTICAL RESPONSE TIME

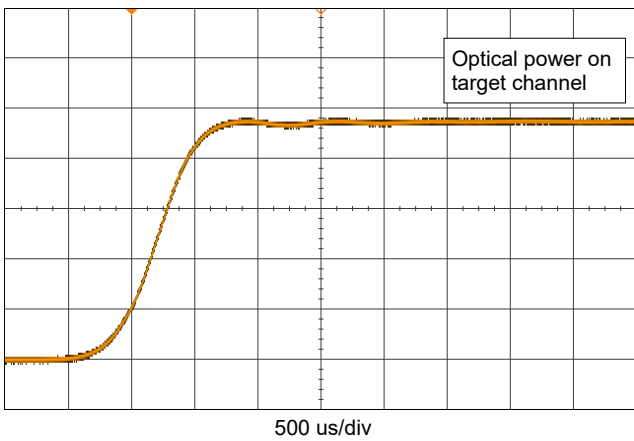

CONTINUOUS SWITCH OPERATION

