

SPECIFICATIONS



Model Number: GL48B7
Part Number: 19031377A

June 20, 2015

Mechanical Drawing:

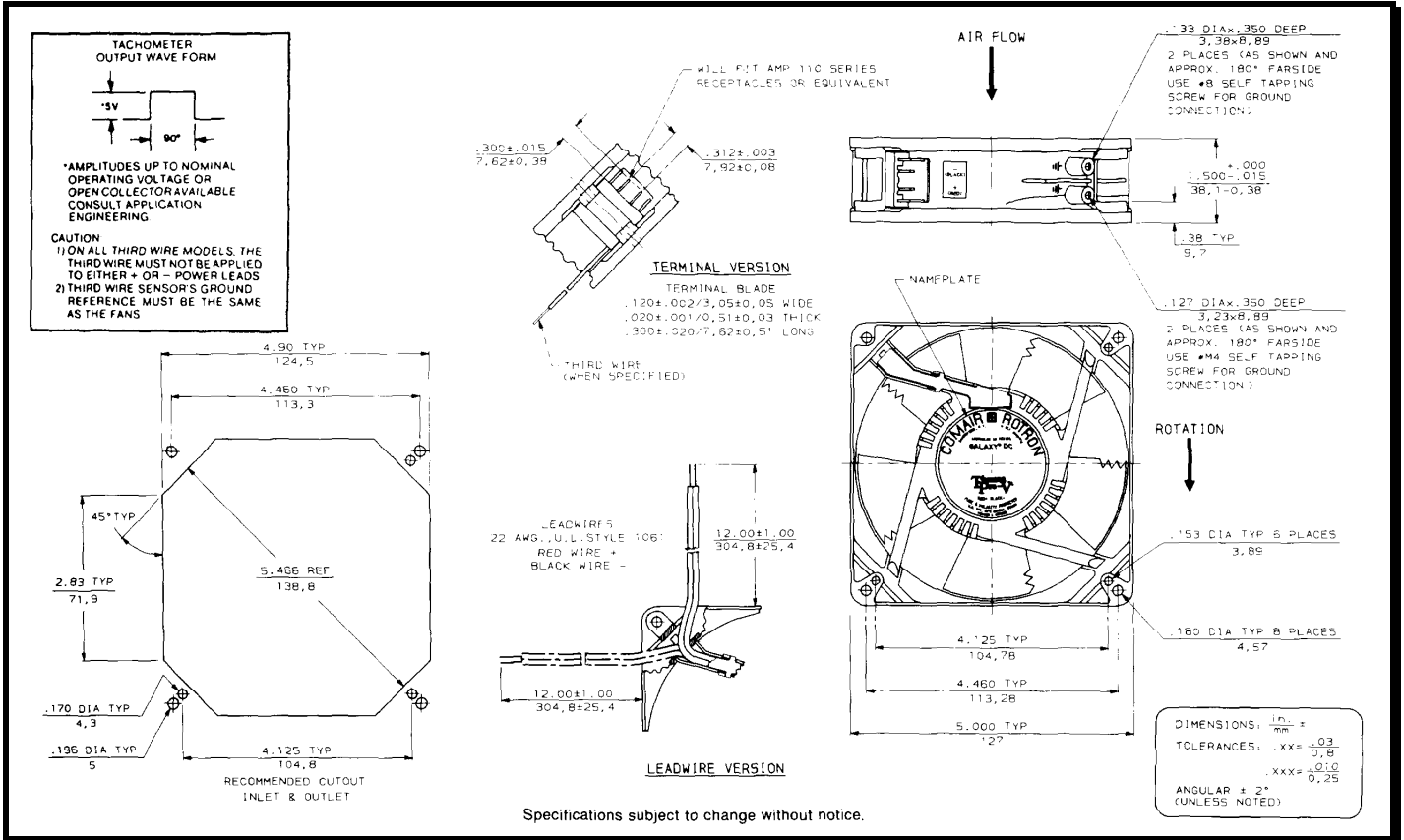

Motor:

Nominal Voltage = 48 vdc
 Operating Voltage Range = 24 - 56 vdc
 Nominal Running Current = 0.31 amps
 Locked Rotor Current = 0.93 amps
 Running Power = 15.0 watts
 Average Speed = 3200 rpm
 Bearings = Ball
 Air Flow = 144 CFM
 Acoustic = 53.6 dBA

Construction:

Venturi: Die Cast Aluminum, Black
 Propeller: Plastic, Black, UL 94V-0

Agency Certifications:

UL, CE

Life Expectancy:

This fan is designed for continuous duty life of 80,000 hours at 50°C.

Additional Features:

Brushless DC Motor
 Locked Rotor Protection
 Reverse Polarity Protected
 Operating Temperature: -10°C to 70°C
 Storage Temperature: -40°C to 85°C

Tachometer Output:

Output: 5 volt TTL
 I_c : 5 mA Typical
 Pulses Per Revolution: 2
 Isolated: No

Termination:

12" Lead wires, 22 AWG, UL 1061
 Red = Power (+)
 Black = Ground (-)
 Blue/White = Tachometer (Output)