

HIGH POWER PULSED FIBER SOURCES

Features

- Peak powers up to 10 kW
- Average output power from 20 mW to 1 W
- Output wavelengths of 1064, 1085, or 1550nm
- Adjustable pulse durations, repetition rates
- Gaussian beam profiles
- Compact, air cooled package
- Maintenance free operation
- High electrical-to-optical efficiency
- RS232 and USB control interfaces, GPIB optional
- High performance-to-cost ratio
- Custom design flexibility

Applications

- Spectroscopy
- Lidar
- Range finding
- Nonlinear Optics
- Free-Space communication
- Material processing
- R&D

Preliminary

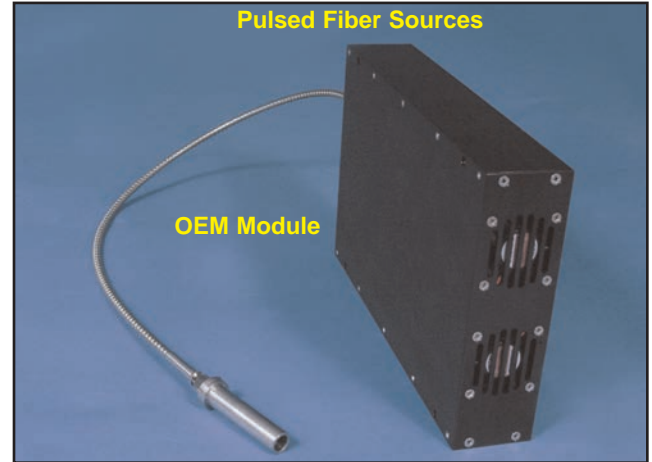

OZ Optics' Pulsed Fiber Sources (PFS) are a series of compact turnkey systems or OEM modules based on a highly reliable master-oscillator/power-amplifier (MOPA) design, to deliver multi-kilowatt level peak powers with average output powers of up to 1 W. The all-fiber configuration provides a robust, monolithic design with no optical parts to align or stabilize, and no need for maintenance parts or materials. The sources can operate under high shock, vibration, or dusty conditions. PFS systems have both RS232 and USB control interfaces plus an optional GPIB interface. External trigger inputs are available to allow you to integrate them into your setup.

Standard Product Specifications:

Parameters	Unit	Value
Average output power ¹	W	0.02 to 1
Peak power	kW	Up to 2
Wavelength range	nm	1064nm, 1085nm or 1550nm
Pulse width (FWHM)	ns	10 to 100
Repetition rate	kHz	10 to 100
Data input		Standard TTL level input
Operating voltage: (AC or DC)	V	100/120 or 200/240, 50 or 60 Hz AC or +5 to +28 DC
Dimensions	mm	Depends on model
Weight	kg	Depends on model
Cooling Method		forced air
Operating Temperature	°C	0 to +45
Storage Temperature	°C	-30 to +70
Operating Humidity	%	5 to 95, non-condensing

¹ Other output powers available

Safety Features:

Feature	Description
Error interlock input	Disables the laser operation when open, requiring a restart to restore operation.
Remote stop	Disables laser operation when open, without requiring a restart to restore operation.
Remote warning out	Normally closed, opens if either the error interlock or remote stop inputs are opened
Front panel key switch	Key is required to turn on the laser
Power on indicator	Indicates that the source is turned on.
Emission indicator	Indicates laser light is being emitted by the unit.
Error Indicator	On when laser output has been disabled by any internal or external error condition.

Ordering Standard Parts:

Bar Code	Part Number	Description
TBD	PFS-1-1064/2-S-C-3AS-1-1-10/100-10/100-RU	Bench top 1064nm Pulsed Fiber Source with 1W average output power via a collimated singlemode armored cable. The pulse width is adjustable from 10ns to 100ns and the pulse repetition rate is adjustable from 10kHz to 100kHz. The unit includes RS232 and USB control interfaces as well as external trigger inputs.
TBD	PFS-1-1085/2-S-C-3AS-1-1-10/100-10/100-RU	Bench top 1085nm Pulsed Fiber Source with 1W average output power via a collimated singlemode armored cable. The pulse width is adjustable from 10ns to 100ns and the pulse repetition rate is adjustable from 10kHz to 100kHz. The unit includes RS232 and USB control interfaces as well as external trigger inputs.
TBD	PFS-1-1550/2-S-C-3AS-1-1-10/100-10/100-RU	Bench top 1550nm Pulsed Fiber Source with 1W average output power via a collimated singlemode armored cable. The pulse width is adjustable from 10ns to 100ns and the pulse repetition rate is adjustable from 10kHz to 100kHz. The unit includes RS232 and USB control interfaces as well as external trigger inputs.

Ordering Information For Custom Parts:

OZ Optics welcomes the opportunity to provide custom designed products to meet your application needs. As with most manufacturers, customized products do take additional effort so please expect some differences in the pricing compared to our standard parts list. In particular, we will need additional time to prepare a comprehensive quotation, and lead times will be longer than normal. In certain cases non-recurring engineering (NRE) charges, lot charges, and/or a minimum order will be necessary. These points will be carefully explained in your quotation, so your decision will be as well-informed as possible.

Description

Pulsed Fiber Source

N = Package style

- 1 for Bench Top unit
- 2 for 19" Rack mount
- 3 for OEM Module

WT = Output Wavelength and tolerance in nanometers

F = Fiber type:

- S = Singlemode fiber

X = Connector Type:

- F for Focuser
- C for Collimator

Note: Contact OZ for information on available collimator or focuser options, or for other types of connectors

Part Number
PFS-N-W/T-F-X-JD-L-P-PW-R-I

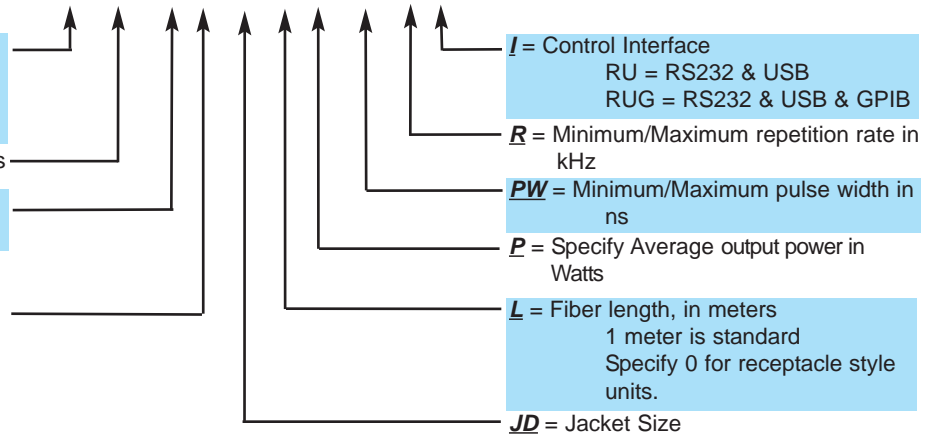

See table 7 of the standard tables for other jacket sizes.

Standard Accessories:

Bar Code	Part Name	Description
2737	POWER CORD - EUROPE	European power cord
2736	POWER CORD - UK	UK power cord