

DATASHEET AND OPERATING GUIDE

PLD Series

Laser Diode Drivers



FEATURES AND BENEFITS

- Models: 200 mA, 500 mA, 1.25 A, 5 A, and 6.5 A
- Operates from a 5 VDC supply
- Separate power supply can be used to drive high-compliance lasers up to 28 V
- Constant Current or Constant Power modes
- Safety features protect your laser
 - » Adjustable latching current limit
 - » Slow-start circuitry
 - » Relay shorts output when current is disabled
- Local and Remote Power-On and Enable controls
- Integral heatsink and fan on high current models

RELIABILITY YOU CAN TRUST

The PLD Series Laser Diode Drivers deliver the reliability and performance you expect from a Wavelength Electronics laser driver in a compact and easy-to-integrate package. Tens of thousands of PLD drivers are deployed in particle counters, manufacturing vision systems, wavefront scanners, fiber aligners, and other laser systems around the world, proving beyond doubt the reliability and stability of the design.

DESIGNED FOR EASY INTEGRATION

The PLD drivers operate from a single 5 V power supply. To accommodate high compliance lasers, or multiple stacked lasers, the PLD laser diode drivers allow the laser to be driven from a separate power supply up to 30 V.

LASER SAFETY FEATURES

Built-in safety features make your product more robust to real world operating conditions: latching current limit switches off the output if the current limit is reached; slow start circuit ramps the output current; and a mechanical shorting relay protects the laser from ESD events. Long-term reliability means better up-time, fewer service calls, and more customers who are satisfied with your products.

HIGH OUTPUT CURRENT

The PLD Series is available up to 12.5 A drive current. Check our website, or call and ask for information about the PLD10000 and PLD12500.

CONTENTS

	PAGE
QUICK CONNECT GUIDE	2
PIN DESCRIPTIONS	5
ELECTRICAL SPECIFICATIONS	6
SAFETY INFORMATION	7
OPERATING INSTRUCTIONS	8
ADDITIONAL TECHNICAL INFORMATION	14
TROUBLESHOOTING	19
MECHANICAL SPECIFICATIONS	20
CERTIFICATION AND WARRANTY	21

ORDERING INFORMATION

PART NO	DESCRIPTION
PLD200	200 mA Laser Diode Driver
PLD500	500 mA Laser Diode Driver
PLD1250	1.25 A Laser Diode Driver
PLD5000	5.0 A Laser Diode Driver
PLD6500	6.5 A Laser Diode Driver
PLDEVAL	Evaluation board for PCB-mounted PLD drivers

QUICK CONNECT GUIDE



TO ENSURE SAFE OPERATION OF THE PLD DRIVER, IT IS IMPERATIVE THAT YOU DETERMINE THAT THE UNIT WILL BE OPERATING WITHIN THE INTERNAL HEAT DISSIPATION SAFE OPERATING AREA (SOA).

Visit the Wavelength Electronics website for the most accurate, up-to-date, and easy to use SOA calculator:

www.teamwavelength.com/support/design-tools/soa-ld-calculator

Figure 1 shows the front panel of the PLD driver and the locations of the configuration switches, Output and Current Limit adjust trimpots, status LEDs, and pins.

Figure 2 shows a typical wiring diagram for the PLD driver and external electronics to operate a Type A or B laser.

Figure 3 illustrates the three laser types that the PLD can drive. For detailed instructions on using the different laser types refer to the **Operating Instructions**.

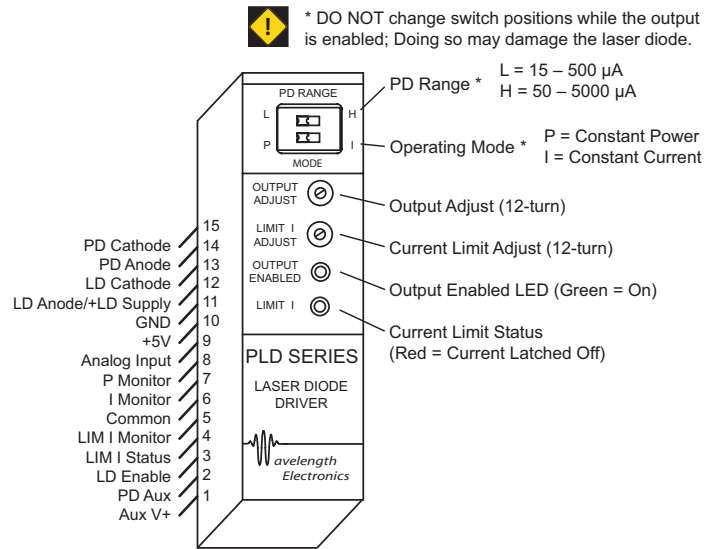

Figure 1. PLD Driver Controls

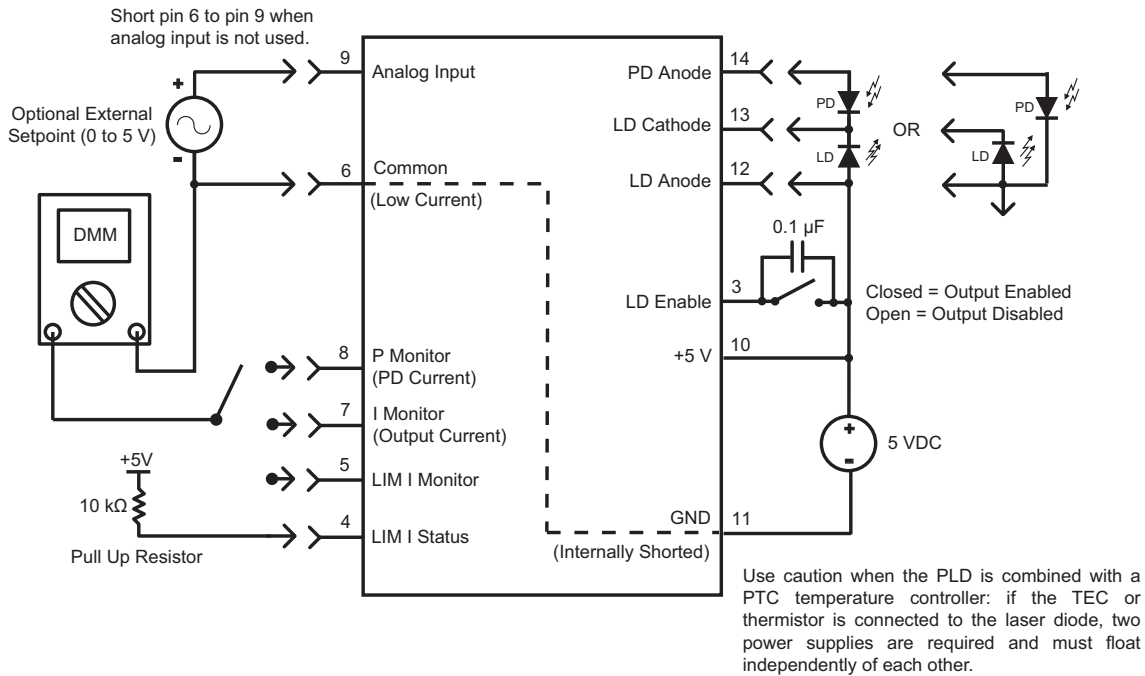

Figure 2. Quick Connect Wiring Diagram, Type A & B Laser Diodes

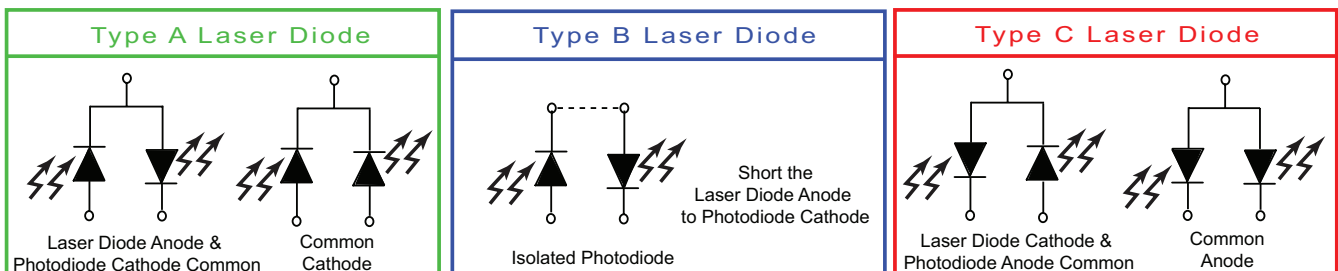

Figure 3. Laser Type Diagrams

QUICK CONNECT GUIDE, CONTINUED

CONSTANT CURRENT TEST LOAD

We recommend using a test load to configure the PLD; refer to **Figure 4**. When using the test load, the actual drive current can be determined by measuring the voltage drop across the resistor. Do not place an ammeter in series with the load circuit.

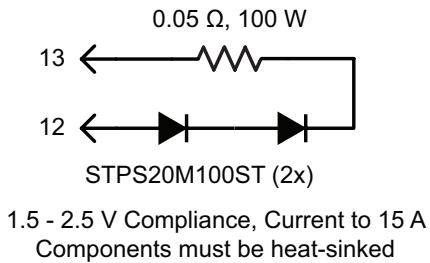
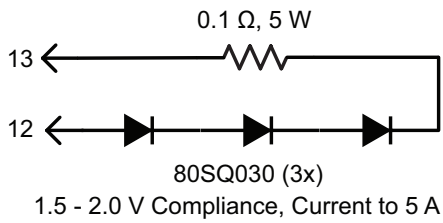
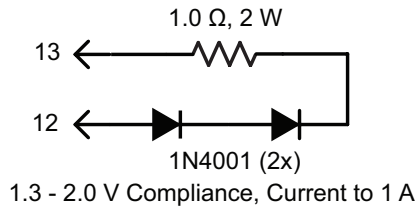

Figure 4. Constant Current Mode Laser Test Loads

QUICK CONNECT GUIDE, CONTINUED

CONSTANT POWER TEST LOADS

These loads are intended to operate at around 500-750 μ A of photodiode current at a laser diode drive current of approximately 50% of the maximum laser diode current for each model of PLD.

To achieve this the circuit components must be changed specific to each PLD model. The following table shows the component values that should be used.

The R_E resistor will typically produce a load voltage of 2.25 V to 4.25 V, depending on the PLD model being used. Adjust R_L to change the compliance voltage of the load and change R_E to adjust the “sensitivity” of the simulated photodiode.

PLD MODEL	R_L (Ω)	V_{R_L} (V)	R_E (Ω)	D1, D2	$V_{PIN12-PIN13}$ (V)
PLD200	12	1.2	1.2K	1N4001	2.56
PLD500	6	1.5	1.2K	1N4001	2.86
PLD1250	2	1.25	1.2K	80SQ035	2.25
PLD5000	1	2.5	3.65K	80SQ035	3.5
PLD6500	1	3.25	5.1K	80SQ035	4.25

Figure 5 illustrates a test load that can be used to operate the PLD in Constant Power mode to simulate use with type A/B lasers.

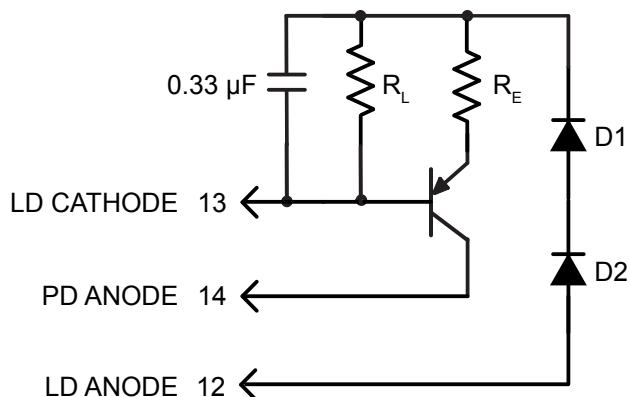
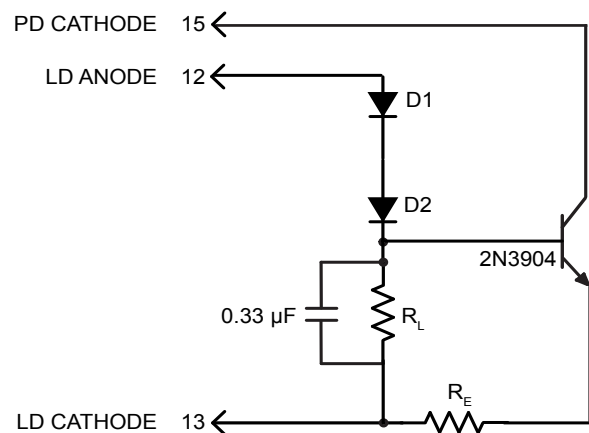

Figure 5. Constant Power Mode Test Load, Type A/B Lasers

Figure 6 illustrates a test load that can be used to operate the PLD in Constant Power mode to simulate use with a type C laser.

The PLD series can operate in Constant Power mode assuming that the user provides a PD auxiliary supply voltage (PDAUX) separate from the laser diode power supply. The PDAUX voltage must be approximately 2 V greater than the LD supply voltage.



NOTE: Jumper PD Aux (pin 2) and PDA (pin 14)

Figure 6. Constant Power Mode Test Load, Type C Lasers

PIN DESCRIPTIONS

Table 1. Pin Descriptions

PIN	NAME	PIN DESCRIPTION
1	Aux V+	For TYPE C Laser Diodes only. See Figure 11 on page 11 .
2	PD Aux	For TYPE C Laser Diodes only. See Figure 11 .
3	LD Enable	Output Enable. Disable = ground or floating. Enable = 3 to 5 V. Requires 5 mA input current. Not TTL-compatible.
4	LIM I Status	Status output pin. Indicates if the driver has reached current limit and has switched off the output. Signal is < 0.3 V if the driver is in limit and output is latched off. Signal is high impedance during normal operation. Toggle LD Enable to reset the limit circuit and enable the output current.
5	LIM I Monitor	Current Limit Monitor. Transfer function varies by model—refer to Table 2 . Range 0 to 2.5 V. Impedance 1 kΩ. The current limit voltage should be set 0.2 V above the desired limit level. Instructions for fine-tuning the current limit are on page 14 .
6	Common	Measurement ground. Low current return used only with Monitor pins and Analog Input. Internally shorted to GND (pin 11).
7	I Monitor	Laser Diode Output Current Monitor. Transfer function varies by model—refer to Table 2 . Range 0 to 2.5 V. Impedance 1 kΩ. NOTE: I Monitor signal has artificial 20 mV offset. Subtract 20 mV for accurate reading.
8	P Monitor	Photodiode Current Monitor (power monitor). Transfer function varies by PD feedback range setting—refer to Table 2 . Range 0 to 2.5 V. Impedance 1 kΩ.
9	Analog Input	Remote setpoint or modulation input. Transfer function varies by model and operating mode—refer to Table 2 . Range 0 to 5 V. Impedance 1 MΩ. Not TTL-compatible. Connect Analog Input pin to Common (pin 6) when not using the Analog Input function. The Analog Input signal sums with the onboard setpoint value. See Electrical Specifications for damage threshold information.
10	+5 V	Supply voltage to control electronics. Range 4.5 to 5.5 VDC. If using a single supply, the power supply must be rated to source at least 1.1-times the laser current plus the PLD quiescent current.
11	GND	Power supply ground. Used with +5 V for high current return.
12	LD Anode / +LD Supply	Laser Diode Anode connection. Also used as power supply input for high-compliance lasers. Maximum input voltage 30 VDC.
13	LD Cathode	Laser Diode Cathode connection.
14	PD Anode	Photodiode Anode connection only for Type A & B lasers. Tie this pin to PD Aux (pin 2) for Type C lasers; see Figure 11 on page 11 .
15	PD Cathode	Photodiode Cathode connection only for Type C lasers. See Figure 11 .

Table 2. Current Output Monitor, Limit Monitor, Photodiode Current Monitor, and Analog Input Transfer Functions

FUNCTION	MODE	PLD200	PLD500	PLD1250	PLD5000	PLD6500
LIM I Monitor (Current Limit)	CC / CP	80 mA / V	200 mA / V	500 mA / V	2 A / V	2.6 A / V
I Monitor (Output Current)	CC / CP	80 mA / V	200 mA / V	500 mA / V	2 A / V	2.6 A / V
Analog Input; CC-Mode	CC	40 mA / V	100 mA / V	250 mA / V	1 A / V	1.3 A / V
P Monitor (Photodiode Current); Low Range	CC / CP	200 μA / V				
P Monitor (Photodiode Current); High Range <small>See Note</small>	CC / CP	2 mA / V				
Analog Input CP-Mode; Low Range	CP	100 μA / V				
Analog Input, CP-Mode; High Range <small>See Note</small>	CP	1 mA / V				

Note: High Range is not available when using Type C Lasers.

ELECTRICAL SPECIFICATIONS

PARAMETER	SYMBOL	MIN	TYP	MAX	UNIT	NOTE
ABSOLUTE MAXIMUM RATINGS						
Supply Voltage	+5 V	5.0 to 5.5			VDC	
Supply Voltage, LDA High Compliance	LD Anode	3.0 to 30			VDC	Consult Safe Operating Area calculator for supply voltages > 5 VDC; see page 18 .
Supply Voltage, Type C Lasers	Aux V+	8.0 to 12.5			VDC	
Operating Temperature Range	T _{OPR}	0 to 50			°C	
Storage Temperature Range	T _{STG}	-55 to 125			°C	
Weight		< 0.3			lbs	
Size					in	
PLD200		1.52 x 2.65 x 0.81				38.6 mm x 67.3 mm x 20.6 mm
PLD500		1.52 x 2.65 x 1.10				38.6 mm x 67.3 mm x 27.9 mm
PLD1250, PLD5000, PLD6500		1.52 x 2.65 x 1.82				38.6 mm x 67.3 mm x 46.3 mm

PARAMETER	MODEL					UNIT
	PLD200	PLD500	PLD1250	PLD5000	PLD6500	
DRIVE CURRENT OUTPUT						
Max Internal power Dissipation	3	9	45	45	45	W
Max Output Current	0.2	0.5	1.25	5.0 ¹	6.5 ¹	A
Compliance Voltage	3 V max with 5 VDC power supply voltage 28 V max with 30 VDC power supply voltage					V
Short Term Stability, 1 hour	< 100	< 100	< 100	< 200	< 200	ppm
Quiescent Current	50	50	250	250	250	mA
Temperature Coefficient	< 200					ppm / °C
Leakage Current	0					mA

PHOTODIODE FEEDBACK						
High Range	50 – 5000					µA
Low Range, Type A & B Lasers Only	15 – 500					µA
Constant Power Mode Output Stability	< 0.02					%

EXTERNAL MODULATION						
Analog Input Damage Threshold	(V _{IN} < -0.5) or V _{IN} > (0.5 V above Supply Voltage on Pin 10)					V
Input Pin Impedance	1					MΩ
3 dB Bandwidth, Constant Current ² , max current	190	200	200	140	100	kHz
Depth of Modulation at 100 kHz ³	90					%
Rise / Fall Time	5 / 3	5 / 3	5 / 3	4 / 3	12 / 5	µsec

TIMING CHARACTERISTICS^{4,5}						
Output Turn-On Delay	≥1.5					seconds
Slowstart Output On-Time	250					msec
Disable Fall Time	>100					µsec

MONITOR ACCURACY						
Monitor Voltage vs. Expected Output based on transfer function	2					% of Full Scale

- In order to drive full current to the laser, the supply voltage may need to be increased to 5.5 V to compensate for voltage drop across the cables at high current.
- Modulation bandwidth in Constant Power mode will depend on the photodiode frequency response. Photodiode specifications vary widely from one manufacturer to another, but the bandwidth in CP mode is typically 10% of the Constant Current bandwidth.
- Peak-to-Peak output amplitude decreases as frequency increases; see figure at right.
- See **page 17** for timing graphs.
- See **page 16** for PLD Revision F timing characteristics.

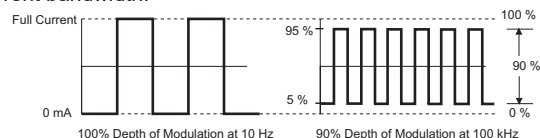

SAFETY INFORMATION

SAFE OPERATING AREA – DO NOT EXCEED INTERNAL POWER DISSIPATION LIMITS

Before attempting to operate the PLD driver, it is imperative that you first determine that the unit will operate within the *Safe Operating Area* (SOA). Operating outside of the SOA may damage the laser and the PLD. Operating outside of the SOA will void the warranty.

To determine if the PLD driver is suitable for your application and if it will be operating in the safe range, consult the instructions for calculating the Safe Operating Area on-line:

www.teamwavelength.com/support/design-tools/soa-ld-calculator

SOA charts are included in this datasheet for quick reference (**page 18**), but we recommend you use the on-line tools instead.



TO ENSURE SAFE OPERATION OF THE PLD DRIVER, IT IS IMPERATIVE THAT YOU DETERMINE IF THE UNIT IS GOING TO BE OPERATING WITHIN THE INTERNAL HEAT DISSIPATION SAFE OPERATING AREA (SOA).

If you have any questions about the Safe Operating Area calculator, call the factory for free and prompt technical assistance.

THEORY OF OPERATION

The PLD Series drivers are controlled current sources: they deliver the current commanded by the setpoint. The current source continually monitors the actual output current, compares it to the setpoint, and adjusts the current if there is a difference between the two signals.

It may be useful to remember that you do not directly set the drive current setpoint; instead, you adjust a voltage signal that represents the output current. The voltage and output current are related by a transfer function that varies by driver model number.

The setpoint voltage is adjusted with the onboard trimpot or by an external input that sums with the onboard setpoint. The adjustable current limit is set in a similar manner.

As current is driven through the load, there is a voltage drop across the load because of the impedance. As the current increases, the voltage drop may increase to the point that it reaches the Compliance Voltage limit of the current source. Once that occurs, the current source is no longer able to increase the current driven to the load even if you increase the setpoint.

The PLD driver includes features that help protect your laser and make the driver more versatile in a wide array of applications:

- The user-adjustable latching current limit protects the laser from over-current situations by switching off the output when a limit condition is detected. Toggling the Enable resets the current limit circuit.
- Output current switches on after approximately 1.5 seconds from the time the Enable signal is applied.
- Output slow-start ramps the current to setpoint over 250 msec.
- A mechanical relay shorts the output connections when the output is disabled, and when the PLD driver is powered off.

OPERATING INSTRUCTIONS

The PLD requires minimal external electronics. If you are using the driver on the benchtop or for prototyping your laser control system, we recommend purchasing the PLDEVALPCB board.

The driver is first configured for local control in order to set the drive current limit. Then the driver is reconfigured according to the actual application.

We recommend using a test load until you are familiar with operation of the driver. Refer to **page 3** for test load schematics.

NECESSARY EQUIPMENT

The following equipment is the minimum necessary to configure the PLD for basic operation:

- PLD controller
- PLDEVALPCB evaluation board (recommended)
- Digital voltmeter, 4-½ digit resolution recommended
- Test load for configuring the driver
- Laser diode, mount, and temperature control system
- Connecting wires
- Power supply (see below)

POWER SUPPLY REQUIREMENTS

Linear-regulated or low-noise switching power supplies can be used. We recommend using power supplies with noise specifications suitable for your application.

For single-supply operation:

- 5 VDC power supply rated for 1.1-times the maximum laser diode current, plus 50 – 250 mA for the electronics (see **Electrical Specifications**)

For two-supply operation to drive a high-compliance laser:

- 5 VDC power supply rated for 50 – 250 mA
- Power supply rated for 1.1-times the maximum laser diode drive current and > 2 V greater than the compliance voltage of the laser.

For Type C lasers:

- 8 to 12 VDC power supply rated for 50 – 250 mA, plus 1.1-times the maximum laser diode drive current; power regulation circuitry is also required (see **Figure 10**)
- OR, a 5 VDC power supply for the PLD driver electronics (rated for 50 – 250 mA) and an 8 to 12 VDC power supply for the laser, rated for 1.1-times the maximum laser diode current

SAFE OPERATING AREA AND THERMAL DESIGN CONSIDERATIONS

SOA charts are included in this datasheet for quick reference, but we recommend you use the on-line tools instead.

www.teamwavelength.com/support/design-tools/soa-ld-calculator



IT IS IMPERATIVE THAT YOU VERIFY THE UNIT WILL OPERATE WITHIN THE INTERNAL HEAT DISSIPATION SAFE OPERATING AREA (SOA).

OPERATING THE DRIVER OUTSIDE THE SOA MAY DAMAGE OR DESTROY THE DRIVER AND/OR LASER.

PREVENT DAMAGE FROM ELECTROSTATIC DISCHARGE

Before proceeding, it is critical that you take precautions to prevent electrostatic discharge (ESD) damage to the driver and your laser. ESD damage can result from improper handling of sensitive electronics, and is easily preventable with simple precautions.

Enter the search phrase “[ESD Precautions for Handling Electronics](#)” in an internet search engine to find information on ESD-safe handling practices.

We recommend that you always observe ESD precautions when handling the PLD driver and your laser diode.

INSTALL THE PLD ON THE PLDEVALPCB BOARD

Align the pins on the PLD with the plated holes on the evaluation board, making sure all pins are aligned before seating the PLD on the board.

Insert the 4-40 x 1/4" screw through the bottom of the printed circuit board into the heatsink, and tighten. Solder the PLD pins to the PLDEVALPCB board.

It is essential to mechanically secure the PLD to the circuit board with a 4-40 x 1/4" screw. The electrical pins alone do not provide sufficient mechanical strength to secure the PLD to the circuit board.

The PLD heatsink can be grounded by connecting a wire to the 4-40 mounting screw and then to the chassis or system ground. Grounding the heatsink will reduce the electrical noise generated by the fan on the PLD1250, PLD5000, and PLD6500.

CONFIGURE THE PLDEVALPCB BOARD FOR YOUR APPLICATION

On the PLDEVALPCB evaluation board, configure the two jumper bars. Refer to **Figure 7**.

- **Laser Type-Select Jumper.** Remove the jumper for Type A/B laser operation. Install the jumper to tie pin 14 to pin 2 for Type C laser operation. The factory default configuration is with the jumper removed.
- **LD Power Supply Jumper.** To operate the PLD and laser from a single 5 VDC power supply, install this jumper. If you are operating a high-compliance laser with a separate power supply, remove the jumper. The factory default configuration is with the jumper installed.

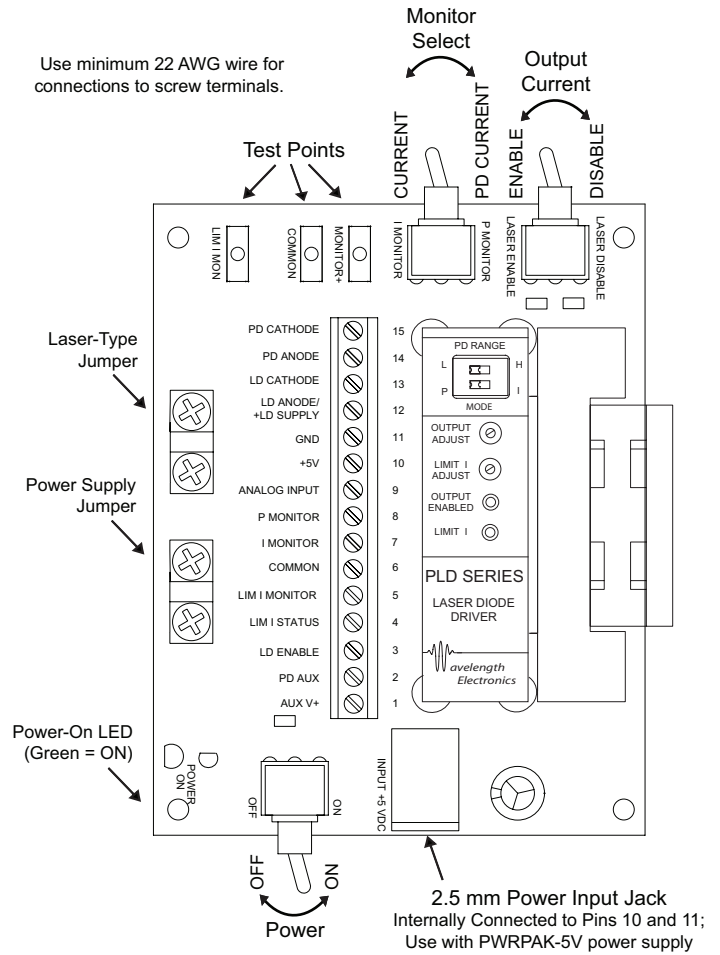

Figure 7. PLDEVALPCB Evaluation Board

WIRE THE PLD LASER DRIVER

Refer to **Table 3** for wiring instructions specific to your configuration. For setup and configuration use a test load. The same wiring instructions apply whether the PLD is used on the PLDEVALPCB board or installed on a circuit board.

Table 3. Wiring Configurations

CONFIGURATION	DIAGRAM
Type A & B Laser Diode, Single 5 VDC Power Supply	Figure 8
Type A & B Laser Diode, High-Compliance Laser Diode	Figure 9
Type A & B Laser Diode, Negative Supply Operation	Figure 10
Type C Laser Diode, Single Power Supply	Figure 11

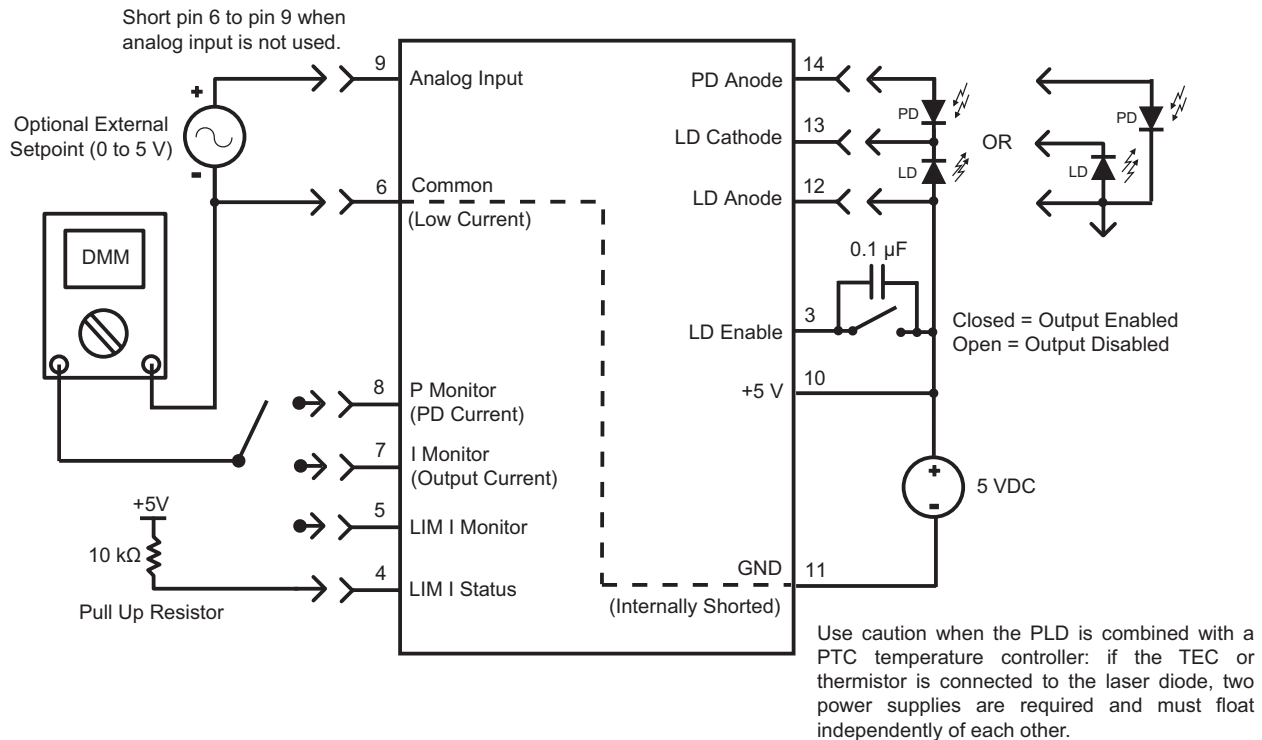

Figure 8. Type A & B Laser Diode, Single 5 VDC Power Supply

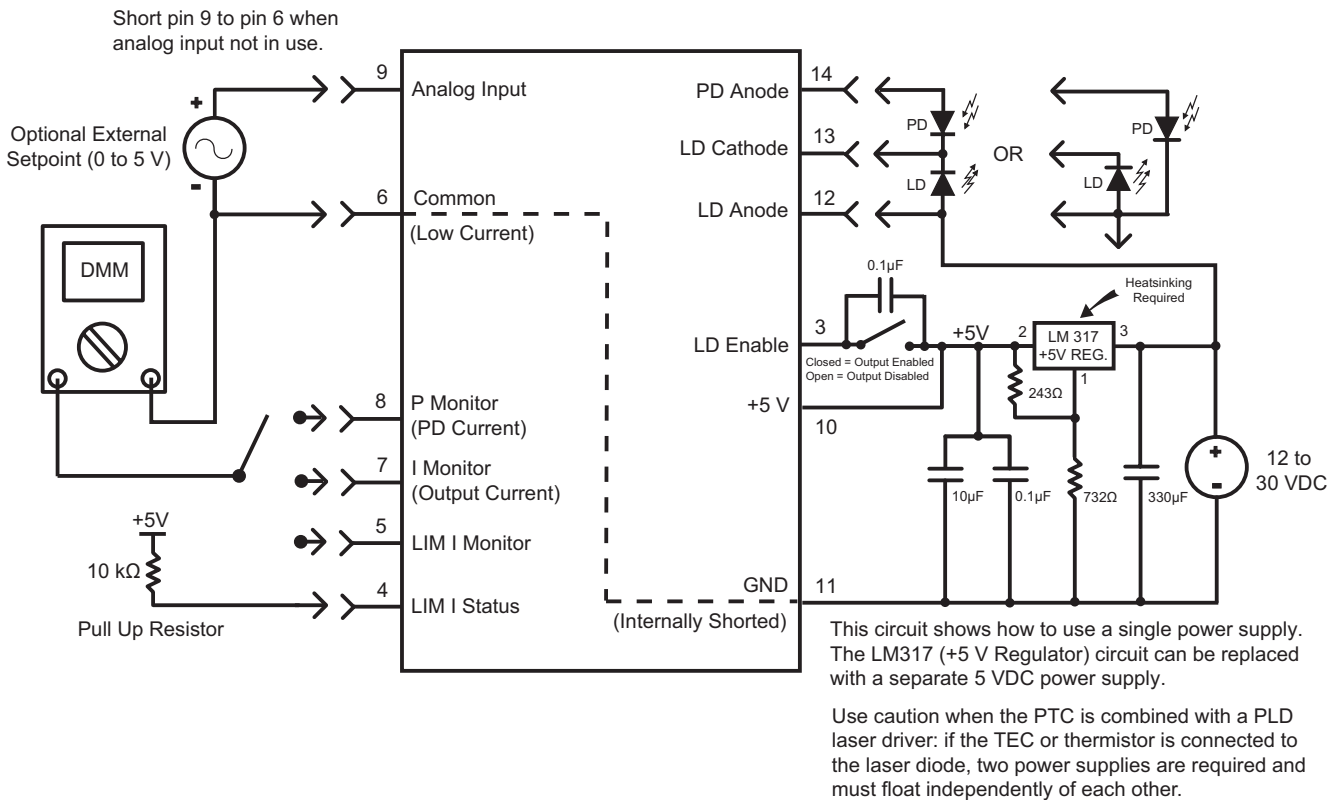

Figure 9. Type A & B Laser Diode, High-Compliance Laser Diode

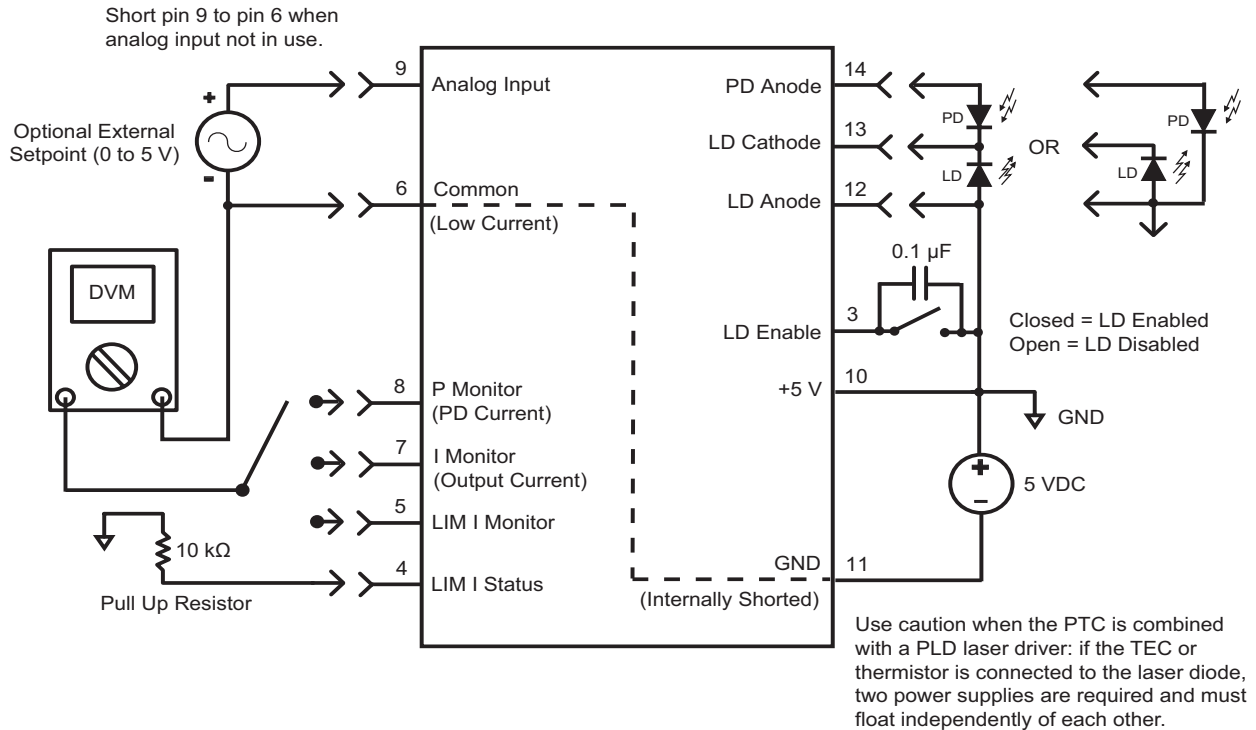

Figure 10. Type A & B Laser Diode, Negative Power Supply Operation

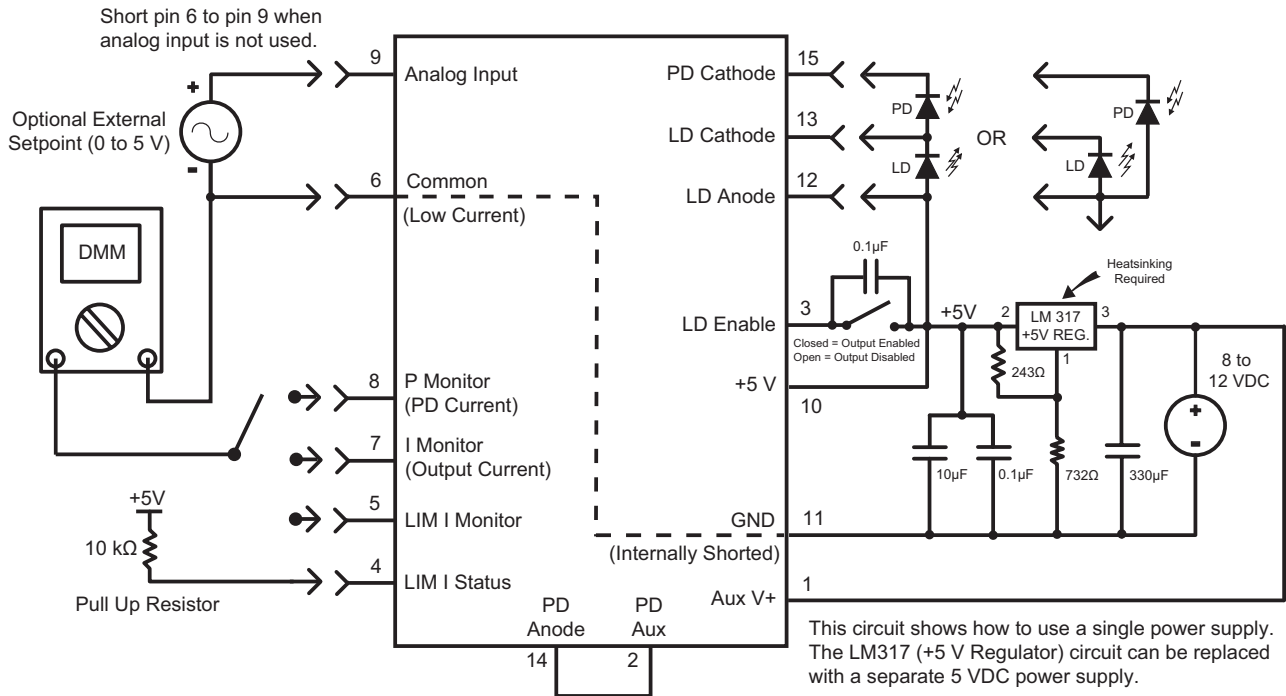

Figure 11. Type C Laser Diode

ONBOARD ADJUSTMENTS AND CONTROLS

Onboard controls are on the top of the PLD and must be set according to the operation mode. The controls are illustrated in **Figure 12**.

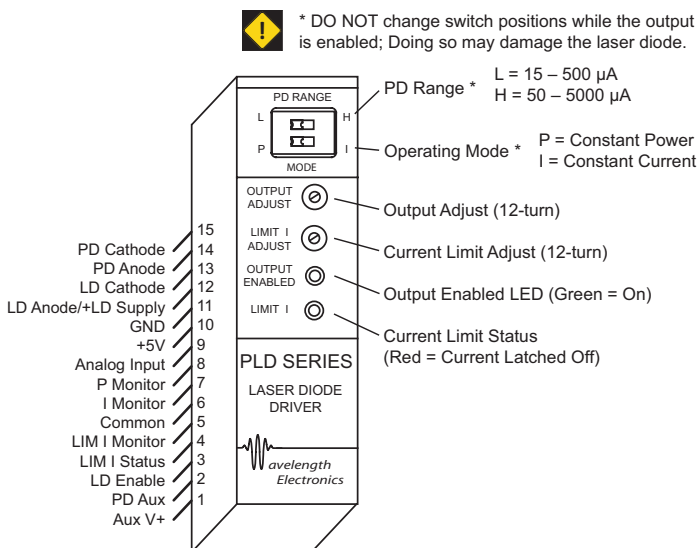

Figure 12. PLD Driver Adjustments and Controls

SET THE CONTROL MODE

Set the MODE switch to P (left) for CP-mode operation, or to I (right) for CC-mode. Constant Power mode operation requires a photodiode feedback loop from the laser diode.



DONOTSWITHTHECONTROLMODEWHILETHEOUTPUTIS ENABLEDANDDRIVINGALASERDIODE.THELASERDIODE MAY BE DAMAGED OR DESTROYED.

SET THE PHOTODIODE RANGE

Two photodiode feedback current ranges are available on the PLD drivers. Reference the datasheet for your laser diode to find the nominal photodiode current, and set the PD RANGE switch as follows:

- L (left) = Low Range, PD current 15 – 500 µA
- H (right) = High range; PD current 50 – 5000 µA



DONOTSWITHTHEPDRANGEWHILETHEOUTPUTIS ENABLEDANDDRIVINGALASERDIODE.THELASERDIODE MAY BE DAMAGED OR DESTROYED.

CALCULATE THE MONITOR VOLTAGES

Refer to the datasheet for your laser to determine the maximum forward current, and calculate the LIM I Monitor voltage using this equation and the transfer function found in **Table 2 on page 5**:

$$V_{LIM\ I\ Mon} = I_{LIMIT} / \text{Transfer Function}$$

If you are using the PLD in Constant Current mode, calculate the monitor voltage for the drive current setpoint. Refer to the datasheet for your laser to determine the nominal forward current, and calculate the I Monitor voltage using the transfer function found in **Table 2**:

$$V_{I_MON} = I_{LD} / \text{Transfer Function}$$

If you are using the PLD in Constant Power mode, calculate the P Monitor voltage. Refer to the laser diode datasheet to determine the nominal photodiode current at the desired operating point. Calculate the P Monitor voltage using the transfer function found in **Table 2**:

$$V_{P_MON} = I_{PD} / \text{Transfer Function}$$

SET THE CURRENT LIMIT

Connect the positive lead of the digital voltmeter to the LIM I Monitor terminal or evaluation board test point, and the negative lead to the COMMON terminal.

Reference **Figure 7** for switch and control locations on the PLDEVALPCB board. Configure the PLD and PLDEVALPCB board:

- Set the OUTPUT switch to LASER DISABLE
- Set the POWER switch to ON
- Set the MONITOR switch to I MONITOR
- Set the OUTPUT ADJUST trimpot to zero by turning at least 12 turns counter-clockwise.
- Set the current limit by turning the LIMIT I ADJUST trimpot until the voltage displayed on the multimeter matches the value calculated above.

Switch off power on the evaluation board, then switch off the power supply.

The PLD controllers trip the current limit circuit below the expected limit level, by 0.2 V on the monitor. To trip the current limit at exactly the desired current level, refer to **Set the Current Limit More Accurately on page 14** to fine-tune the current limit.

ADJUST THE OUTPUT CURRENT SETPOINT— ONBOARD CONTROL

To increase the output current, turn the onboard trimpot clockwise; turn counter-clockwise to decrease output current.

While adjusting the output current, measure the voltage on pin 7, I Monitor. Use the transfer function listed in **Table 2** to determine the output current from the monitor voltage.

ADJUST THE OUTPUT CURRENT SETPOINT— ANALOG INPUT

To use the Analog Input on pin 9 to adjust the output current, refer to Pin Descriptions on **page 5** for specifications. The analog input signal sums with the onboard trimpot value.

Refer to the External Setpoint Circuit on **page 15** for an example analog input circuit. Other circuits, a DAC signal, or function generator may be used.

COMBINING THE ONBOARD SETPOINT AND ANALOG INPUT

The Analog Input voltage signal on pin 9 sums with the onboard trimpot setpoint. This configuration allows the driver to be configured so that the laser current or power modulates around a DC setpoint.

If the sum of the two signals causes the PLD to attempt to drive the output current past the limit, the output will switch off and indicate a current limit error.

To avoid driving the current to the limit, first set the onboard trimpot to produce the Constant Current level. Then connect the modulation source to the Analog Input pin and slowly increase the modulation amplitude. Monitor the output current using the I Monitor pin, or by measuring the voltage across the test load. Do not monitor the voltage across a laser diode—measurement transients may damage the laser diode.

CURRENT LIMIT CIRCUIT TRIGGER AND RESET

If the PLD detects current limit, the output will switch off and the LIMIT I LED on the top of the unit will illuminate red. Set the Enable switch to OFF, correct the cause of the error, and then re-enable the output. Toggling the Output Current switch on the PLDEVALPCB board will clear the current limit latch.

ADDITIONAL TECHNICAL INFORMATION

This section includes useful technical information on these topics:

- Remote Limit Status LED Circuit
- Set the Current Limit More Accurately
- Change the Photodiode Range, Type A & B Lasers
- Change the Photodiode Range, Type C Lasers
- Change the Analog Input Modulation Transfer Function
- External Setpoint Circuit
-
- Ground the Fan on the PLD1250, PLD5000, and PLD6500
- Fine Tune Deep Modulation
- Cable Lengths and High Current
- Add Laser Diode Protection for Long Cables
- Additional Noise Filtering
- Monitor Calibration Circuit
- Revision F Timing Characteristics
- Product Variations
- Output On/Off and Current Limit Timing
- Safe Operating Area Calculation

REMOTE LIMIT STATUS LED CIRCUIT

The LIM I Status feature can be used to drive a remote LED up to 15 mA in your control system. Connect the LED as shown in **Figure 13**.

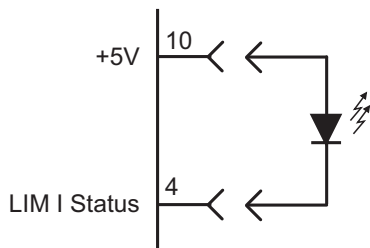

Figure 13. Remote LIM I Status LED

SET THE CURRENT LIMIT MORE ACCURATELY

The current limit circuit is designed with a small hysteresis, which causes the limit circuit to trip at a slightly lower current than calculated. To fine-tune the current limit, a small offset voltage must be factored in. Use this equation to calculate the hysteresis offset, where V_{+5V} is the supply voltage:

$$\text{Offset (V)} = (V_{+5V} - V_{I_MON}) / 25.9$$

Then add the Offset to V_{LIMIT} calculated on **page 12**.

CHANGE THE PHOTODIODE RANGE, TYPE A & B LASERS

The photodiode current range and transfer function can be adjusted by adding an external resistor. This feature is useful when the photodiode current of your laser falls in a range that does not allow maximum measurement sensitivity on the PLD driver.

Figure 14 shows the internal resistor network of the PLD and the equations explain the interaction with the external resistor.

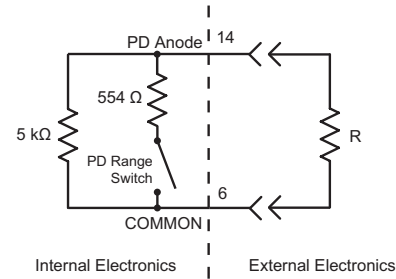

PD Range = L	PD Range = H
Range = $\frac{2.5 \text{ V} * 10^6}{R \parallel 5 \text{ k}\Omega} \mu\text{A}$	Range = $\frac{2.5 \text{ V} * 10^6}{R \parallel 500 \Omega} \mu\text{A}$
Transfer Function = $\frac{10^6}{R \parallel 5 \text{ k}\Omega} \mu\text{A} / \text{V}$	Transfer Function = $\frac{10^6}{R \parallel 500 \Omega} \mu\text{A} / \text{V}$
$R \parallel 5 \text{ k}\Omega = \frac{R * 5000}{R + 5000} \Omega$	$R \parallel 500 \Omega = \frac{R * 500}{R + 500} \Omega$

Figure 14. Adjusting the PD Range, Type A & B Lasers

CHANGE THE PHOTODIODE RANGE, TYPE C LASERS

The photodiode range and transfer function can be adjusted when using Type C lasers by connecting a ¼ W resistor between the PD Cathode (pin 15) and AUX V+ (pin 1).

The PD current range is calculated (units are amps):

$$\text{Range} = 2.5 \text{ V} / (R \parallel 5 \text{ k}\Omega)$$

The transfer function is calculated (units are A / V):

$$\text{Transfer Function} = 1 / (R \parallel 5 \text{ k}\Omega)$$

The value of $(R \parallel 5 \text{ k}\Omega)$ is calculated as follows (units are Ω):

$$(R \parallel 5 \text{ k}\Omega) = (R * 5000) / (R + 5000)$$

CHANGE THE ANALOG INPUT MODULATION TRANSFER FUNCTION

The Analog Input modulation transfer function can be changed by adding a voltage divider resistor network external to the PLD driver. **Figure 15** illustrates a simple circuit.

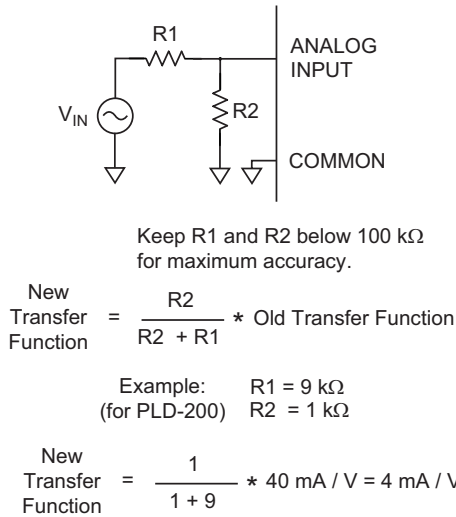
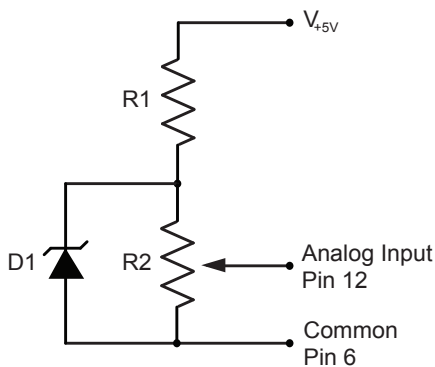

Figure 15. Changing the Analog Input Modulation Transfer Function

EXTERNAL SETPOINT CIRCUIT

An external trimpot circuit can be used to adjust the laser current setpoint; refer to **Figure 16**.



V_{+5V} = Supply voltage (5 to 30 V)
 D1 = Bandgap reference * (LM4040D50)
 R1 = 2.2 kΩ, 1 W resistor
 R2 = Trimpot, 10 kΩ to 100 kΩ

* V_{+5V} must be at least 1 volt greater than the voltage value of D1.

* Use an LM4040-2.5 with a +5 V supply for a 0 to 2.5 V external setpoint signal

Figure 16. Trimpot Circuit for Analog Input

IMPORTANT INFORMATION ON GROUNDING

Some laser diodes connect the laser anode or cathode to the case. In such cases special attention must be paid to grounding to ensure safe operation of the PLD and laser.



IT IS CRITICAL THAT THE PLD DRIVER IS PROPERLY GROUNDED. IF THE PLD DRIVER IS USED WITH A WAVELENGTH ELECTRONIC TEMPERATURE CONTROLLER, YOU MAY NEED TO USE TWO SEPARATE POWER SUPPLIES THAT FLOAT INDEPENDENTLY OF EACH OTHER.

If the laser anode is connected to the laser case, it is possible that the anode will be connected to earth ground when the laser is installed in a benchtop mount or in your laser system. In situations where the laser diode is connected to the case, it is critical that the negative terminal of the power supply remain isolated from earth ground.

GROUND THE FAN ON THE PLD1250, PLD5000, AND PLD6500

The PLD1250, PLD5000, and PLD6500 models are equipped with a fan that cools the heatsink. The fan in some cases may create electrical noise. To reduce the electrical noise level you must connect the heatsink to earth/chassis ground or the system ground (power supply common). To ground the heatsink you need to connect ground to the tapped hole in the bottom of the heatsink.

FINE TUNE DEEP MODULATION

If the analog modulation input is near the rail (>4.5 V), output current signal response may be insufficient. Performance may be improved by connecting a quality low-ESR 330 μF, 16 V electrolytic capacitor between the power terminals (pins 10 and 11). This decoupling capacitor should be directly connected at the driver.

CABLE LENGTHS AND HIGH CURRENT

The length and gauge of cable from the power supply or to the laser diode can impact performance. The resistance and inductance of the wire can reduce bandwidth or cause the voltage to the PLD to droop.

If the output current starts to oscillate as setpoint voltage approaches the limit setting, then the power supply cables may be too long. If you cannot shorten the cables, place a 330 μF capacitor across pins 10 and 11 to minimize droop. Always twist the wire pairs to eliminate reactance.

ADD LASER DIODE PROTECTION FOR LONG CABLES

With a cable longer than two feet, add a Schottky diode across the laser diode, see **Figure 17**.

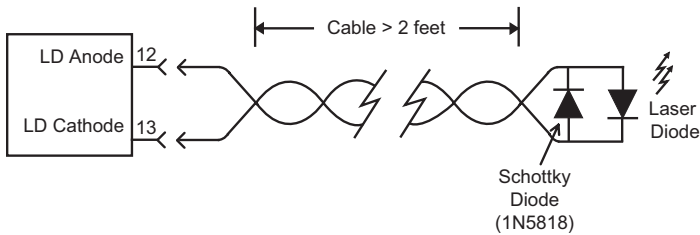

Figure 17. Long Cable Laser Protection

ADDITIONAL NOISE FILTERING

The PLD drivers provide low-noise current to the laser diode, but in some cases additional filtering may be needed. Refer to **Figure 18** for a simple and effective filter.

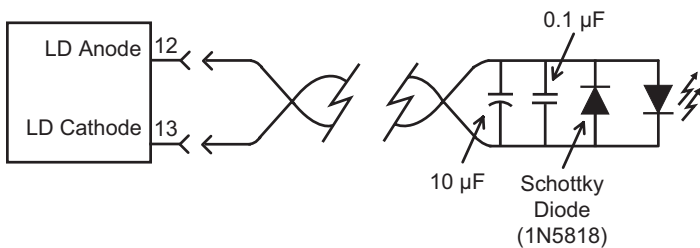

Figure 18. PLD Output Filter

MONITOR CALIBRATION CIRCUIT

A small offset may be present when measuring the P Monitor, I Monitor or LIM I Monitor voltage with respect to the actual output. Use the circuit shown in **Figure 19** to remove any offset.

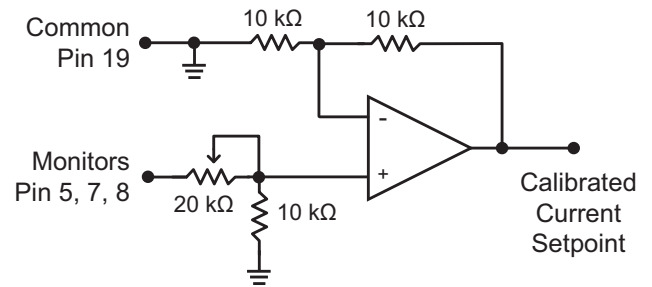

Figure 19. Monitor Calibration Circuit

REVISION F TIMING CHARACTERISTICS

Table 4 and **Table 5** describe the timing and bandwidth characteristics of the PLD Series Revision F units.

Table 4. Output Timing, Revision F

TURN-ON TIME	TURN-OFF TIME	SLOWSTART DELAY
6.8 μsec	6.8 μsec	≥ 1.5 sec

Table 5. Output Bandwidth, Revision F

MODEL	BANDWIDTH
PLD200	65 kHz
PLD500	100 kHz
PLD1250	100 kHz
PLD5000	100 kHz

PRODUCT VARIATIONS

We design and manufacture our products in-house, and that gives us the unique ability to modify our drivers and controllers to suit your application. Our Product Variation service allows us to quickly and cost-effectively address your design requests, from prototype quantities to long-term high-volume manufacturing.

Examples of past Product Variations include:

- Increasing the compliance voltage limit
- Replacing current limit trimpots with fixed-value resistors to maximize long-term stability in an OEM laser controller system
- Optimizing heatsink size and configuration to fit within the space constraints of your electronics chassis
- Changing the controller input voltage

OUTPUT ON/OFF AND CURRENT LIMIT TIMING

Figure 20 through Figure 22 illustrate the output turn-on delay, slowstart turn-on/off time, and current limit response.

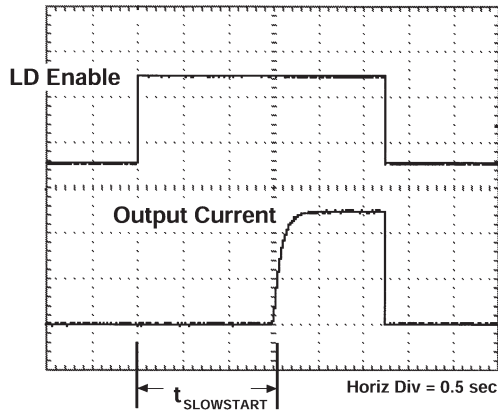

Figure 20. Output Turn-On Delay

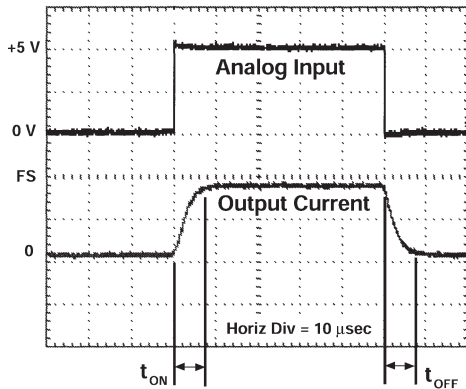

Figure 21. Slowstart Output On/Off-Time

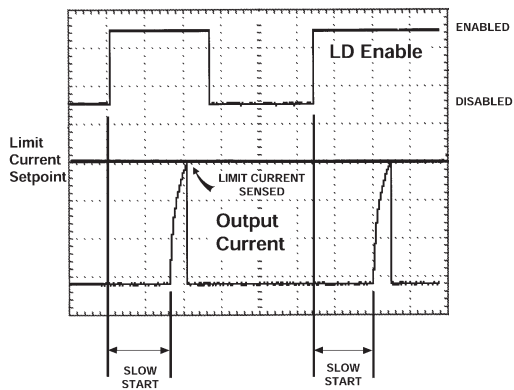

Figure 22. Current Limit Response

SAFE OPERATING AREA CALCULATION

The Safe Operating Area of the PLD driver is determined by the amount of power that can be dissipated within the output stage of driver. If that power limit is exceeded permanent damage can result.



DO NOT OPERATE THE PLD DRIVER OUTSIDE OF THE SAFE OPERATING AREA CURVE.

OPERATING THE PLD DRIVER OUTSIDE OF THE SOA VOIDS THE WARRANTY.

Refer to the Wavelength Electronics website for the most up-to-date SOA calculator for our products. The on-line tool is fast and easy to use, and also takes into consideration operating temperature.

www.teamwavelength.com/support/design-tools/soa-ld-calculator

SOA charts are included in this datasheet for quick reference, however we recommend you use the on-line tools instead.

Follow these steps to determine if the driver will be operating within the SOA.

- Refer to the laser diode datasheet to find the maximum voltage (V_{MAX}) and current (I_{MAX}) specifications
- Calculate the voltage drop across the controller:

$$V_{DROP} = V_S - V_{MAX} \quad (V_S \text{ is the power supply voltage})$$

- Mark V_{DROP} on the X-axis, and extend a line upward
- Mark I_{MAX} on the Y-axis, and extend a line to the right until it intersects the V_{DROP} line
- On the X-axis, mark value of the V_S
- Extend a diagonal line from V_S to the intersection of the V_{DROP} and I_{MAX} lines; this is the Load Line
- If the Load Line crosses the Safe Operating Area line at any point, the configuration is not safe

If the SOA Calculator indicates the PLD will be outside of the Safe Operating Area, the system must be changed so that less power is dissipated within the driver. See Wavelength Electronics Application Note [AN-LDTC01: The Principle of the Safe Operating Area](#) for information on shifting the Load Line.

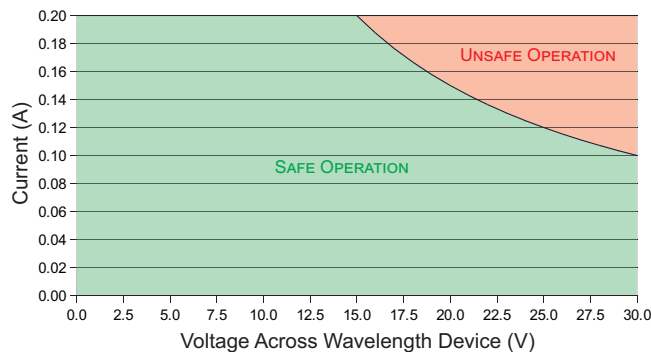

Figure 23. SOA for PLD200

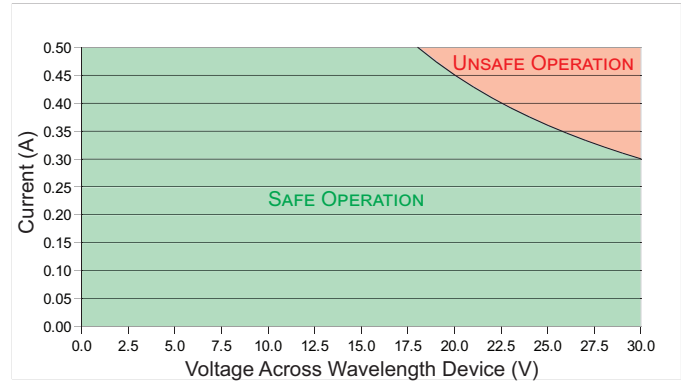

Figure 24. SOA for PLD500

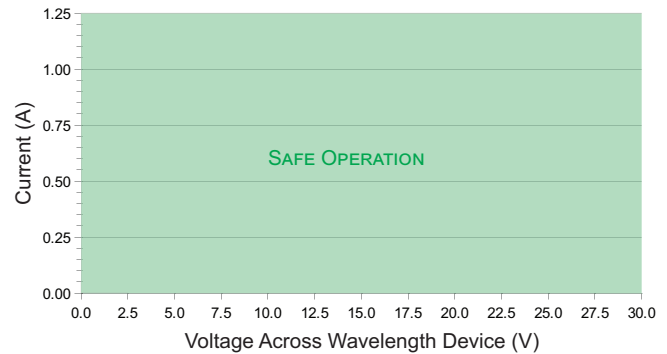

Figure 25. SOA for PLD1250

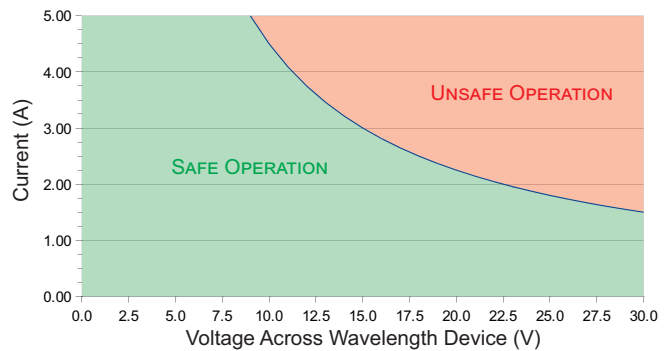

Figure 26. SOA for PLD5000

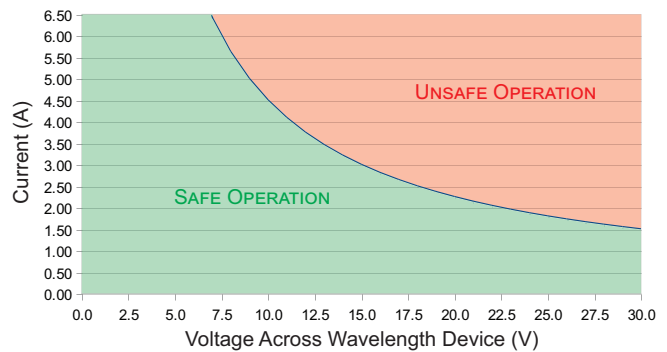

Figure 27. SOA for PLD6500

TROUBLESHOOTING

PROBLEM	POTENTIAL CAUSES	SOLUTIONS
Driver will not switch on	Improperly configured power supply	Carefully check the wiring diagram according to Table 3 .
Output will not enable	Remote Enable signal is not correct	Refer to the LD Enable specifications in Table 1 and make sure your input enable signal is correct.
Laser output power too low in Constant Current mode	Laser current setpoint too low	Increase the setpoint either by adjusting the I SET trimpot clockwise, or by increasing the signal voltage on the Analog Input (pin 9).
	Laser current limit too low	Refer to page 12 for instructions on setting the laser driver current limit.
	Laser driver is compliance limited	Check the laser diode specifications to determine the forward voltage (V_f). Make sure that the PLD is not compliance limited. Refer to the Electrical Specifications table on page 6 . If the driver is compliance limited, $V_{LD\ ANODE}$ may need to be increased. Verify that the PLD will be operating within the Safe Operating Area if $V_{LD\ ANODE}$ is increased.
Laser does not reach desired output in Constant Power mode	Current limit too low	Check the laser diode datasheet to determine the approximate laser drive current at the desired optical power output level. Then verify that the current limit is set slightly higher than that. See page 12 for instructions on setting the laser driver current limit.
	Photodiode feedback current is out of range for the PLD	Refer to the laser diode datasheet to determine the approximate photodiode (PD) current at the desired output power level. If the PD current exceeds the PLD PD current range, set the PD Range switch to High Range; see page 12 .

MECHANICAL SPECIFICATIONS

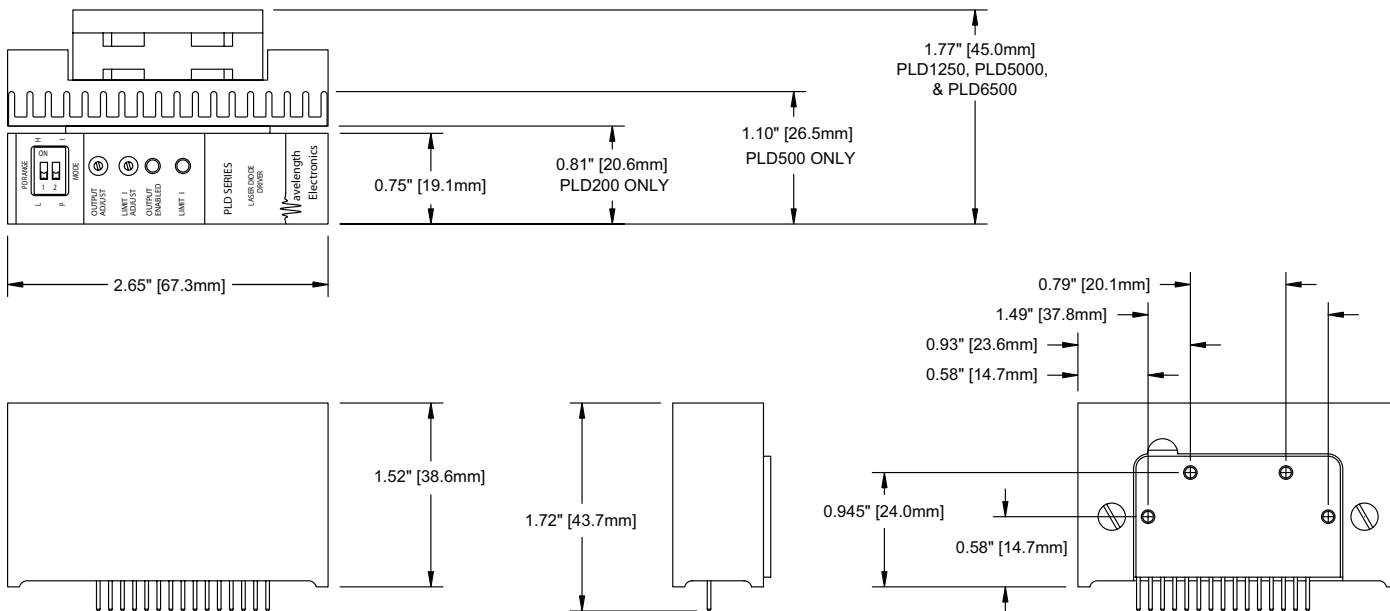

Figure 28. PLD Driver Mechanical Dimensions

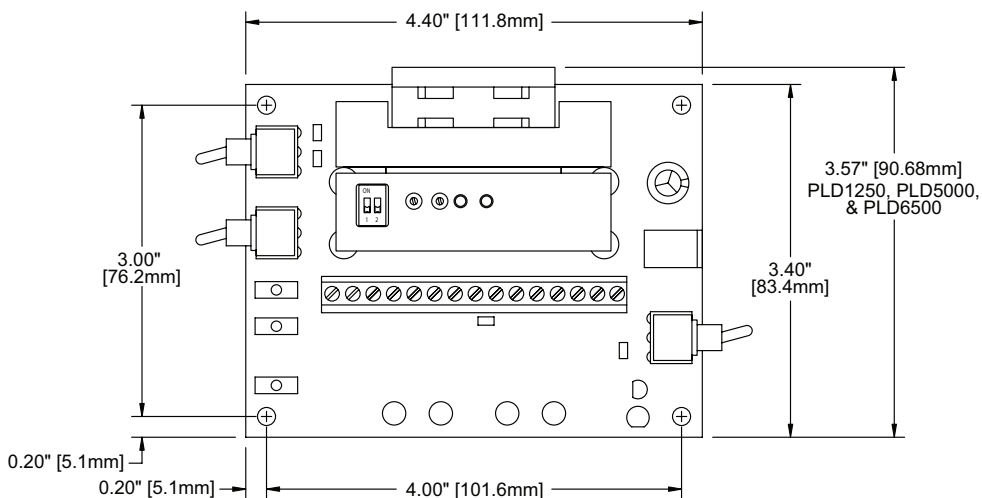

Figure 29. PLDEVALPCB Board Mechanical Dimensions

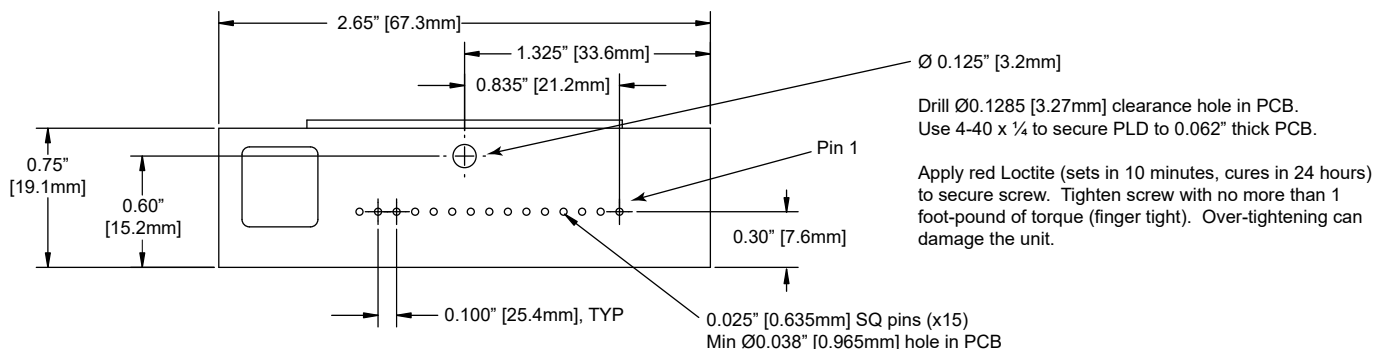

Figure 30. PLD PCB Layout Pattern, Top View
All Tolerances $\pm 5\%$; units in inches [mm]

CERTIFICATION AND WARRANTY

CERTIFICATION

Wavelength Electronics, Inc. (Wavelength) certifies that this product met its published specifications at the time of shipment. Wavelength further certifies that its calibration measurements are traceable to the United States National Institute of Standards and Technology, to the extent allowed by that organization's calibration facilities, and to the calibration facilities of other International Standards Organization members.

WARRANTY

This Wavelength product is warranted against defects in materials and workmanship for a period of one (1) year from date of shipment. During the warranty period, Wavelength will, at its option, either repair or replace products which prove to be defective.

WARRANTY SERVICE

For warranty service or repair, this product must be returned to the factory. An RMA is required for products returned to Wavelength for warranty service. The Buyer shall prepay shipping charges to Wavelength and Wavelength shall pay shipping charges to return the product to the Buyer upon determination of defective materials or workmanship. However, the Buyer shall pay all shipping charges, duties, and taxes for products returned to Wavelength from another country.

LIMITATIONS OF WARRANTY

The warranty shall not apply to defects resulting from improper use or misuse of the product or operation outside published specifications. No other warranty is expressed or implied. Wavelength specifically disclaims the implied warranties of merchantability and fitness for a particular purpose.

EXCLUSIVE REMEDIES

The remedies provided herein are the Buyer's sole and exclusive remedies. Wavelength shall not be liable for any direct, indirect, special, incidental, or consequential damages, whether based on contract, tort, or any other legal theory.

REVERSE ENGINEERING PROHIBITED

Buyer, End-User, or Third-Party Reseller are expressly prohibited from reverse engineering, decompiling, or disassembling this product.

NOTICE

The information contained in this document is subject to change without notice. Wavelength will not be liable for errors contained herein or for incidental or consequential damages in connection with the furnishing, performance, or use of this material. No part of this document may be translated to another language without the prior written consent of Wavelength.

SAFETY

There are no user-serviceable parts inside this product. Return the product to Wavelength Electronics for service and repair to ensure that safety features are maintained.

LIFE SUPPORT POLICY

This important safety information applies to all Wavelength electrical and electronic products and accessories:

As a general policy, Wavelength Electronics, Inc. does not recommend the use of any of its products in life support applications where the failure or malfunction of the Wavelength product can be reasonably expected to cause failure of the life support device or to significantly affect its safety or effectiveness. Wavelength will not knowingly sell its products for use in such applications unless it receives written assurances satisfactory to Wavelength that the risks of injury or damage have been minimized, the customer assumes all such risks, and there is no product liability for Wavelength. Examples of devices considered to be life support devices are neonatal oxygen analyzers, nerve stimulators (for any use), auto-transfusion devices, blood pumps, defibrillators, arrhythmia detectors and alarms, pacemakers, hemodialysis systems, peritoneal dialysis systems, ventilators of all types, and infusion pumps as well as other devices designated as "critical" by the FDA. The above are representative examples only and are not intended to be conclusive or exclusive of any other life support device.

REVISION HISTORY

DOCUMENT NUMBER: PLD5000-00400

REV.	DATE	CHANGE
P	November 2013	Added CE icon and extended warranty
Q	January 2014	Updated CP test load section
R	October 2015	Added Disable Fall Time specification



**WAVELENGTH
ELECTRONICS**