

BeamOn U3 High Power



USB 3.0

Integrated Filter Wheel

Advanced software features

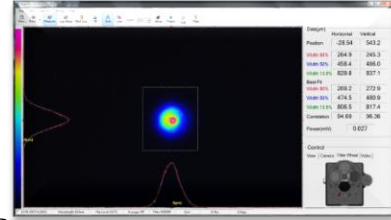

Innovative High Power Beam Profiler (1/1.2") based on advanced beam sampling in conjunction with high resolution camera

Measurement capability of a few kWatts laser power

Specifications

Laser Type	CW & Pulsed
Beam width resolution	1 micron or better
Beam Size	ø75 µm - ø6 mm
Spectral Response	350 – 1310 nm
Resolution (H x V pixels)	1920 x 1200
Sensor Active Area (mm)	11.34 x 7.13
Gain Control	x24
Dynamic Range	60 dB , 12 bit
Exposure Speed	39 µsec to 20 sec
Frame Rate	40 fps (8 bit)
Working Distance	49 mm (contact factory)
Maximum BPP	Max. input angle – 25 deg.
Maximum power density	1,000,000 W/cm ² (contact factory)
Power measuring	With user's pre-calibration at a selected point
Power range @900/1070 nm	CW 1-2500 W, Pulsed 1 – 1000 W
Output power from back side of beam sampler	90% of input power. The Beam Sampler directs only a small portion of laser power for detector measurements. Most of the power exits according to drawing.

Versatile – Measures Profile, Power and Position

Cooling conditions	Filtered pressurized air of 6-8 Bar
Sensor type	CMOS – 1/1.2" format
Beam width accuracy	±1.5%
Power accuracy	±5%
Position resolution	1 µm
Pixel Size	5.86 µm x 5.86 µm
Pixel Bit Depth	8/12 bits
Background Subtraction	User activated
Trigger	<ul style="list-style-type: none"> Internal Software Hardware Falling or Rising Edge Trigger Delay 0.015ms - 4.0 sec
Power Requirements	~2 Watt (Via USB 3.0 interface)
Dimensions (L x W x H) in mm	64 x 103 x 73.5
Weight (typical)	350 gr.
Min. Hardware Requirements	CPU i3 1.6 GHz, 4 GB RAM
Interface	USB 3.0, Windows 7/8/10 (32 & 64 bit)
Mechanical Interface	Post mounting: 2 concentric opposite 8-32 UNC, 6 mm depth
Operating Temperature	0° – 35° C

Ordering Information

Model BeamOn U3HP- VIS NIR: A camera for 350 – 1310 nm with motorized built-in filter wheel with a set of 3xND filters in housing, beam sampler with filter drawer, USB3.0 cable, software and user manual on Flash Drive, carrying case.

*Standard drop-in filter is Hot Mirror, allowing visible light to pass through.

INPUT BEAM

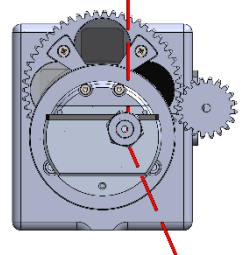

RESIDUAL OUTPUT BEAM (~92%)

BeamOn U3 High Power

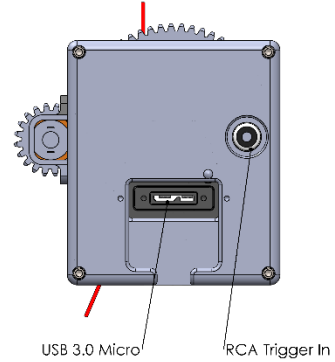
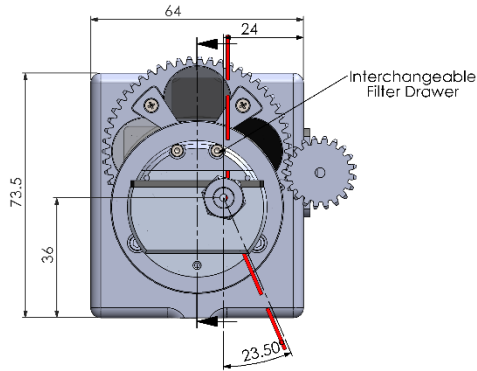
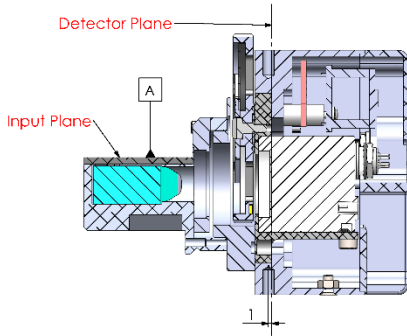

Optical distance from Input plane **A** to Detector Plane: 49 ± 0.5

Warning: For focused beams, Focal Point must be at least 30 mm after input plane **A** (towards the sensor).

Focusing on input optics will damage the optical system!

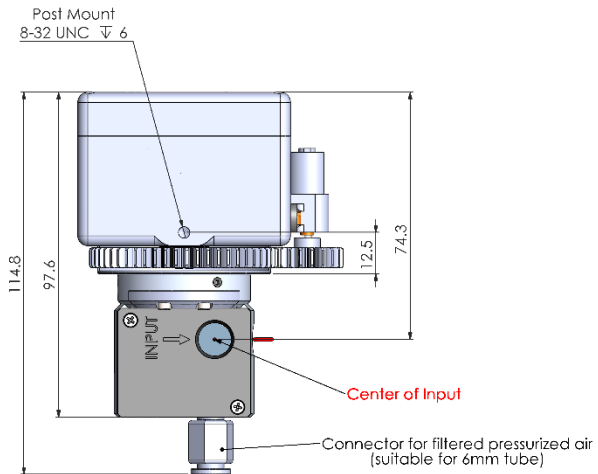

Dimensions are in mm.



info@amstechnologies.com
www.amstechnologies-webshop.com



DUMA OPTRONICS LTD.

Website: <http://www.dumaoptronics.com>

E-mail: sales@duma.co.il

January 2020

