

SSF213 SERIES

MINIATURE INTERNAL FITTING HORIZONTAL SWITCH

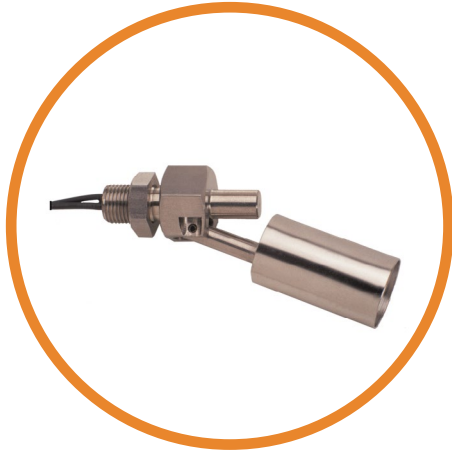

The SSF213 is a miniature horizontally mounted switch that is fitted internally in the side of the tank, so requires access to the inside of the tank.

The total length inside the tank is 54.5mm.

The device is manufactured in SS 304 and will work in liquids of SG 0.8 minimum.

The switch action can be reversed by mounting the device with the float able to move upwards away from the body, instead of the more normal downwards direction.

Features

- Short reach, miniature switch
- Internal mount via 1/8" BSP
- Stainless steel 304
- User configurable N/O (make on rise) or N/C (make on fall)
- Signal switching only

SPECIFICATIONS

Technical

Mounting Style	Internal
Mounting Thread	1/8" BSP
Float & Stem Material	304 grade SS
Maximum Temperature	120°C
Maximum Pressure	5 bar
Float SG	0.7
Minimum Fluid SG	0.8
Cable Length - Standard	50cm
Cable Size	17/0.10 - AWG22
Cable Conductor Material	Tinned copper
Cable Sheath Material	XLPE
Cable Temperature Rating	125°C
Sealing Gasket	Not supplied
Tightening Torque for Fixing Nut	2.0kg/cm

Electrical

Contact Form		N/O or N/C
Switching Power Max	VA	1
Switching Voltage AC Max	V	24
Switching Voltage DC Max	V	24
Switching Current Max	A	0.1

All ratings are for resistive load only.

STANDARD PARTS

	Material	Max Power	Leadouts
SSF213T050	SS 304	1VA	50cm XLPE 17/0.1

Custom versions can be made for particular applications. Please contact Sensata with your requirements.

DIMENSIONS

All dimensions are in millimeters.

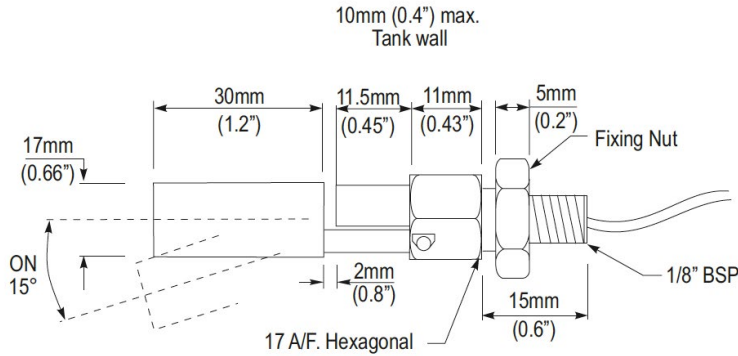

Distributor



amstechnologies

where technologies meet solutions

info@amstechnologies.com
www.amstechnologies-webshop.com

Contact us

Made in the UK

Page 2

Sensata Technologies, Inc. ("Sensata") data sheets are solely intended to assist designers ("Buyers") who are developing systems that incorporate Sensata products (also referred to herein as "components"). Buyer understands and agrees that Buyer remains responsible for using its independent analysis, evaluation and judgment in designing Buyer's systems and products. Sensata data sheets have been created using standard laboratory conditions and engineering practices. Sensata has not conducted any testing other than that specifically described in the published documentation for a particular data sheet. Sensata may make corrections, enhancements, improvements and other changes to its data sheets or components without notice.

Buyers are authorized to use Sensata data sheets with the Sensata component(s) identified in each particular data sheet. HOWEVER, NO OTHER LICENSE, EXPRESS OR IMPLIED, BY ESTOPPEL OR OTHERWISE TO ANY OTHER SENSATA INTELLECTUAL PROPERTY RIGHT, AND NO LICENSE TO ANY THIRD PARTY TECHNOLOGY OR INTELLECTUAL PROPERTY RIGHT, IS GRANTED HEREIN. SENSATA DATA SHEETS ARE PROVIDED "AS IS". SENSATA MAKES NO WARRANTIES OR REPRESENTATIONS WITH REGARD TO THE DATA SHEETS OR USE OF THE DATA SHEETS, EXPRESS, IMPLIED OR STATUTORY, INCLUDING ACCURACY OR COMPLETENESS. SENSATA DISCLAIMS ANY WARRANTY OF TITLE AND ANY IMPLIED WARRANTIES OF MERCHANTABILITY, FITNESS FOR A PARTICULAR PURPOSE, QUIET ENJOYMENT, QUIET POSSESSION, AND NON-INFRINGEMENT OF ANY THIRD PARTY INTELLECTUAL PROPERTY RIGHTS WITH REGARD TO SENSATA DATA SHEETS OR USE THEREOF.

All products are sold subject to Sensata's terms and conditions of sale supplied at www.sensata.com SENSATA ASSUMES NO LIABILITY FOR APPLICATIONS ASSISTANCE OR THE DESIGN OF BUYERS' PRODUCTS. BUYER ACKNOWLEDGES AND AGREES THAT IT IS SOLELY RESPONSIBLE FOR COMPLIANCE WITH ALL LEGAL, REGULATORY AND SAFETY-RELATED REQUIREMENTS CONCERNING ITS PRODUCTS, AND ANY USE OF SENSATA COMPONENTS IN ITS APPLICATIONS, NOTWITHSTANDING ANY APPLICATIONS-RELATED INFORMATION OR SUPPORT THAT MAY BE PROVIDED BY SENSATA.

Mailing Address: Sensata Technologies, Inc., 529 Pleasant Street, Attleboro, MA 02703, USA.