



## **FIBER OPTIC MEMS SWITCH**

for Specialty Fibers  
or Polarisation-Maintaining  
Fibers



### **OVERVIEW**

The **sercalo** *sn* series are opto-mechanical switches for the most demanding applications in fiber optic sensor systems and instrumentation. The switch is available in 1x1, 1x2, 2x2 and 1x4 variants. The switch mechanism is available in either latching or non latching variants and has a very fast response time below 1 ms and below 1.5 dB insertion loss. The single mode switch is available for a number of specialty fibers covering design wavelengths such as 488 nm, 515 nm, 633 nm, 680 nm, 780 nm, 830 nm, 980 nm and 1064 nm. The 1x2 and 2x2 variants can also be made with polarisation maintaining PANDA fibers.

The miniature package withstands rugged environments and is well suited for direct mounting on printed circuit boards. The switch is qualified according to Telcordia GR 1221.

### **FEATURES**

- reliable
- specialty fibers
- 1.5 dB insertion loss
- 1 ms response time
- low PDL
- 60 dB crosstalk
- miniature size
- 2x2, 2x1, 1x1 variants

### **APPLICATIONS**

- Instrumentation
- Source selection

#### **CONTACT:**

Sercalo microtechnology ltd  
Landstrasse 151, 9494 Schaan  
Principality of Liechtenstein  
Tel. +423 237 57 97 Fax. +423 237 57 48  
www.sercalo.com e-mail: [info@sercalo.com](mailto:info@sercalo.com)

## DESCRIPTION

The **sercalo** switches are composed of an optical subsystem and an electrical driver interface. The optical switching function is realised by a silicon MEMS chip. In the latching *SL* variants, a bistable suspension mechanism keeps the last selected state in power off. In the non-latching *SN* variants, the switch returns into the bar state when electrical power is removed.

To operate the switch 5V and 0V are applied on the supply pins, which are used by the internal DC-DC converter to supply a high voltage for the actuator control. CMOS or TTL logic levels on the control pins switch the high voltage on the electrostatic actuator. To set the switch state in the *latching variant*, pin 2 respectively pin 3 are set to logic high (5V) for 10 ms and the corresponding switch state is selected. At rest pins 3 and 4 should be pulled to 0 V and must not be floating.

In the *non-latching variant* only pin 2 is used to set the state of the switch. To set the cross-state pin 3 must be at logic high. When pin 3 goes to logic low, or at power off, the switch returns into the bar state.

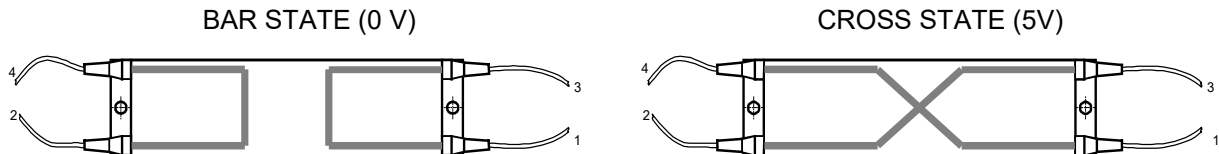

## TECHNICAL SPECIFICATIONS

	Unit	Min	Typ	Max
<b>Switch</b>				
Wavelength Range	nm	Cut off	~Cut Off +200 nm	
Insertion Loss <sup>1</sup>	dB		0.7	1.5
Crosstalk	dB		75	60
Backreflection	dB		55	50
Polarisation Dependent Loss	dB		0.02	0.05
Polarisation Extinction Ratio <sup>2</sup>	dB	18	24	
Repeatability <sup>3</sup>	dB			0.001
Switching Time	ms		0.5	1
Durability	cycles		1 billion	
<b>Package</b>				
Voltage	V	4	5	5.25
Power Consumption	mW		5	10
Operation Temperature	°C	0		70
Storage Temperature	°C	-40		85
Size (L x W x H)	mm		40x16.5x9.5	

<sup>1</sup> for 1x2, 2x2 switch, fibers=5,6,7 excluding connector loss. Fibers 2,3 and 4 = 2 dB max. For 1x4 switch ILmax < 3.0 dB

<sup>2</sup> with Panda fibers for 7 and 9 only.

<sup>3</sup> value for constant temperature and polarisation

## ORDERING INFORMATION

Switch type	State monitor	Variants	Cut Off (design) Wavelength	Polarisation Maintenance
L = latching N = non-latching	- = no monitor TS= position monitor (latching only)	2X2 1X4 (not for PM) 1X2 (no port 4) 1X1 (no ports 4,2)	3 = <450 nm (for 488 and 514 nm) 4 = <600 nm (for 633 and 680 nm) 5 = <750 nm (for 780 nm) 6 = <800 nm (for 830 nm) 7 = <970 nm (for 980, 1064, 1550 nm) 9 = <1250 nm (for 1310 and 1550 nm)	PM=panda fiber, only for 970, 1310, 1550nm - = single mode fiber

**Fibre sleeve type**  
N = loose tube 0.9mm  
B = bare fibre 0.25mm

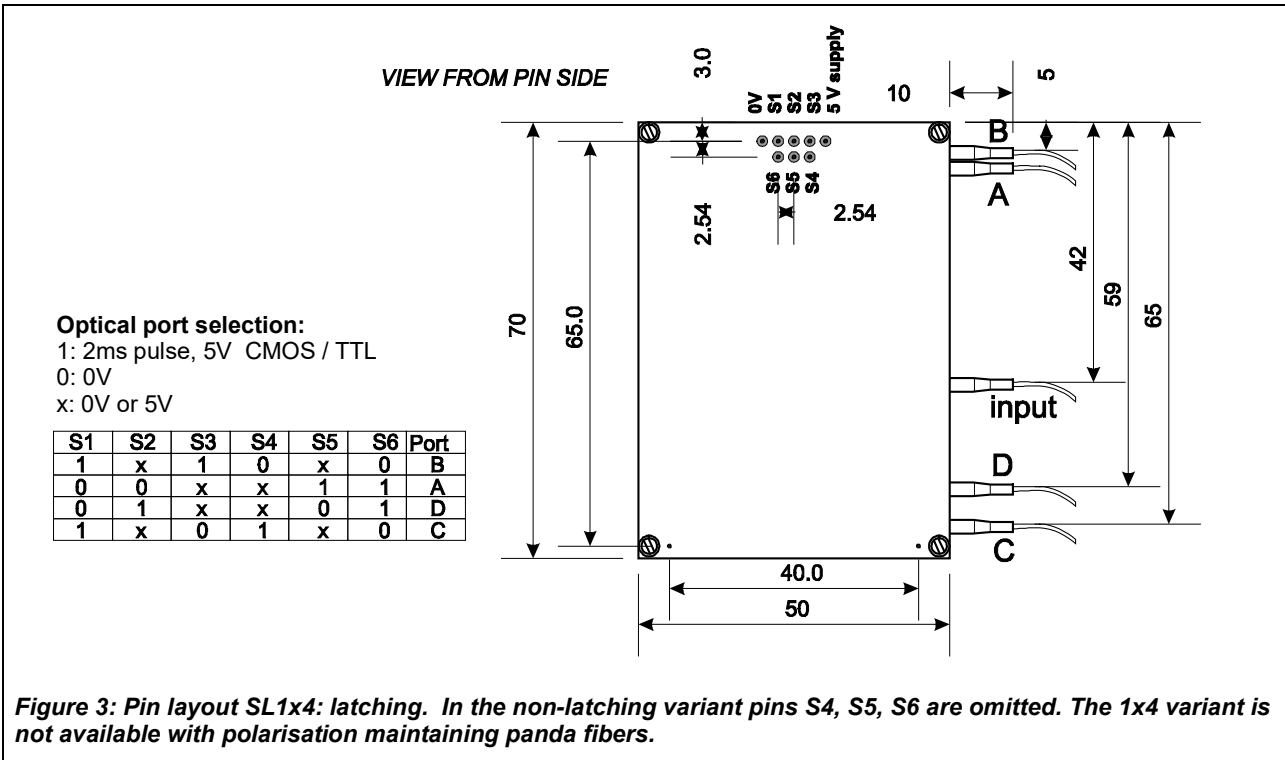
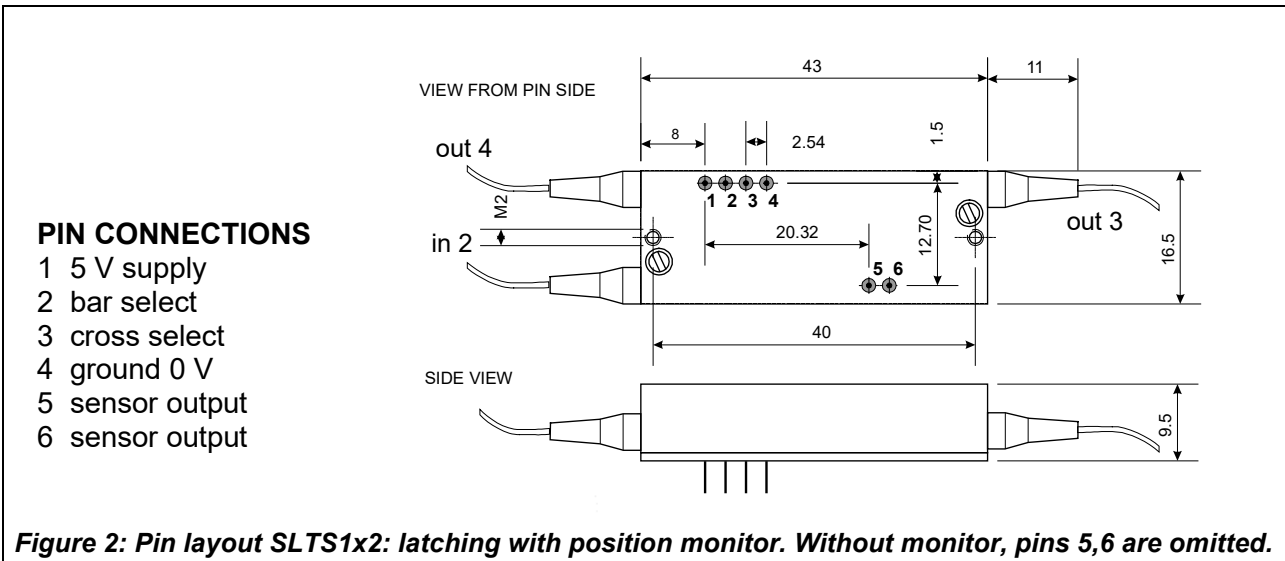
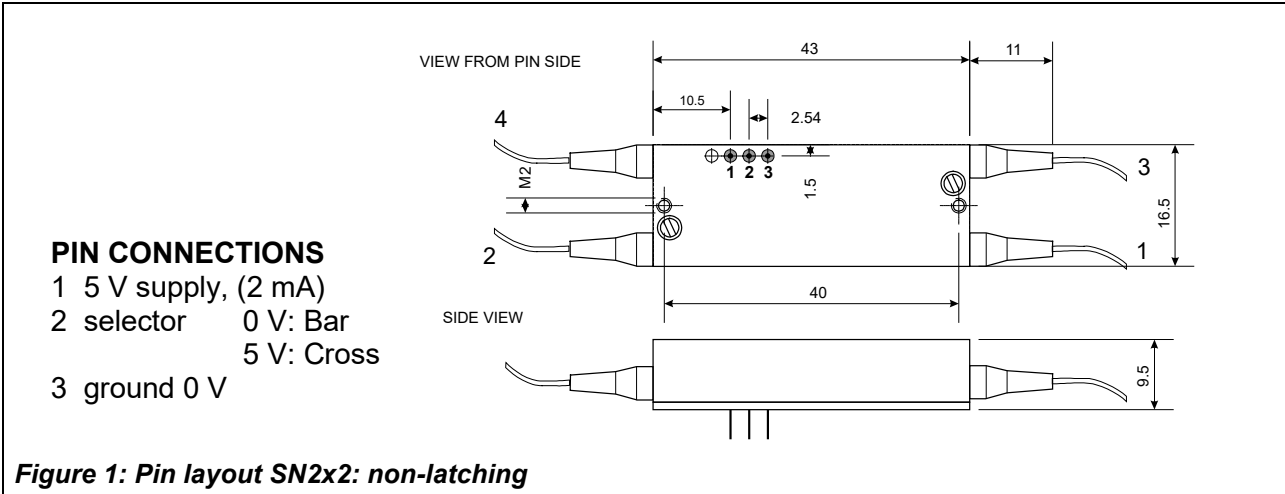



## **FIBER OPTIC MEMS SWITCH**

for Specialty Fibers  
or Polarisation-Maintaining  
Fibers



### **OVERVIEW**

The **sercalo** *sn* series are opto-mechanical switches for the most demanding applications in fiber optic sensor systems and instrumentation. The switch is available in 1x1, 1x2, 2x2 and 1x4 variants. The switch mechanism is available in either latching or non latching variants and has a very fast response time below 1 ms and below 1.5 dB insertion loss. The single mode switch is available for a number of specialty fibers covering design wavelengths such as 488 nm, 515 nm, 633 nm, 680 nm, 780 nm, 830 nm, 980 nm and 1064 nm. The 1x2 and 2x2 variants can also be made with polarisation maintaining PANDA fibers.

The miniature package withstands rugged environments and is well suited for direct mounting on printed circuit boards. The switch is qualified according to Telcordia GR 1221.

### **FEATURES**

- reliable
- specialty fibers
- 1.5 dB insertion loss
- 1 ms response time
- low PDL
- 60 dB crosstalk
- miniature size
- 2x2, 2x1, 1x1 variants

### **APPLICATIONS**

- Instrumentation
- Source selection

Distributor



info@amstechnologies.com  
www.amstechnologies-webshop.com



#### **CONTACT:**

Sercalo microtechnology ltd  
Landstrasse 151, 9494 Schaan  
Principality of Liechtenstein  
Tel. +423 237 57 97 Fax. +423 237 57 48  
www.sercalo.com e-mail: [info@sercalo.com](mailto:info@sercalo.com)

## DESCRIPTION

The **sercalo** switches are composed of an optical subsystem and an electrical driver interface. The optical switching function is realised by a silicon MEMS chip. In the latching *SL* variants, a bistable suspension mechanism keeps the last selected state in power off. In the non-latching *SN* variants, the switch returns into the bar state when electrical power is removed.

To operate the switch 5V and 0V are applied on the supply pins, which are used by the internal DC-DC converter to supply a high voltage for the actuator control. CMOS or TTL logic levels on the control pins switch the high voltage on the electrostatic actuator. To set the switch state in the *latching variant*, pin 2 respectively pin 3 are set to logic high (5V) for 10 ms and the corresponding switch state is selected. At rest pins 3 and 4 should be pulled to 0 V and must not be floating.

In the *non-latching variant* only pin 2 is used to set the state of the switch. To set the cross-state pin 3 must be at logic high. When pin 3 goes to logic low, or at power off, the switch returns into the bar state.

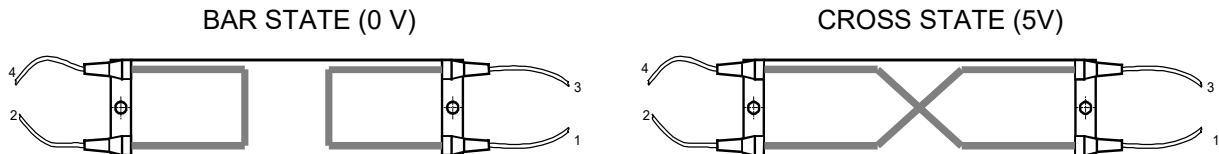

## TECHNICAL SPECIFICATIONS

	Unit	Min	Typ	Max
<b>Switch</b>				
Wavelength Range	nm	Cut off	~Cut Off +200 nm	
Insertion Loss <sup>1</sup>	dB		0.7	1.5
Crosstalk	dB		75	60
Backreflection	dB		55	50
Polarisation Dependent Loss	dB		0.02	0.05
Polarisation Extinction Ratio <sup>2</sup>	dB	18	24	
Repeatability <sup>3</sup>	dB			0.001
Switching Time	ms		0.5	1
Durability	cycles		1 billion	
<b>Package</b>				
Voltage	V	4	5	5.25
Power Consumption	mW		5	10
Operation Temperature	°C	0		70
Storage Temperature	°C	-40		85
Size (L x W x H)	mm		40x16.5x9.5	

<sup>1</sup> for 1x2, 2x2 switch, fibers=5,6,7 excluding connector loss. Fibers 2,3 and 4 = 2 dB max. For 1x4 switch ILmax < 3.0 dB

<sup>2</sup> with Panda fibers for 7 and 9 only.

<sup>3</sup> value for constant temperature and polarisation

## ORDERING INFORMATION

Switch type	State monitor	Variants	Cut Off (design) Wavelength	Polarisation Maintenance
L = latching N = non-latching	- = no monitor TS= position monitor (latching only)	2X2 1X4 (not for PM) 1X2 (no port 4) 1X1 (no ports 4,2)	3 = <450 nm (for 488 and 514 nm) 4 = <600 nm (for 633 and 680 nm) 5 = <750 nm (for 780 nm) 6 = <800 nm (for 830 nm) 7 = <970 nm (for 980, 1064, 1550 nm) 9 = <1250 nm (for 1310 and 1550 nm)	PM=panda fiber, only for 970, 1310, 1550nm - = single mode fiber

**Fibre sleeve type**  
N = loose tube 0.9mm  
B = bare fibre 0.25mm

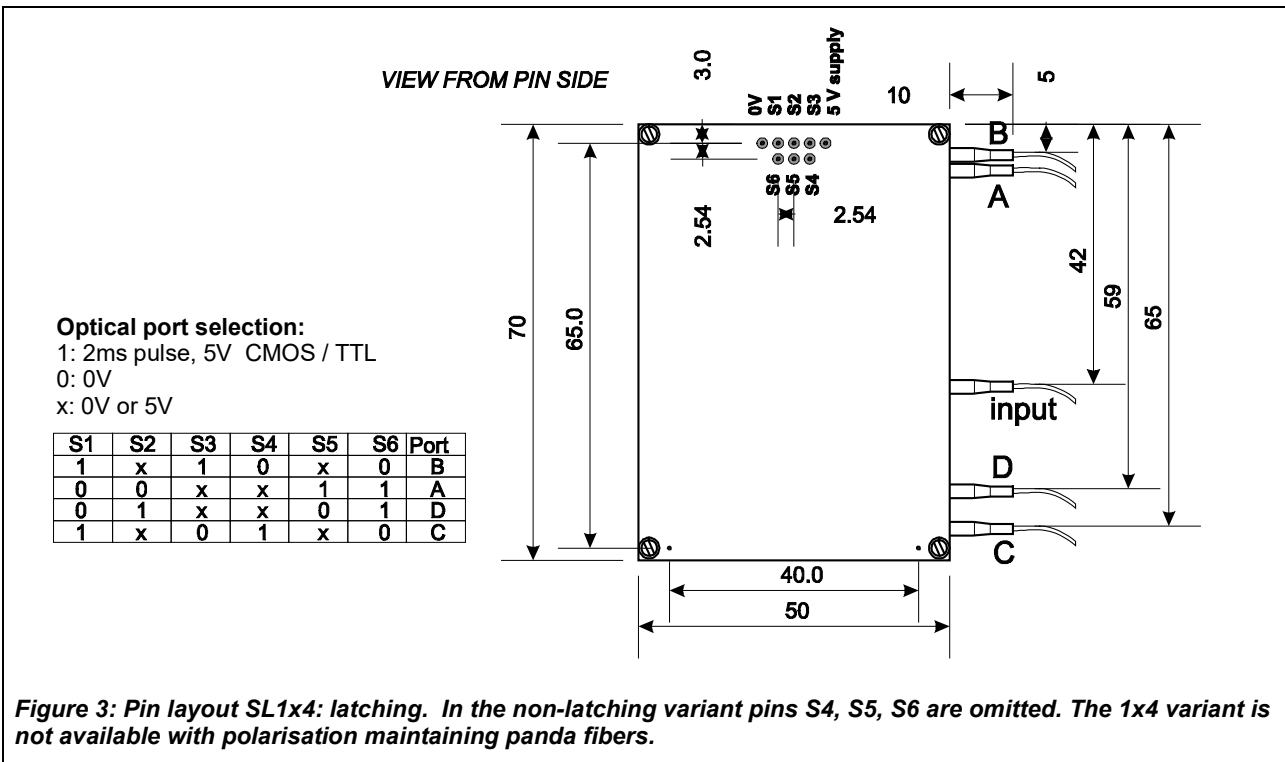
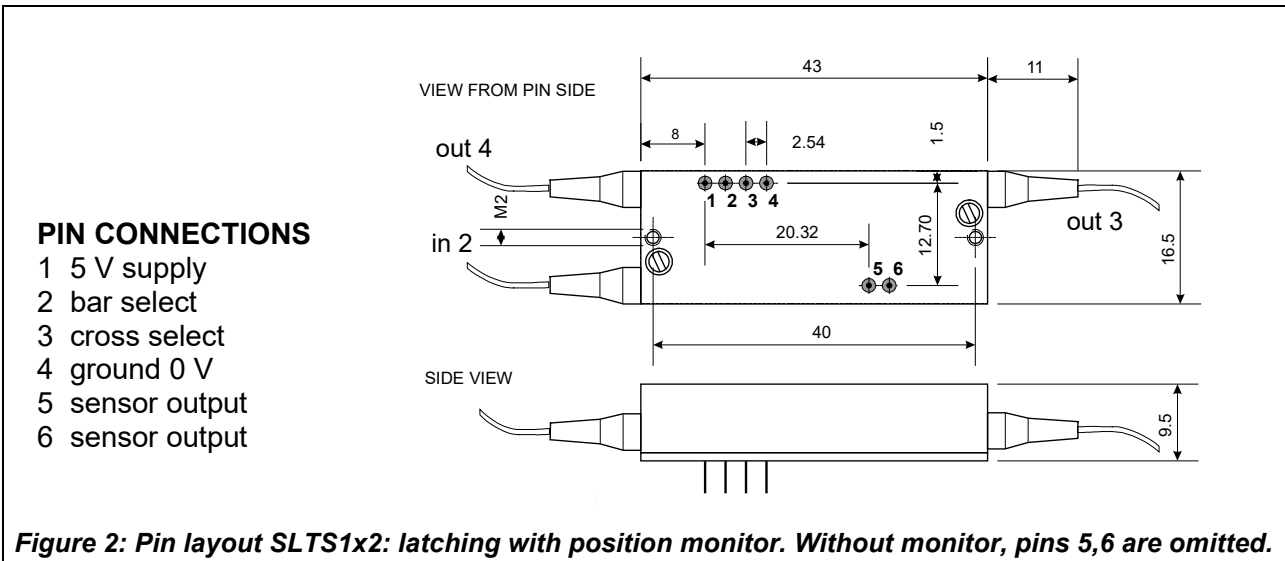
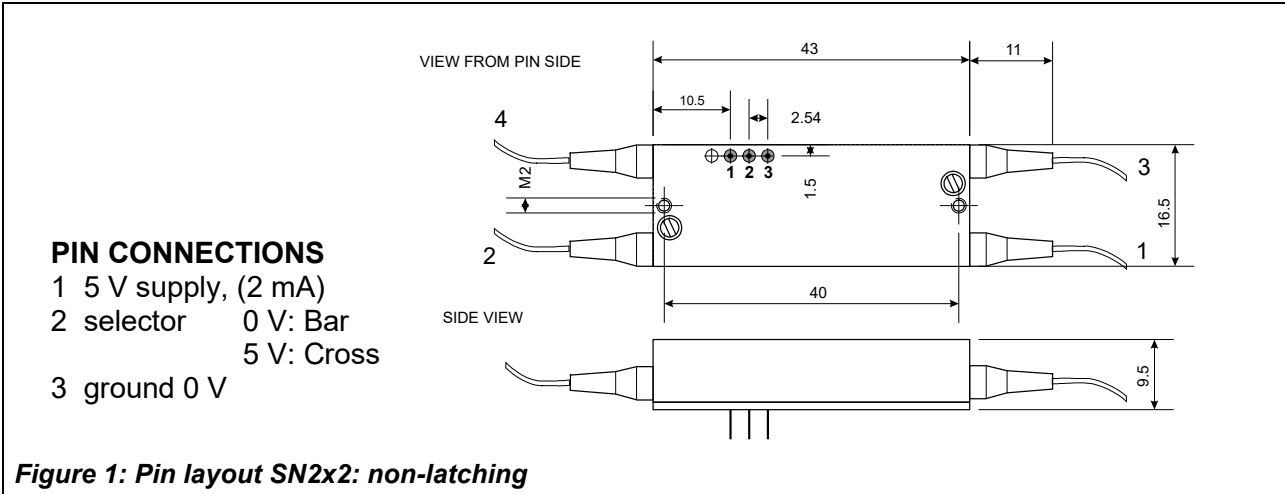

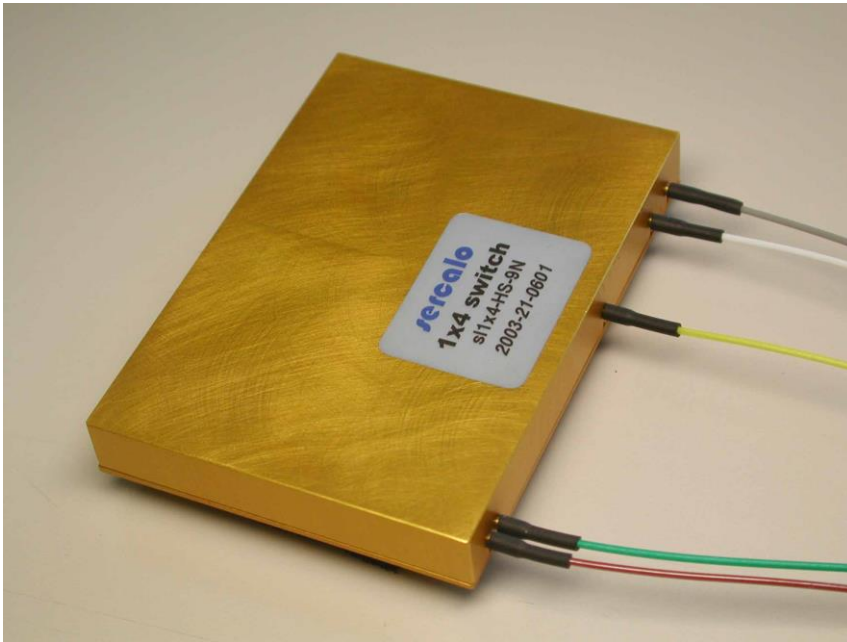

## **FAST FIBER OPTIC 1x4 SWITCH**



### **OVERVIEW**

The **sercalo** 1x4 switch is a very fast opto-mechanical switch working over both telecom wavelength windows from 1240 nm to 1600 nm. The highly reliable switching mechanism is based on micromechanical mirrors and features below 1 ms switching time and below 1.2 dB insertion loss.

The miniature package withstands rugged environments and is well suited for direct mounting on printed circuit boards. The switch is built by cascading 1x2 switches which are qualified according to Telcordia GR1221.

### **APPLICATIONS**

- Source Selection
- Protection Switching
- Monitoring
- Wavelength provisioning

### **FEATURES**

- reliable
- 0.7 dB insertion loss
- 1 ms response time
- 60 dB crosstalk
- non-latching

### **ORDERING INFORMATION** SN1x4-9N

#### **CONTACT:**

Sercalo Microtechnology Ltd.  
Landstrasse 151, FL-9494 Schaan  
Principality of Liechtenstein  
Tel. +423 237 57 97 Fax. +423 237 57 48  
www.sercalo.com e-mail: [info@sercalo.com](mailto:info@sercalo.com)



[info@amstechnologies.com](mailto:info@amstechnologies.com)  
[www.amstechnologies-webshop.com](http://www.amstechnologies-webshop.com)



TECHNICAL SPECIFICATIONS	Unit	Min	Typ	Max
<b>Switch</b>				
Wavelength Range	nm	1240		1640
Insertion Loss <sup>1</sup>	dB		0.7	1.2
Wavelength d. Loss per band	dB			0.2
Temperature d. Loss	dB			0.3
Crosstalk	dB		75	60
Backreflection	dB		55	50
Polarisation Dependent Loss	dB		0.05	0.10
Repeatability <sup>2</sup>	dB			0.001
Max. input power / port	dBm			20
Switching Time	ms		0.5	1
Fiber Pigtail	µm		9/125/900	
Durability	cycles		no wear out	
<b>Integrated Driver</b>				
Supply Voltage V	V	4.75	5	5.25
Current Consumption /	mA		2	10
Logic Level Low	V			0.8
Logic Level High	V	0.8		
ESD protection of pins			500 V Human body model	
Maximum Voltage ratings	V	-0.2		+6.0
Maximum Current ratings	mA	-10		+10
<b>Package</b>				
Operation Temperature	°C	0		70
Storage Relative Humidity	%	0		85
Size (L x W x H)	mm		70 x 50 x 9.5	

<sup>1</sup> value excluding connectors. Add 0.25 dB to account for temperature and wavelength dependent loss.  
<sup>2</sup> value for constant temperature and polarisation.

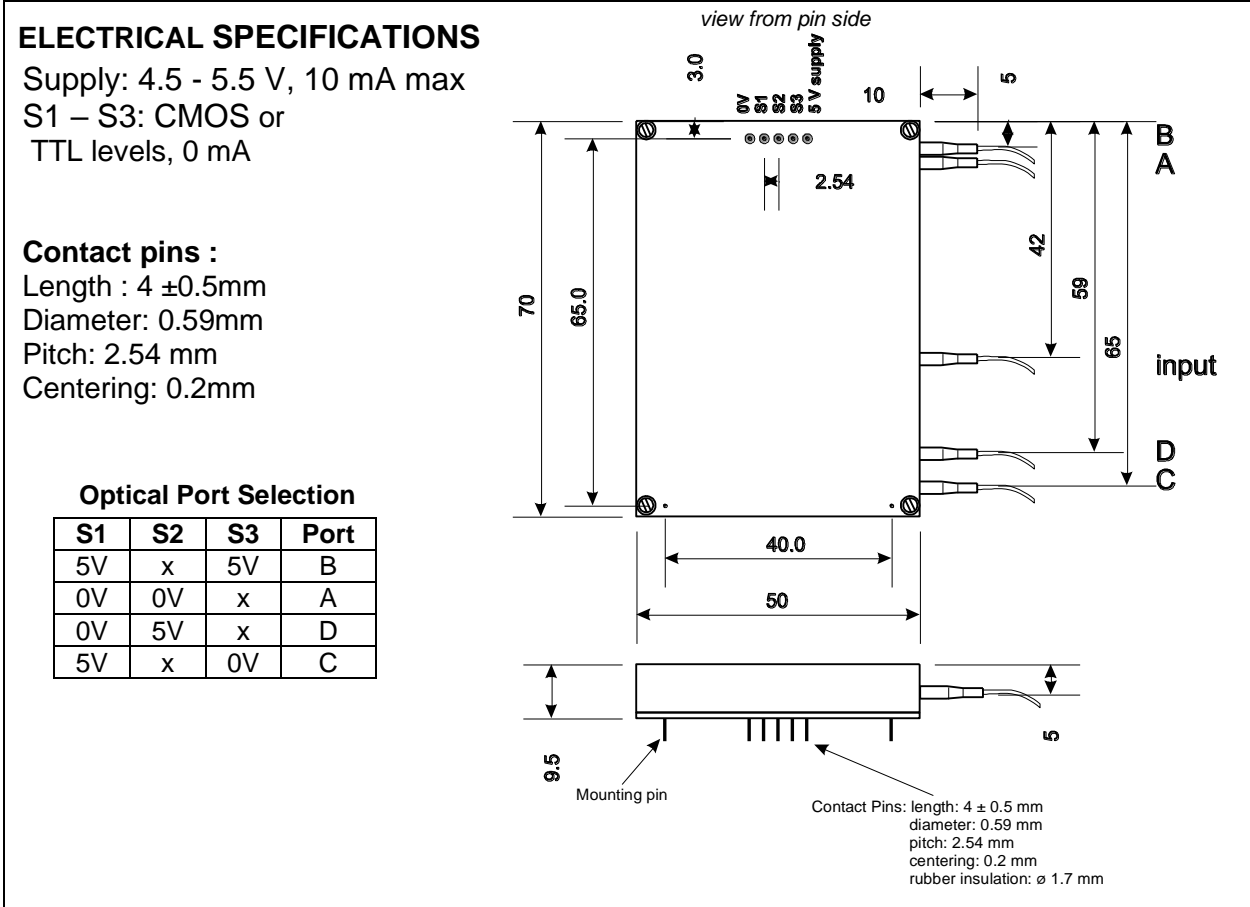



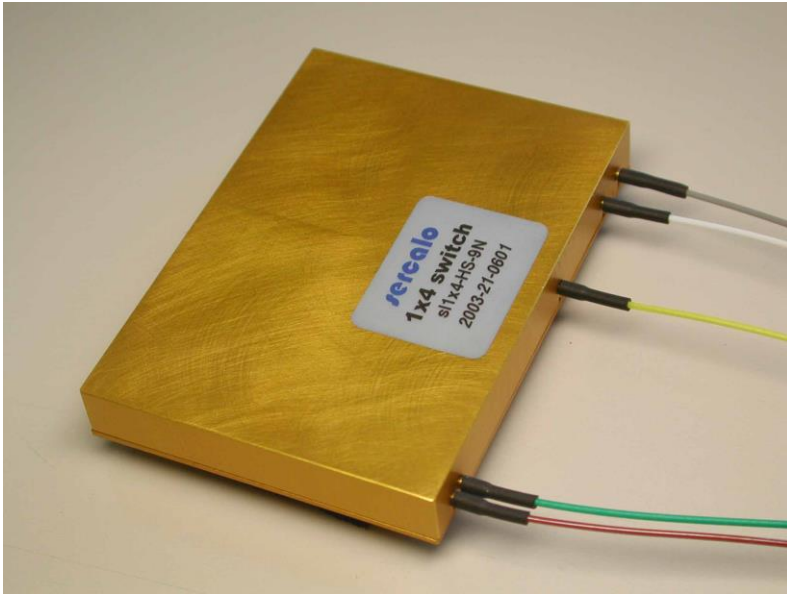

## FIBER OPTIC MEMS SWITCH

for specialty fibers  
or Polarisation-Maintaining  
Fibers



### OVERVIEW

The **sercalo** *sn* series are opto-mechanical switches for the most demanding applications in fiber optic sensor systems and instrumentation. The switch is available in 1x1, 1x2, 2x2 and 1x4 variants. The switch mechanism is available in either latching or non latching variants and has a very fast response time below 1 ms and below 1.5 dB insertion loss. The single mode switch is available for a number of specialty fibers covering design wavelengths such as 488 nm, 515 nm, 633 nm, 680 nm, 780 nm, 830 nm, 980 nm and 1064 nm. It can also be made with polarisation maintaining PANDA fibers.

The miniature package withstands rugged environments and is well suited for direct mounting on printed circuit boards. The switch is qualified according to Telcordia GR 1221.

### FEATURES

- reliable
- specialty fibers
- 1.5 dB insertion loss
- 1 ms response time
- low PDL
- 60 dB crosstalk
- miniature size
- 2x2, 2x1, 1x1 variants

### APPLICATIONS

- Instrumentation
- Source selection

#### CONTACT:

Sercalo microtechnology ltd  
Landstrasse 151, FL-9494 Schaan  
Principality of Liechtenstein  
Tel. +423 237 57 97 Fax. +423 237 57 48  
www.sercalo.com e-mail: [info@sercalo.com](mailto:info@sercalo.com)

## DESCRIPTION

The **sercalo** switches are composed of an optical subsystem and an electrical driver interface. The optical switching function is realised by a silicon MEMS chip, on which a mirror can be moved in and out of the optical path by electrostatic actuation. In the latching *SL* variants a bistable suspension mechanism keeps the last selected state in power off. In the non-latching *SN* variants the switch returns into the bar state when electrical power is removed.

The absence of fatigue and wear-out allows to achieve a constant switching quality even after billions of actuation cycles. The switch features fast switching below 1 ms and high crosstalk attenuation above 60 dB. Repeatability is better than 0.001 dB. The switch is powered by a 5 V supply voltage. A 5 V TTL or CMOS drive signal is used to control the switching state.

TECHNICAL SPECIFICATIONS				
	Unit	Min	Typ	Max
<b>Switch</b>				
Wavelength Range	nm	Cut off	~Cut Off +200 nm	
Insertion Loss <sup>1</sup>	dB		2.0	3.0
Crosstalk	dB		75	60
Backreflection	dB		55	50
Polarisation Dependent Loss	dB		0.05	0.1
Polarisation Extinction Ratio <sup>2</sup>	dB	20	25	
Repeatability <sup>3</sup>	dB			0.001
Switching Time	ms		0.5	1
Durability	cycles		1 billion	
<b>Package</b>				
Voltage	V	4	5	5.25
Power Consumption	mW		5	10
Operation Temperature	°C	0		70
Storage Temperature	°C	-40		85
Size (L x W x H)	mm		70x70x9.5	
<sup>1</sup> for 1x4 excluding connector loss. <sup>2</sup> with Panda fibers for 1550 nm.				
<sup>3</sup> value for constant temperature and polarisation				

ORDERING INFORMATION				
<div style="display: flex; justify-content: space-around; align-items: center;"> <div style="border: 1px solid black; padding: 2px 5px;">S</div> <div style="border: 1px solid black; padding: 2px 5px;">N</div> <div style="border: 1px solid black; padding: 2px 5px;">-</div> <div style="border: 1px solid black; padding: 2px 5px;">1x4</div> <div style="border: 1px solid black; padding: 2px 5px;">-</div> <div style="border: 1px solid black; padding: 2px 5px;">3</div> <div style="border: 1px solid black; padding: 2px 5px;">-</div> <div style="border: 1px solid black; padding: 2px 5px;">N</div> </div>				
<b>Switch type</b> L = latching N = non- latching	<b>State monitor</b> - = no monitor TS= position monitor (latching only)	<b>Variants</b> 1X4	<b>Cut Off (design) Wavelength</b> 3 = <450 nm (for 488 and 514 nm) 4 = <600 nm (for 633 and 680 nm) 5 = <750 nm (for 780 nm) 6 = <800 nm (for 830 nm) 7 = <970 nm (for 980, 1064 and 1550 nm) 9 = <1250 nm (for 1310 and 1550 nm)	<b>Fibre sleeve type</b> N = loose tube 0.9mm B = bare fibre 0.25mm  <b>Polarisation Maintenance</b> PM=panda fiber - = single mode fiber

### PIN CONNECTIONS

- 1 5 V supply, (2 mA)
- 2 selector 0 V: Bar  
5 V: Cross
- 3 ground 0 V

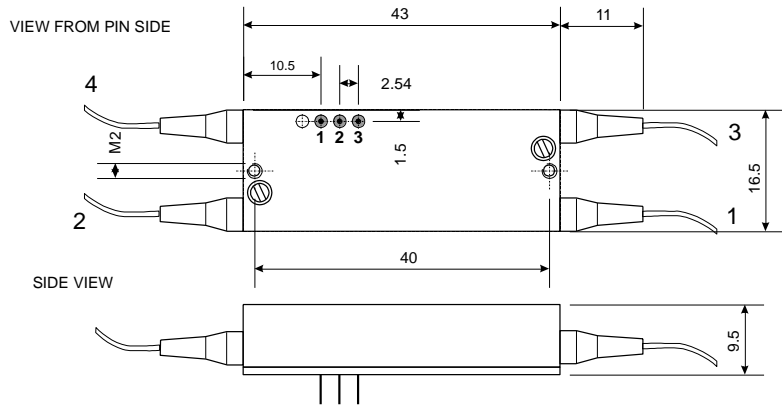

Figure 1: Pin layout SN2x2: non-latching

### PIN CONNECTIONS

- 1 5 V supply
- 2 bar select
- 3 cross select
- 4 ground 0 V
- 5 sensor output
- 6 sensor output

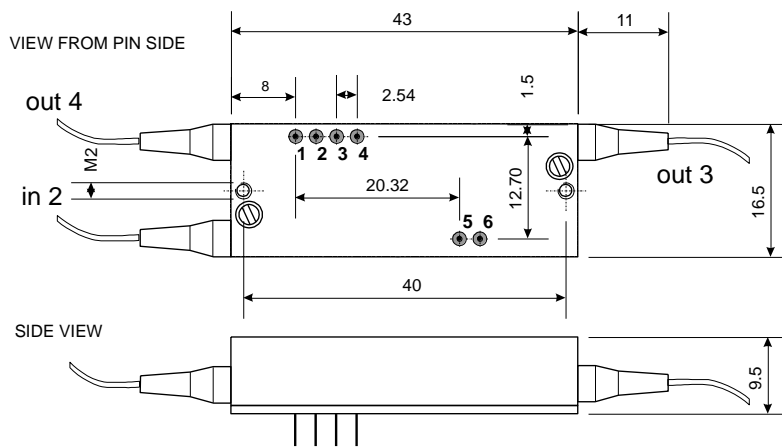

Figure 2: Pin layout SLTS1x2: latching

### Optical port selection:

- 1: 2ms pulse, 5V CMOS / TTL
- 0: 0V
- x: 0V or 5V

S1	S2	S3	S4	S5	S6	Port
1	x	1	0	x	0	B
0	0	x	x	1	1	A
0	1	x	x	0	1	D
1	x	0	1	x	0	C

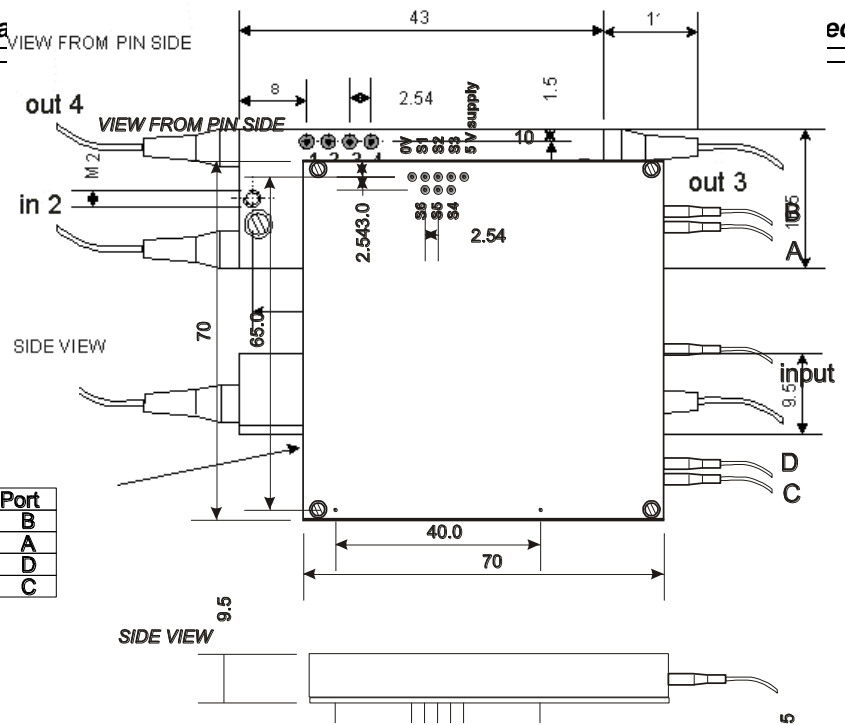

Figure 3: Pin layout SL1x4: latching. In the non-latching variant pins S4, S5, S6 are omitted.



## FIBER OPTIC MEMS SWITCH

*for specialty fibers or  
Polarisation-Maintaining fibers*



### OVERVIEW

The **sercalo** *sn* series are opto-mechanical switches for the most demanding applications in fiber optic sensor systems and instrumentation. The switch is available in 1x1, 1x2, 2x2 and 1x4 variants. The switch mechanism is available in either latching or non latching variants and has a very fast response time below 1 ms and below 1.5 dB insertion loss. The single mode switch is available for a number of specialty fibers covering design wavelengths such as 488 nm, 515 nm, 633 nm, 680 nm, 780 nm, 830 nm, 980 nm and 1064 nm. The 1x2 and 2x2 variants can also be made with polarisation maintaining PANDA fibers.

The miniature package withstands rugged environments and is well suited for direct mounting on printed circuit boards. The switch is qualified according to Telcordia GR 1221.

### FEATURES

- reliable
- specialty fibers
- 1.5 dB insertion loss
- 1 ms response time
- low PDL
- 60 dB crosstalk
- miniature size
- 2x2, 2x1, 1x1 variants

### APPLICATIONS

- Instrumentation
- Source selection

#### Contact:

Sercalo Microtechnology Ltd.  
Landstrasse 151, 9494 Schaan  
Fürstentum Liechtenstein  
Tel. +423 237 57 97 Fax. +423 237 57 48  
www.sercalo.com e-mail: [info@sercalo.com](mailto:info@sercalo.com)

## DESCRIPTION

The **sercalo** switches are composed of an optical subsystem and an electrical driver interface. The optical switching function is realised by a silicon MEMS chip. In the latching *SL* variants, a bistable suspension mechanism keeps the last selected state in power off. In the non-latching *SN* variants, the switch returns into the bar state when electrical power is removed.

To operate the switch 5V and 0V are applied on the supply pins, which are used by the internal DC-DC converter to supply a high voltage for the actuator control. CMOS or TTL logic levels on the control pins switch the high voltage on the electrostatic actuator. To set the switch state in the *latching variant*, pin 2 respectively pin 3 are set to logic high (5V) for 10 ms and the corresponding switch state is selected. At rest pins 3 and 4 should be pulled to 0 V and must not be floating.

In the *non-latching variant* only pin 2 is used to set the state of the switch. To set the cross-state pin 3 must be at logic high. When pin 3 goes to logic low, or at power off, the switch returns into the bar state.

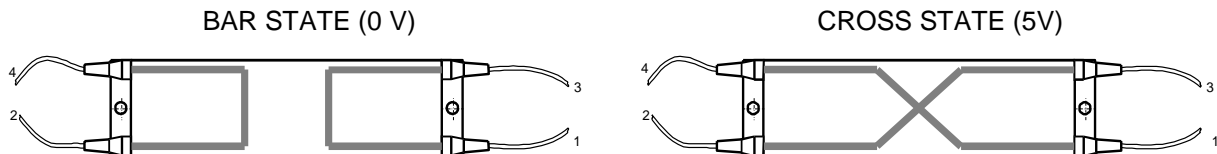

## TECHNICAL SPECIFICATIONS

	Unit	Min	Typ	Max
<b>Switch</b>				
Wavelength Range	nm	Cut off	~Cut Off +200 nm	
Insertion Loss <sup>1</sup>	dB		0.7	1.5
Crosstalk	dB		75	60
Backreflection	dB		55	50
Polarisation Dependent Loss	dB		0.02	0.05
Polarisation Extinction Ratio <sup>2</sup>	dB	18	24	
Repeatability <sup>3</sup>	dB			0.001
Switching Time	ms		0.5	1
Durability	cycles		1 billion	
<b>Package</b>				
Voltage	V	4	5	5.25
Power Consumption	mW		5	10
Operation Temperature	°C	0		70
Storage Temperature	°C	-40		85
Size (L x W x H)	mm		40x16.5x9.5	

<sup>1</sup> for 1x2, 2x2 switch, fibers=5,6,7 excluding connector loss. Fibers 2,3 and 4 = 2 dB max. For 1x4 switch ILmax < 3.0 dB

<sup>2</sup> with Panda fibers for 7 and 9 only..

<sup>3</sup> value for constant temperature and polarisation

## ORDERING INFORMATION

Switch type	State monitor	Variants	Cut Off (design) Wavelength	Polarisation Maintenance
L = latching N = non- latching	- = no monitor TS= position monitor (latching only)	2X2 1X4 (not for PM) 1X2 (no port 4) 1X1 (no ports 4,2)	3 = <450 nm (for 488 and 514 nm) 4 = <600 nm (for 633 and 680 nm) 5 = <750 nm (for 780 nm) 6 = <800 nm (for 830 nm) 7 = <970 nm (for 980, 1064, 1550 nm) 9 = <1250 nm (for 1310 and 1550 nm)	PM=panda fiber, only for 970, 1310, 1550nm - = single mode fiber

**Fibre sleeve type**  
N = loose tube 0.9mm  
B = bare fibre 0.25mm

