



## PYQ 1398 • PYQ 1348

### Quad-Element Detectors, low-cost

This series of Four-Element “Quad” Detectors provides all four elements connected to one common output. This configuration enables specific applications in ceiling-mount locations when applied with suitable lens- or mirror-optic designs. Two different window options are available to accommodate different fields-of-view. PYQ 13## Quad-Element Detectors further provide added 1K Ohm Resistor in the drain connection and a built-in capacitor to ground. Both contribute to reduced sensitivity to electromagnetic disturbances.

The standard geometric element layout offers equal distance and spacing with cross polarity. Customized options of other polarities and geometries are available upon request.

#### Features and Benefits

- TO-5 metal housing
- Different window sizes
- EMI protection
- Designed for ceiling mount motion detection

**Distributor**

**amSTECHNOLOGIES**  
where technologies meet solutions

nordics@amstechnologies.com  
azpect.amstechnologies.com

**Contact us**

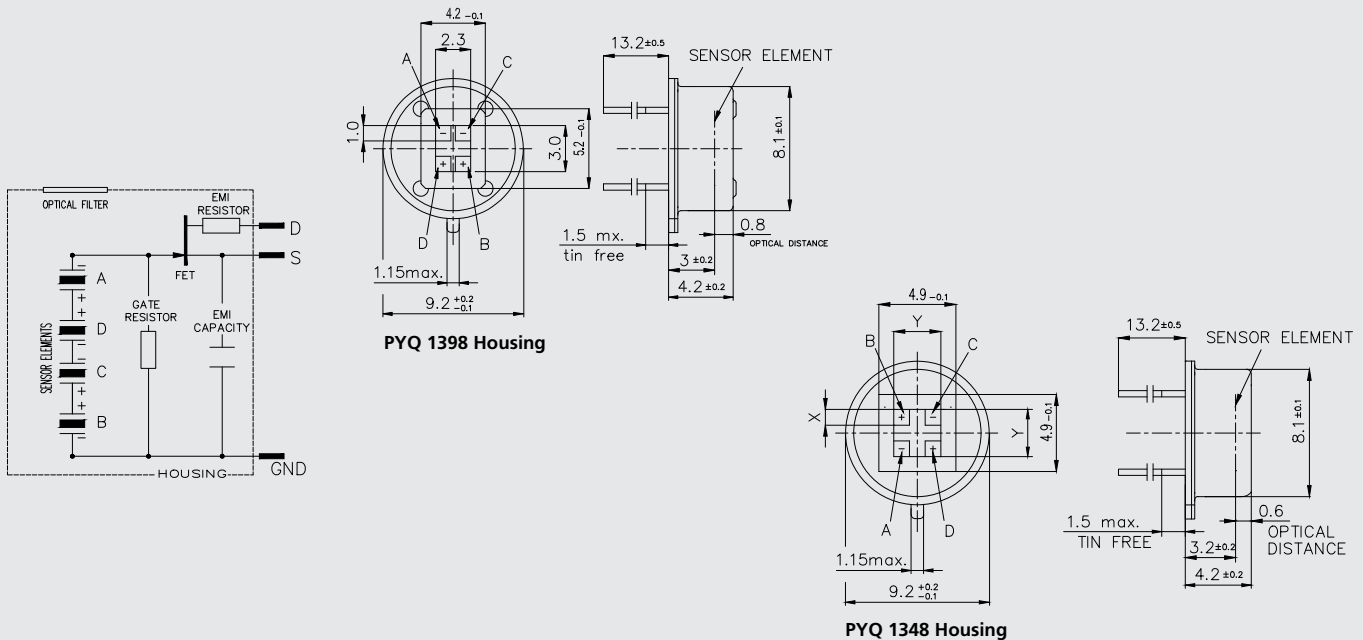

#### PYQ 1398 - PYQ1348

Parameter	Symbol	PYQ 1388	PYQ 1348	Unit	Remarks
Responsivity, min.	$R_{min}$	5.4	5.4	kV/W	$f = 1 \text{ Hz}$
Responsivity, typ.	R	6.5	6.5	kV/W	$f = 1 \text{ Hz}$
Match, max.	$M_{max}$	15	15	%	
Noise, max.	$N_{max}$	100	100	$\mu\text{V}_{pp}$	0.4...10Hz/20°C
Noise, typ.	N	40	40	$\mu\text{V}_{pp}$	0.4...10Hz/20°C
Source Voltage		0.2 ... 1.55	0.2 ... 1.55	V	47 K $\Omega$ , 20°C, $V_{DD}=10\text{V}$
Operating Voltage		2.0...10	2.0...10	V	47 K $\Omega$ , 20°C
Field of View, horizontal	FoV	103°	124°		unobstructed
Field of View, vertical		100°	124°		unobstructed
Filter Size	X/Y	5.2 / 4.2	4.9 / 4.9	mm	



**PYQ 2498 • PYQ 5448**

**Quad-Element Pyro, Dual-Channel Output**

This Detector family is distinguished by two pair of sensing elements, each with its individual output. As to the spacing of the sensing elements, various designs are available. The TO-5 housing is provided with suitable window size to accommodate the field-of-view of the element configuration.

**Features and Benefits**

- TO-5 metal housing
- Dual Channel Output
- Square / rectangular window options
- Customized Element configuration options
- Suitable for wall mount and ceiling mount applications

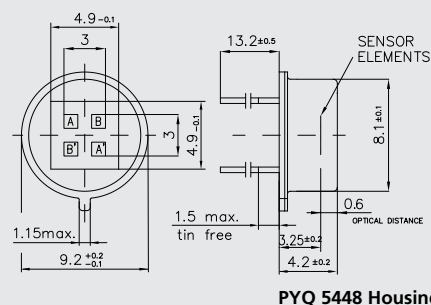
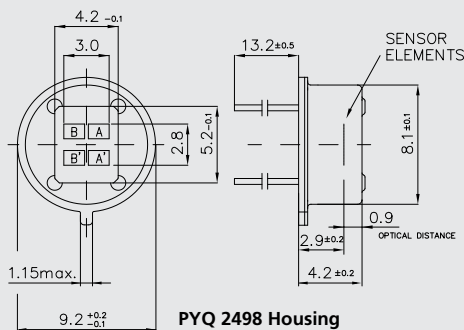
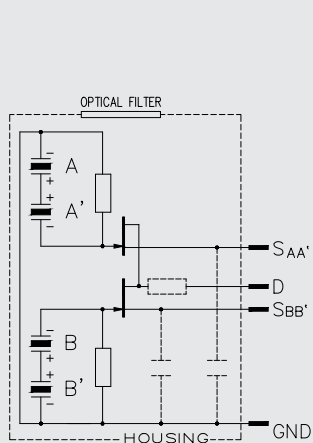

**PYQ 2498 - PYQ 5448**

Parameter	Symbol	PYQ 2498	PYQ 5448	Unit	Remarks
Responsivity, min.	$R_{min}$	3.5	4.4	kV/W	$f = 1 \text{ Hz}$
Responsivity, typ.	$R$	5.5	8	kV/W	$f = 1 \text{ Hz}$
Match, max.	$M_{max}$	15	15	%	
Noise, max.	$N_{max}$	75	75	$\mu\text{V}_{pp}$	0.4...10Hz/20°C
Noise, typ.	$N$	30	30	$\mu\text{V}_{pp}$	0.4...10Hz/20°C
Source Voltage		0.2 ... 1.55	0.2 ... 1.55	V	47 K $\Omega$ , 20°C, $V_{DD}=10\text{V}$
Operating Voltage		2.0...10	2.0...10	V	47 K $\Omega$ , 20°C
Field of View, horizontal	FoV	110°	95		unobstructed
Field of View, vertical		87°	95		unobstructed
Filter Size	X/Y	5.2 / 4.2	4.9 / 4.9	mm	

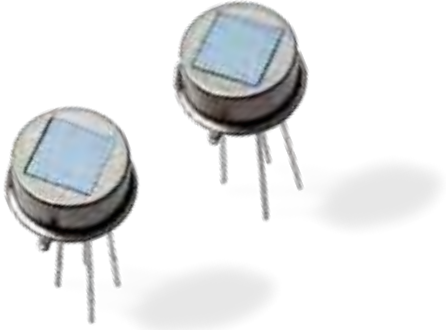

**PYQ 1548**

**Quad-Element Low Power DigiPyro®**

This Quad-Element DigiPyro configures all four elements combined to one output with exceptional energy-efficiency. The user selects and sets individual functions. A single-wire connection with separate input pin allows setting of sensitivity, bandpass selection, pulse count and wake up. This provides full functionality of a complete PIR sensing device when all following circuitry is in sleep mode.

**PYQ 1748**

**Quad-Element DigiPyro®**

This DigiPyro provides economical Quad configuration with all four elements combined to one common output. This enables ceiling-mount applications when applied with suitable lens optics. TO-5 housing is provided with rectangular window to accommodate wider field-of-view. Standard geometrical element layout offers equal distance and spacing with cross polarity.

**Features and Benefits**

- TO-5 metal housing
- Equal element spacing
- Digital output via direct link
- Designed for ceiling-mount applications

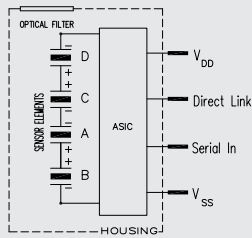

**PYQ 1548 Electrical**

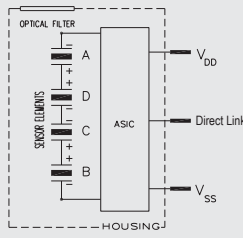

**PYQ 1748 Electrical**

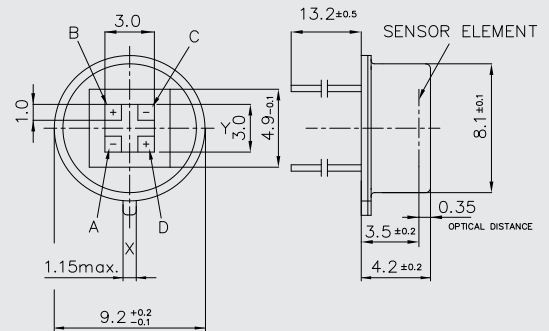

**PYQ 1548 Housing and PYQ 1748 Housing**

**PYQ 1548 - PYQ 1748**

Parameter	Symbol	PYQ 1748	PYQ 1548	Unit	Remarks
Responsivity, min.	R <sub>min</sub>	5.4	5.4	kV/W	f = 1 Hz
Responsivity, typ.	R	6.5	6.5	kV/W	f = 1 Hz
Match, max.	M <sub>max</sub>	10	10	%	
Noise, max.	N <sub>max</sub>	140	140	μV <sub>pp</sub>	0.4...10Hz/20°C
Noise, typ.	N	30	30	μV <sub>pp</sub>	0.4...10Hz/20°C
Operating Voltage		1.8...3.6	1.8...3.6	V	
Supply Current	I <sub>DDmax</sub>	7	7	μA	V <sub>DD</sub> = 3.3V, no load
Field of View, horizontal	FoV	148	124	°	unobstructed, typ.
Field of View, vertical		148	124	°	unobstructed, typ.
Filter Size	X/Y	4.9 / 4.9	4.9 / 4.9	mm	
<b>ADC Data</b>					
Resolution		14	15	bit	typ.
Sensitivity		6.5	6.5	μV/count	typ.
Offset		8192	8000	bitcount	typ.



**PYQ 2898 • PYQ 5848**

**Quad-Element DigiPyro®**

This Detector family is distinguished by two pairs of sensing elements with digitized signals for each pair. Together with the signal of an internal reference diode, the output via digital link forms a 3x14 bit stream. As to the spacing of the sensing elements, various designs are available. The TO-5 housing is provided with suitable window size to accommodate the field-of-view of the element configuration.

**Features and Benefits**

- TO-5 metal housing
- Dual-channel output
- Square / rectangular window
- Different element configuration options
- Suitable for wall and ceiling mount applications

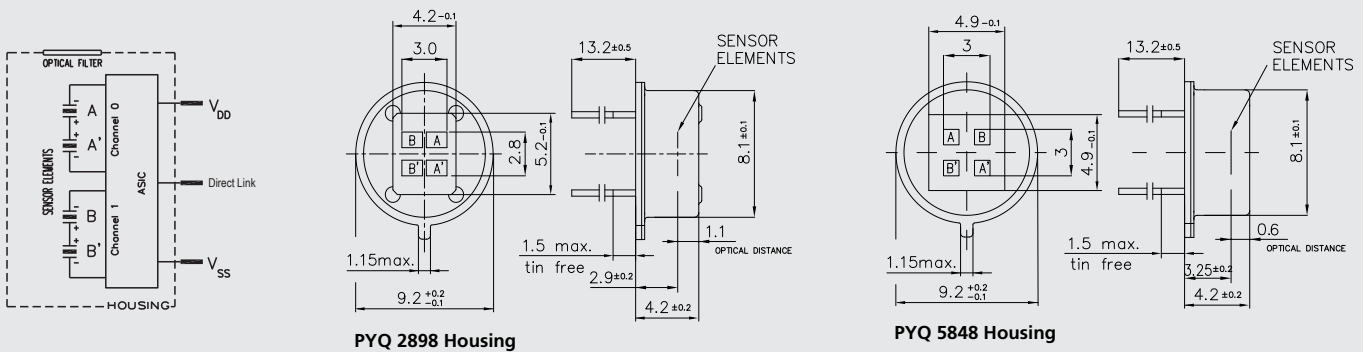

PYQ 2898 - PYQ 5848						
Parameter	Symbol	PYQ 2898	PYQ 5848	Unit	Remarks	
Responsivity, min.	R <sub>min</sub>	3.5	6.0	kV/W	f = 1 Hz	
Responsivity, typ.	R	4.5	8.0	kV/W	f = 1 Hz	
Match, max.	M <sub>max</sub>	10	10	%		
Noise, max.	N <sub>max</sub>	80	100	µV <sub>pp</sub>	0.4...10Hz/20°C	
Noise, typ.	N	30	40	µV <sub>pp</sub>	0.4...10Hz/20°C	
Operating Voltage		2.7...3.6	2.7...3.6	V		
Supply Current	I <sub>DDmax</sub>	15	15	µA	V <sub>DD</sub> = 3.3V, no load	
Field of View, horizontal	FoV	100	124	°	unobstructed, typ.	
Field of View, vertical		60	124	°	unobstructed, typ.	
Filter Size	X/Y	5.2 / 4.2	4.9 / 4.9	mm		
<b>ADC Data</b>						
Resolution		14	14	bit	typ.	
Sensitivity		6.5	6.5	µV/count	typ.	
Offset		8192	8192	bitcount	typ.	

## Handling

Infrared Sensors are Optical devices and require careful handling in production. As to mechanical recommendations:

- Avoid dropping the devices on the production flow.
- Avoid physical force to detector leads, do not bend leads unless necessary.
- Ensure leads are not damaged when manipulating them.

Electrostatic discharges may destroy the detectors. It is recommended to apply the standard precautions for ESD sensitive devices to prevent potential damage.

The detector windows are optical filters with multi-layer coatings.

- Avoid touching the detector window. To clean windows, use only ethyl alcohol with a cotton swab.
- Do not expose Detectors to chemical fluids such as Freon, Trichloroethylene and other aggressive detergents.

## Environmental Conditions

With the construction of metal can and spectral window inserted into the can by a special durable epoxy, the detectors are sealed and tested for long-term enclosure. The detector will pass He-leakage test with maximum leakage rate specification of  $5 \times 10^{-8}$  mbar ls-1. Detectors shall not increase noise or change responsivity when exposed to maximum of 95% relative humidity at 30°C.

- Avoid long-term storage at high humidity with high temperatures.

As IR detectors are optical sensors, avoid condensation effects on the detector. Operation below dew points may affect the performance.

## Reliability Standards

Excelitas' continuous reliability qualification and monitoring program ensures that all outgoing products meet quality and reliability standards. Tests are performed according to approved semiconductor device standards, such as IEC, MIL, and JEDEC (see table). For detailed information please contact Excelitas.

## Quality and Reliability Standards

Excelitas strives to meet applicable quality and reliability standards. We are certified ISO 9001:2015 and operate at established SPC and TQM. We are proud to operate under Environmental Management System according to ISO 14001:2015 and the Occupational Safety and Health Management System according to OHSAS 18001: 2007.

All devices employing PCB assemblies are manufactured according IPC-A-610 class 2 guidelines.

Excelitas Thermal Infrared Sensor product line is certified for ANSI/ESD S.20:2014.

In case of questions please feel free to contact us for the latest update on our current certificates and forms. Our continuous qualification and reliability program ensures that all products meet the specified performance criteria.

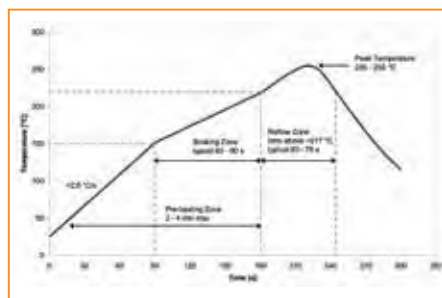

As to outgoing inspection, all devices have to pass 100% testing of major parameters and gross leak in acc. to MIL Std. 883 m 1014C1. Due to high-volume production individual data are not protocolled or stored, statistical data are kept for reference.

## Soldering of SMD Devices

The TPiD 1S and TPiS 1S series are lead-free components and fully comply with the RoHS regulations, especially with existing roadmaps of lead-free soldering. Reflow soldering is recommended. A typical lead free reflow profile is shown in figure 4. Specific reflow soldering parameters depend on the solder alloy used.

The device meets MSL1 at 245 °C according to JEDEC standard.

## Soldering Conditions

For the soldering of the detectors within PCBs, the typically applied and recommended process is wave soldering. During the automatic wave solder process we strongly advise to restrict preheating to avoid heat exposure through the detector window, if necessary apply a protection cap. When the detector is directly exposed to the radiation of such heaters the detector shall be protected from that heat. Manual soldering is also possible when maintaining similar temperature profiles.

Reflow soldering is not possible for TO housing versions of our detectors. For our range of SMD housing detectors please reference the recommended solder profile.

## From Analog to Digital

Excelitas Technologies was the first to introduce a digital interface to pyroelectric sensors. The DigiPyro® family features a highly sensitive ADC input stage, which does not require further amplification. This allows for the lowest supply currents and is therefore ideal for energy efficient, battery operated applications. Selecting a digital sensor in a TO-can will significantly expedite your design process and lower the susceptibility to EMI. This is particularly important when you design a device with wireless communication features. Excelitas offers several digital solutions meeting various requirements.

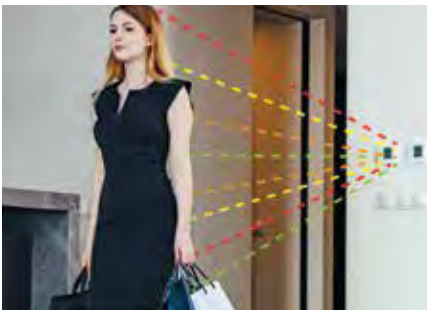

## DigiPyro

The simplest DigiPyro solution consists of a high-resolution ADC within the component housing. The data is transferred digitally through the proprietary direct link interface to the host system. In addition, an internal temperature reference channel is implemented in order to monitor component temperature changes. Excelitas offers one-channel (PYx x7xx series) and two-channel (PYx x8xx) solutions. While one-channel is optimal for dual-element sensors, two-channels allow for differential signal analysis with four-channel detectors.

Typically, a digital band-pass filter is applied on the host system's analysis code prior to the search for user defined motion criteria.

### Direct Link Interface

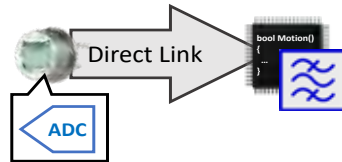

The Direct Link Interface was specially designed for pyroelectric sensors. This one wire interface does not require any external clock since communication speed is controlled by the host system. Either the host system or the sensor can initiate the transmission of data packages. Only one pin is required allowing for extremely compact metal can designs. Since the component drains very little current through the internal ASIC, the disturbance to the heat sensitive pyro-electric material is minimized.

### Low-Power DigiPyro

In addition to the digitization stage, the Low Power DigiPyro Series (PYx x5xx and PYx x9xx) also contain an internal band-pass filter as well as a motion detection unit. After power-up, the host system configures the sensor and waits for an interrupt signal by the sensor.

The host system can adjust, via band-pass properties, the threshold which the amplitude has to cross, define the number of threshold crossings, the window time and a dead time to suppress immediate re-triggering.

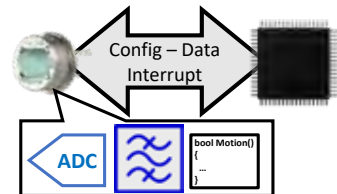

While the PYx x5xx feature lowest possible power consumption with one PIR channel, PYx x9xx Series have two separately configurable PIR motion detection channels. This allows for differential signal analysis and improved signal-to-noise performance.

The optimal choice of parameters depends on the application and the selected lens. To determine those, the raw data can be accessed and analyzed.

The low power DigiPyro series are the optimal choice for battery-operated systems since the host system can be put to sleep while the sensor is continuously monitoring motion of people.

**Distributor**

nordics@amstechnologies.com  
aspect.amstechnologies.com

**amSTECHNOLOGIES**  
where technologies meet solutions

Contact us